

Serie LK



LK-LKN



LK36 – LK40 – LK45

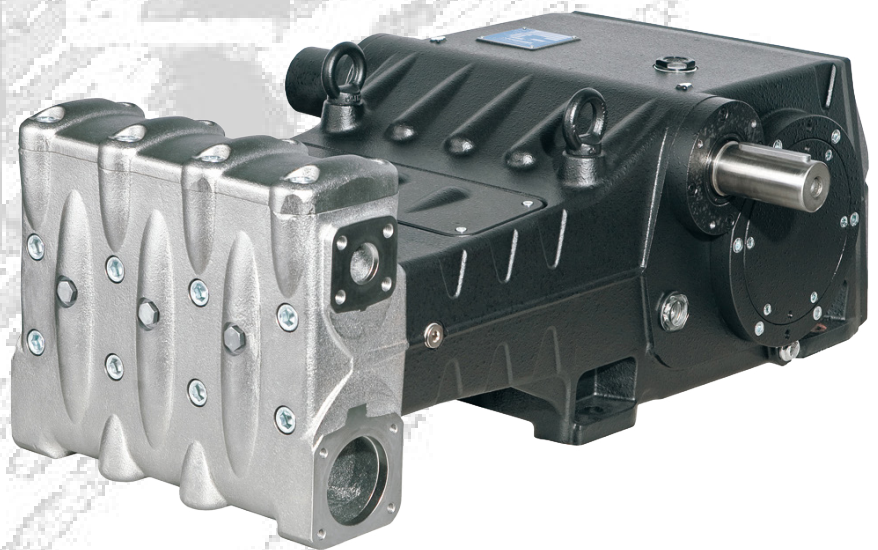

LK50 – LK55 – LK60



Manuale di riparazione
Repair Manual
Manuel de réparation
Reparaturanleitung
Manual de reparación
Manual de reparação

Sommario

1	INTRODUZIONE.....	3
1.1	DESCRIZIONE SIMBOLI	3
2	NORME DI RIPARAZIONE	3
2.1	RIPARAZIONE DELLA PARTE MECCANICA	3
2.1.1	<i>Smontaggio della parte meccanica</i>	3
2.1.2	<i>Montaggio parte meccanica</i>	11
2.1.3	<i>Classi di maggiorazione previste</i>	21
2.2	RIPARAZIONE DELLA PARTE IDRAULICA	21
2.2.1	<i>Smontaggio della testata - gruppi valvole</i>	21
2.2.2	<i>Montaggio della testata - gruppi valvole</i>	23
2.2.3	<i>Smontaggio del gruppo pistone - supporti - tenute</i>	27
2.2.4	<i>Montaggio del gruppo pistone - supporti - tenute</i>	29
2.2.5	<i>Recupero testate</i>	32
3	TARATURE SERRAGGIO VITI	33
4	ATTREZZI PER LA RIPARAZIONE	34
5	VERSIONI SPECIALI	34
6	SOSTITUZIONE DELLA BOCCOLA DI PIEDE BIELLA	35

1 INTRODUZIONE

Questo manuale descrive le istruzioni per la riparazione delle pompe famiglia LK e deve essere attentamente letto e compreso prima di effettuare ed eseguire qualsiasi intervento sulla pompa.

Dal corretto uso e dalle adeguate manutenzione dipende il regolare funzionamento e durata della pompa.

Interpump Group declina ogni responsabilità per danni causati da negligenza e mancata osservazione delle norme descritte in questo manuale.

1.1 DESCRIZIONE SIMBOLI

Leggere attentamente quanto riportato in questo manuale prima di ogni operazione.



Segnale di Avvertenza



Leggere attentamente quanto riportato in questo manuale prima di ogni operazione.



Segnale di Pericolo

Munirsi di occhiali protettivi.



Segnale di Pericolo

Munirsi di guanti protettivi prima di ogni operazione.

2 NORME DI RIPARAZIONE



2.1 RIPARAZIONE DELLA PARTE MECCANICA

Le operazioni di riparazione della parte meccanica devono essere eseguite dopo aver rimosso l'olio dal carter.

Per togliere l'olio occorre rimuovere il tappo di carico olio pos. ①, Fig. 1 e successivamente il tappo di scarico pos. ②, Fig. 1.

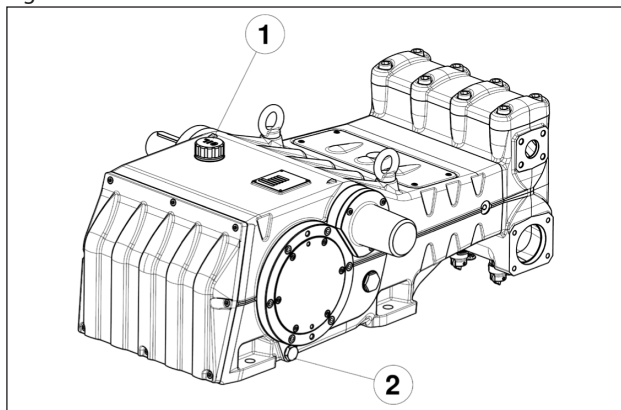

Fig. 1



L'olio esausto deve essere messo in un apposito recipiente e smaltito negli appositi centri. Non deve essere assolutamente disperso nell'ambiente.

2.1.1 Smontaggio della parte meccanica

La corretta sequenza è la seguente:

Svuotare completamente la pompa dall'olio, come indicato al par. 2.1.

Smontare gli alzavalvola dalla testata e la testata dal carter pompa come indicato nel par. 2.2.1 (da Fig. 103 a Fig. 105).

Rimuovere il coperchio di ispezione superiore e il coperchio di ispezione inferiore svitando le 4+4 viti di fissaggio come indicato nel par. 2.2.3 (Fig. 139 e Fig. 140).

Sfilare gli O-ring e sostituirli qualora fosse necessario.

Rimuovere i tre pistoni e i gruppi camicie-supporti guarnizione come indicato nel par. 2.2.3 (Fig. 138, Fig. 141 e Fig. 142).

Rimuovere i tre anelli distanziali paraspruzzi e i paraspruzzi come indicato nel par. 2.2.3 (Fig. 143 e Fig. 144).

Svitare i grani di bloccaggio M6 dei tre coperchi paraolio (pos. ①, Fig. 2).

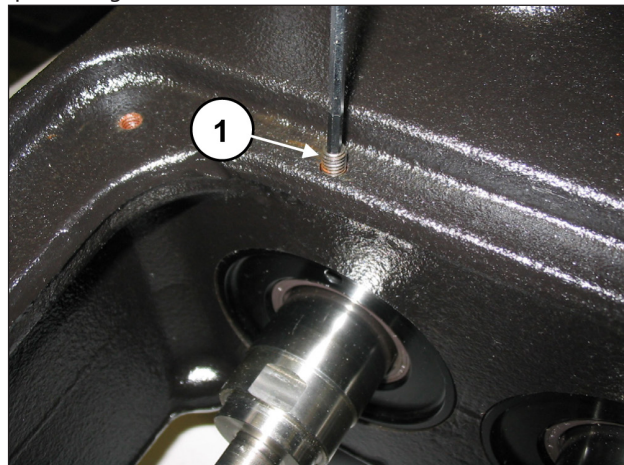

Fig. 2

Avvitare una barra filettata o una vite M6 con funzione di estrattore negli appositi fori sul coperchio paraolio (pos. ①, Fig. 3) ed estrarre i coperchi dal gruppo pompa (pos. ①, Fig. 4).

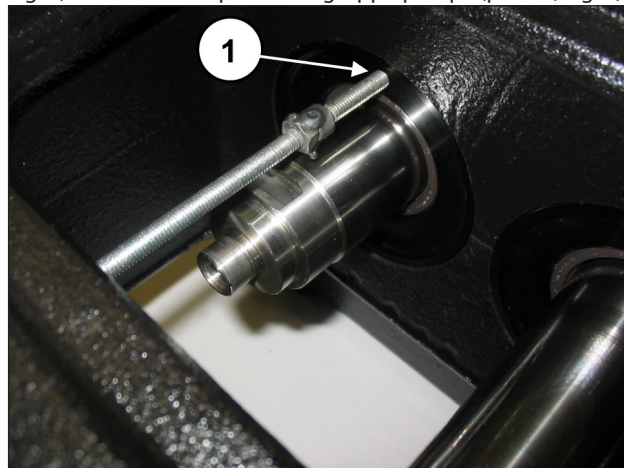

Fig. 3

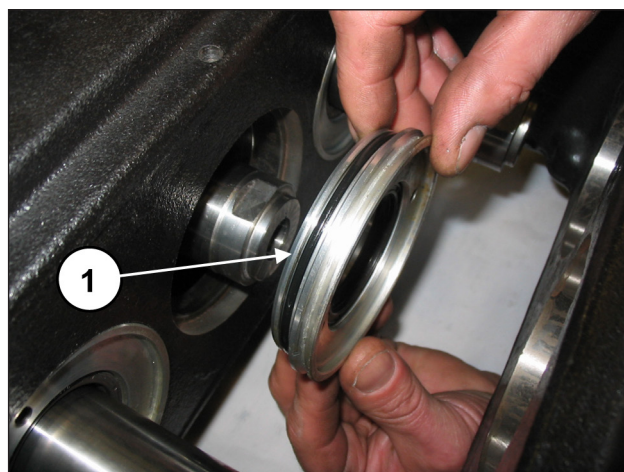

Fig. 4

Estrarre l'anello di tenuta radiale (pos. ①, Fig. 5) e l'O-ring esterno (pos. ①, Fig. 6).

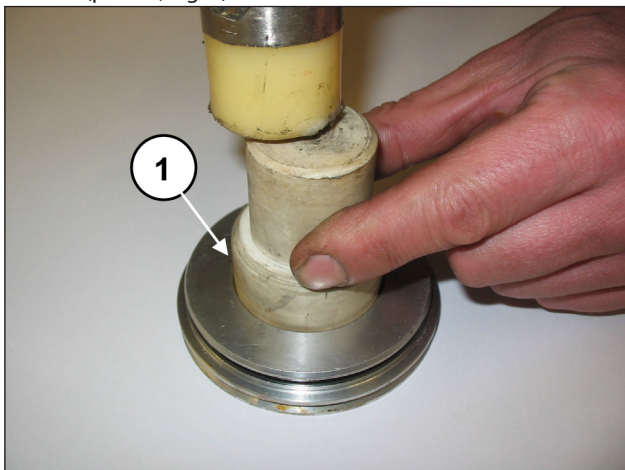

Fig. 5

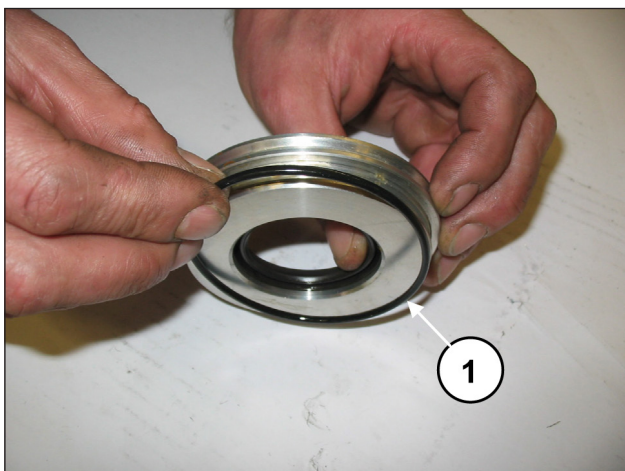

Fig. 6

Rimuovere la linguetta dall'albero PTO (pos. ①, Fig. 7).

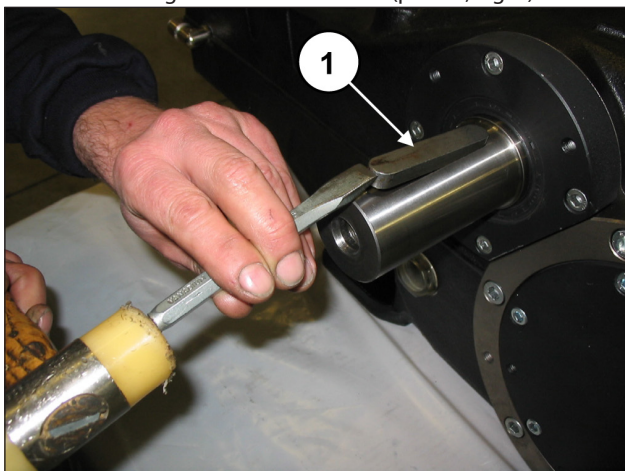

Fig. 7

Svitare le viti di fissaggio coperchio estremità albero (pos. ①, Fig. 8) e sfilare il coperchio dall'albero PTO.

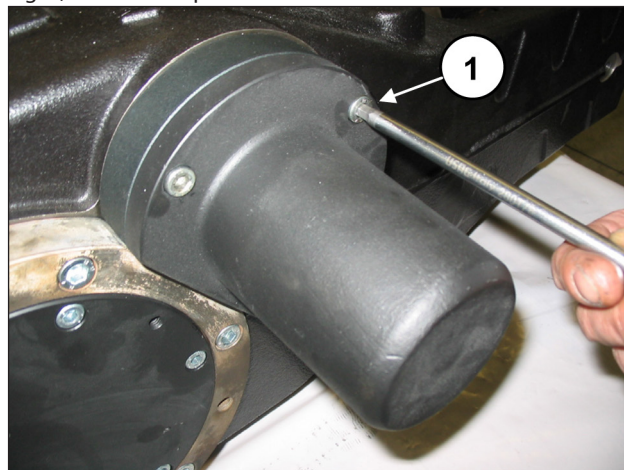

Fig. 8

Svitare le viti di fissaggio coperchio carter (pos. ①, Fig. 9) e rimuoverlo. Sfilare l'O-ring e sostituirlo qualora fosse necessario.

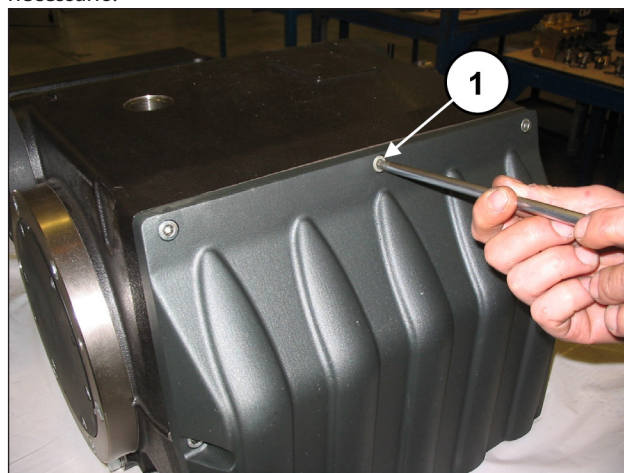

Fig. 9

Provvedere ora allo smontaggio dei due coperchi cuscinetto svitando le relative viti (pos. ①, Fig. 10).

Per agevolare lo smontaggio utilizzare n. 2 grani o viti M8 (pos. ①, Fig. 11) con la funzione di estrattori.

Sfilare l'O-ring e sostituirlo qualora fosse necessario.

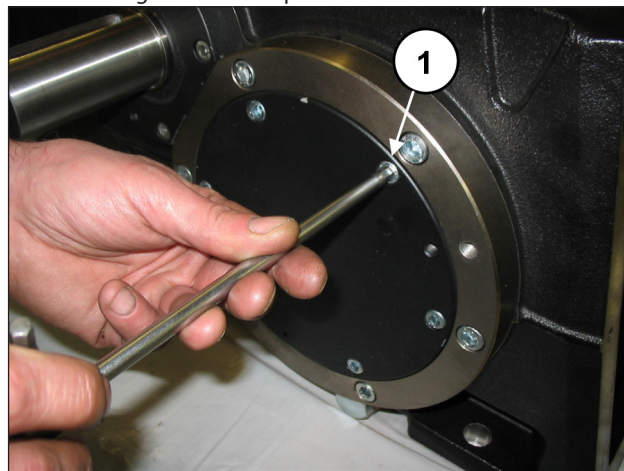

Fig. 10

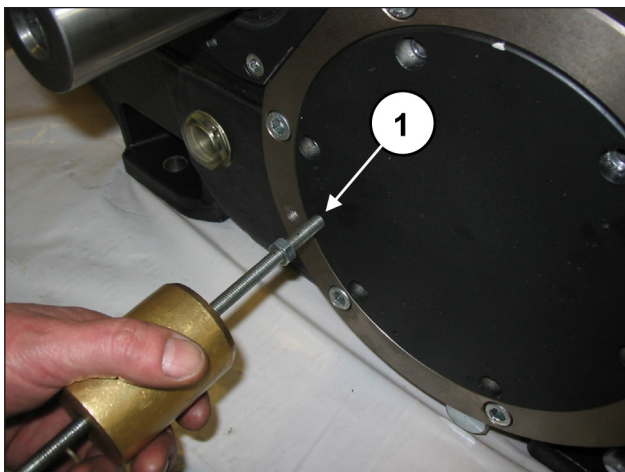

Fig. 11

Inserire uno spessore sotto al fusto della biella centrale per bloccare la rotazione dell'albero a gomiti (pos. ①, Fig. 12).

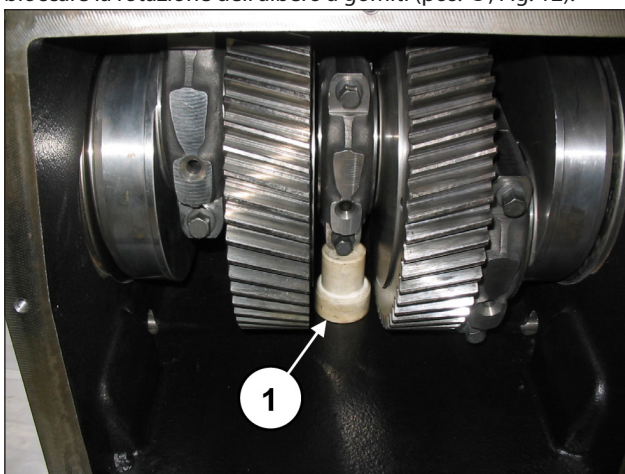

Fig. 12

Svitare ed estrarre le viti di fissaggio flangia bloccaggio bussola, da entrambi i lati (pos. ①, Fig. 13).

Le flangie bloccaggio bussola devono essere lasciate in sede (pos. ①, Fig. 14).

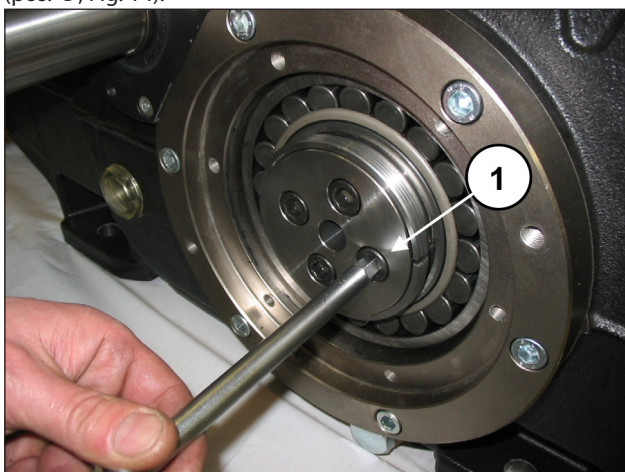

Fig. 13

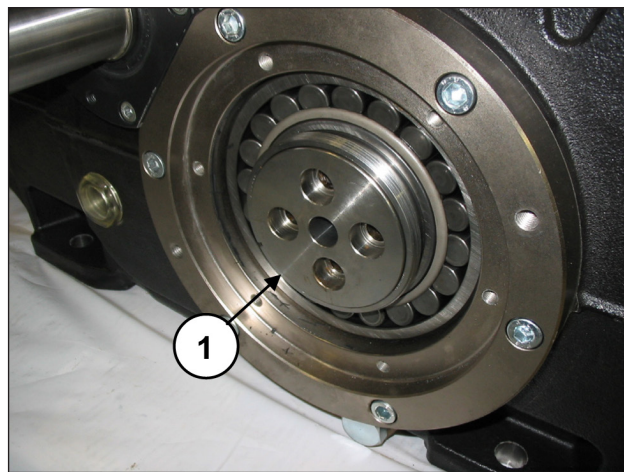

Fig. 14

Su di un lato avvitare una ghiera tipo SKF KM20 sulla bussola di pressione (pos. ①, Fig. 15), quindi sbloccare la bussola mediante massa battente (pos. ①, Fig. 16), senza estrarla. Ripetere l'operazione dal lato opposto.

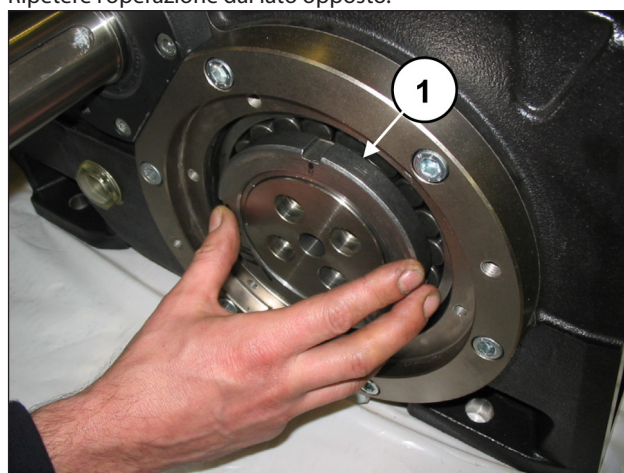

Fig. 15

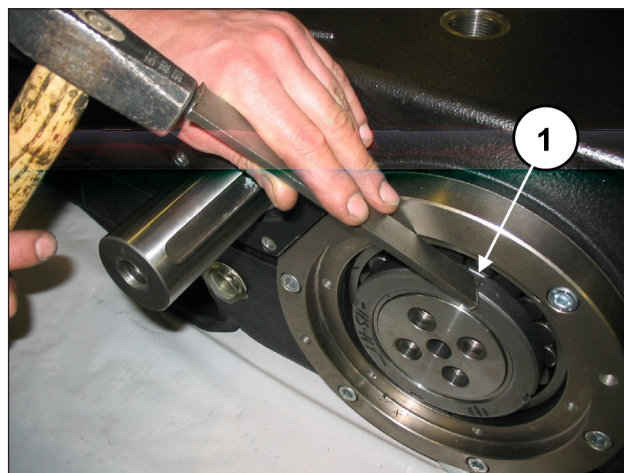

Fig. 16

Togliere lo spessore sotto al fusto della biella centrale.

Svitare le viti di biella (pos. ①, Fig. 17).

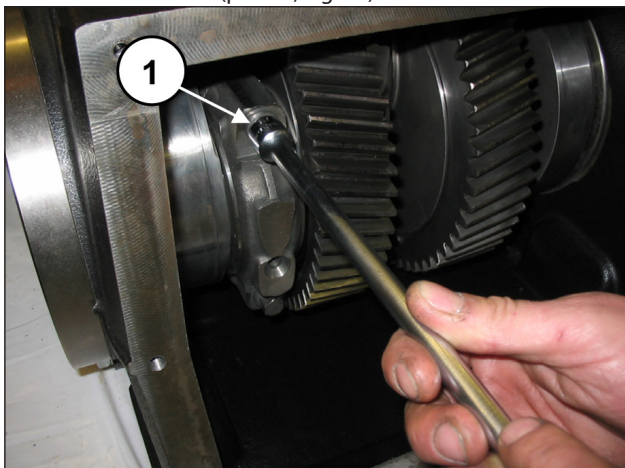

Fig. 17

Smontare i cappelli di biella con i semicuscinetti avendo particolare cura, durante lo smontaggio, dell'ordine in cui vengono smontati.



I cappelli di biella e le relative semibielle devono essere rimontati esattamente nello stesso ordine e accoppiamento in cui sono stati smontati.

Per evitare possibili errori cappelli e semibielle sono stati numerati su un lato (pos. ①, Fig. 18).

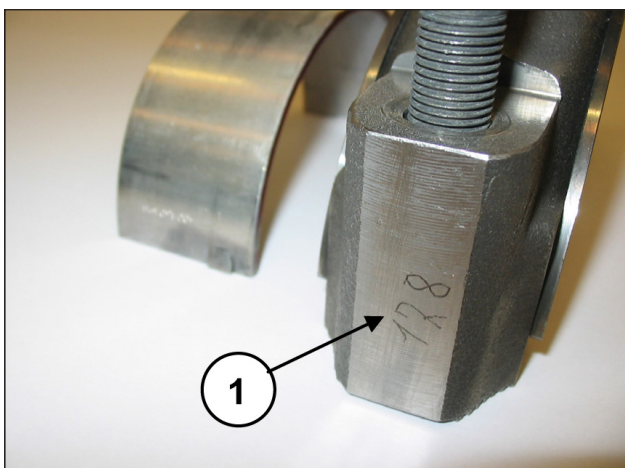
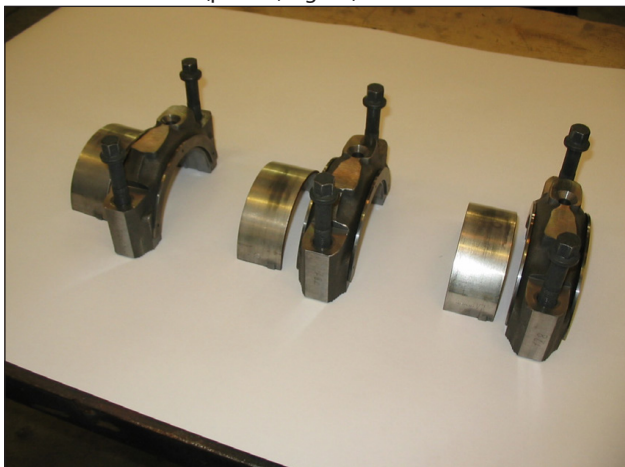

Fig. 18

Fare avanzare il più possibile le tre semibielle nella direzione della testata.

Sfilare i tre semicuscinetti superiori delle semibielle (pos. ①, Fig. 19).

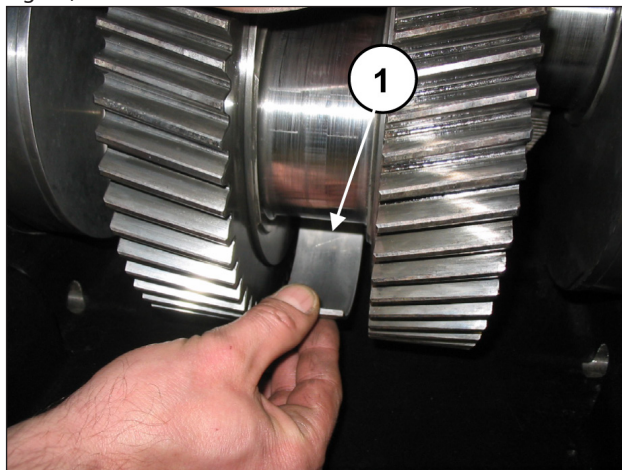

Fig. 19

Togliere entrambe le bussole di pressione (pos. ①, Fig. 20).

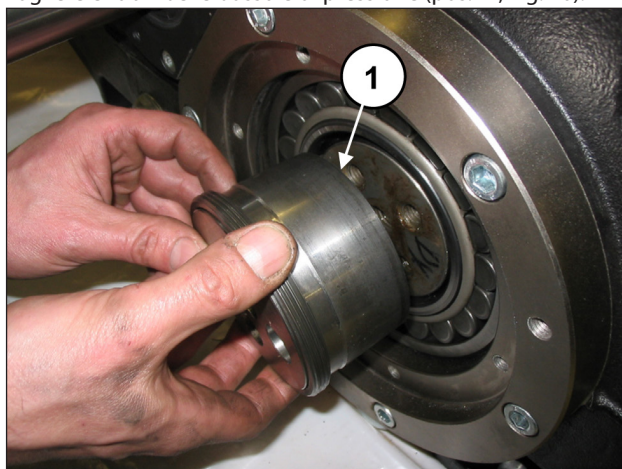

Fig. 20

Separare la flangia bloccaggio bussola dalla bussola di pressione (pos. ①, Fig. 21).

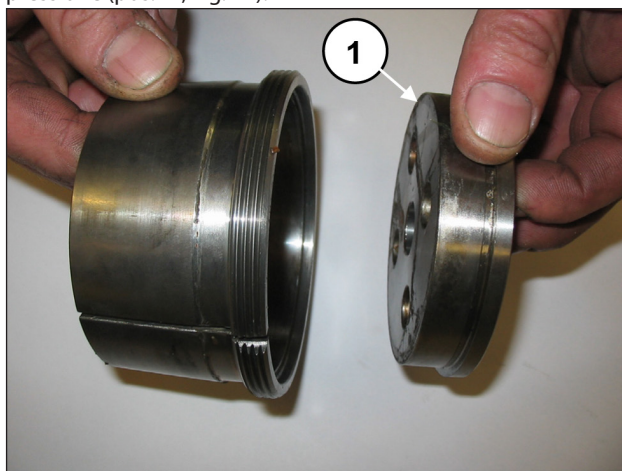

Fig. 21

Svitare le viti dei due coperchi portacuscinetto (pos. ①, Fig. 22).

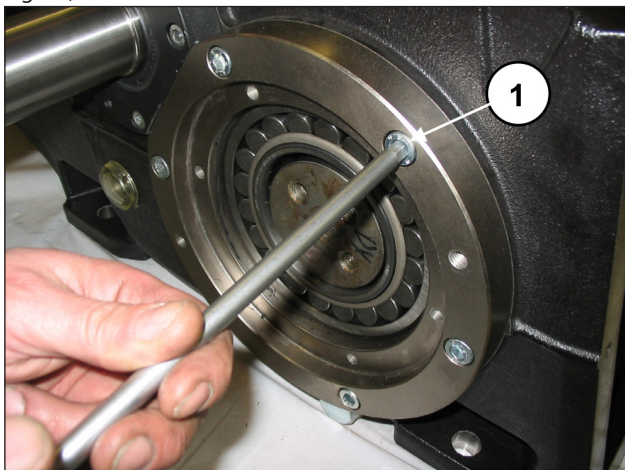

Fig. 22

Applicare un perno filettato M16 ad un'estremità dell'albero a gomiti (pos. ①, Fig. 23) e, tenendolo sollevato, estrarre il coperchio portacuscinetto completo di cuscinetto e O-ring (pos. ①, Fig. 24). Per agevolare lo smontaggio utilizzare n. 2 grani o viti M10 (pos. ②, Fig. 23) con la funzione di estrattori. Ripetere l'operazione dal lato opposto.

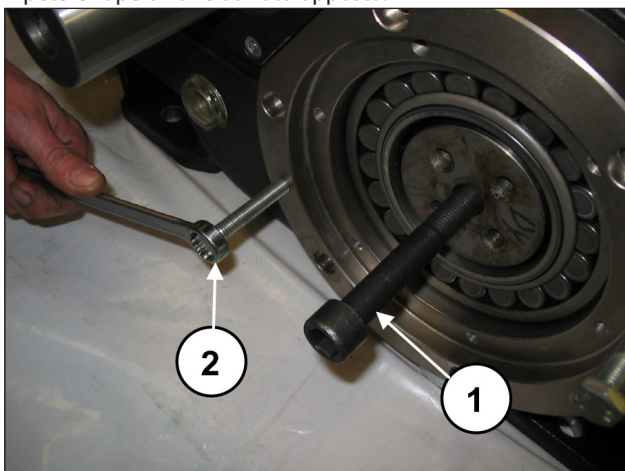

Fig. 23

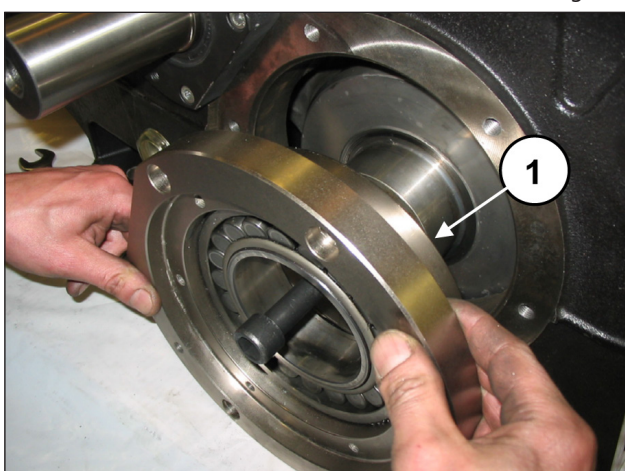

Fig. 24

Appoggiare l'albero a gomiti sul fondo del carter.

Separare il coperchio portacuscinetto dal cuscinetto mediante l'utilizzo di una massa battente (pos. ①, Fig. 25).

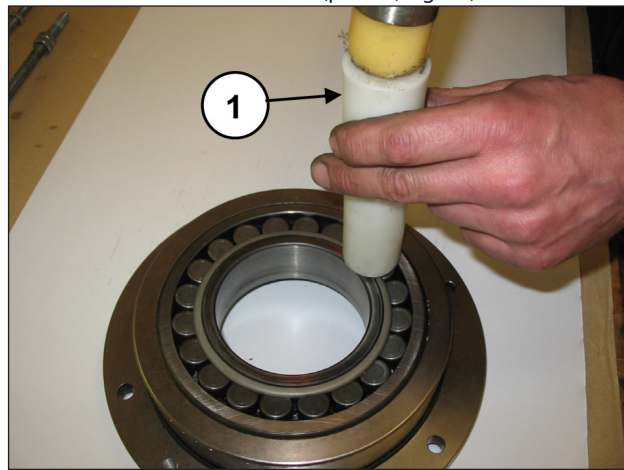

Fig. 25

Svitare le viti di fissaggio coperchio cuscinetto PTO destro e sinistro (pos. ①, Fig. 26) e sfilare i due coperchi dall'albero PTO. Per agevolare lo smontaggio utilizzare n. 3 grani o viti M8 (pos. ①, Fig. 27) con la funzione di estrattori.

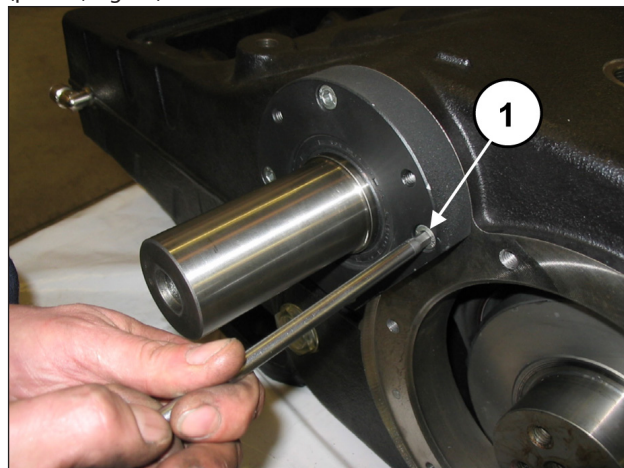

Fig. 26

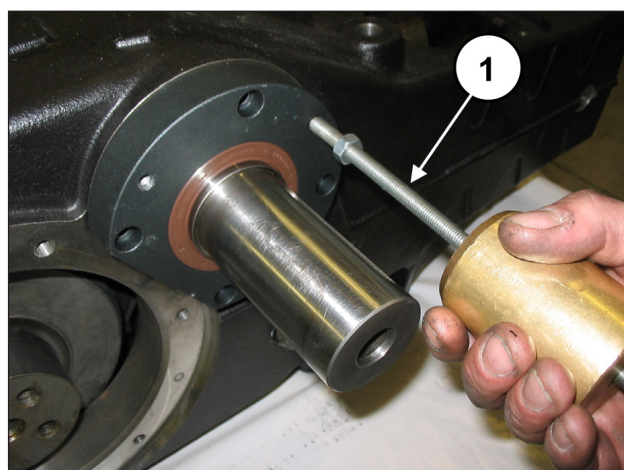

Fig. 27

Estrarre l'anello di tenuta radiale (pos. ①, Fig. 28), l'O-ring esterno (pos. ①, Fig. 29) e l'O-ring del foro di lubrificazione (pos. ①, Fig. 30).

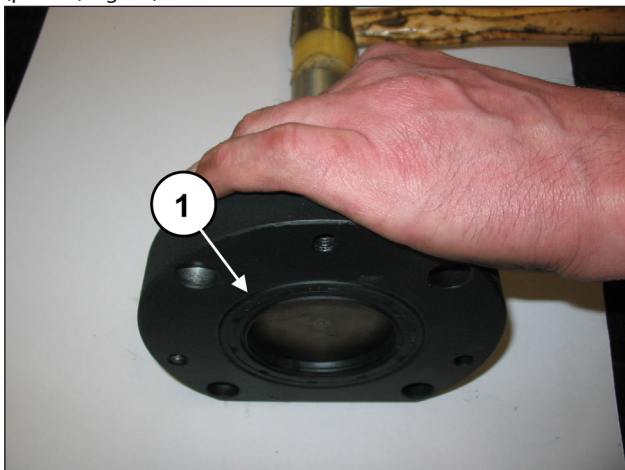

Fig. 28

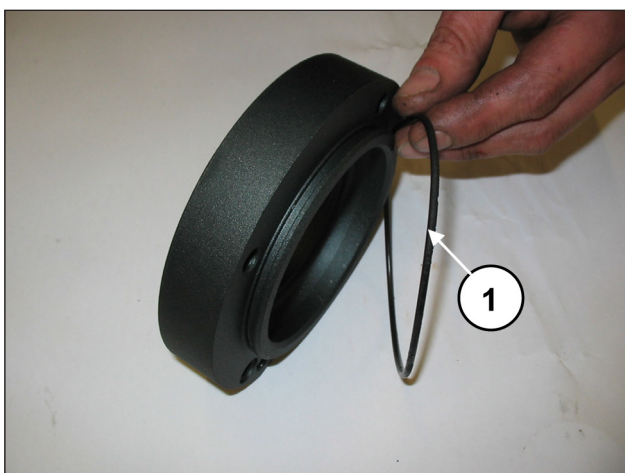

Fig. 29

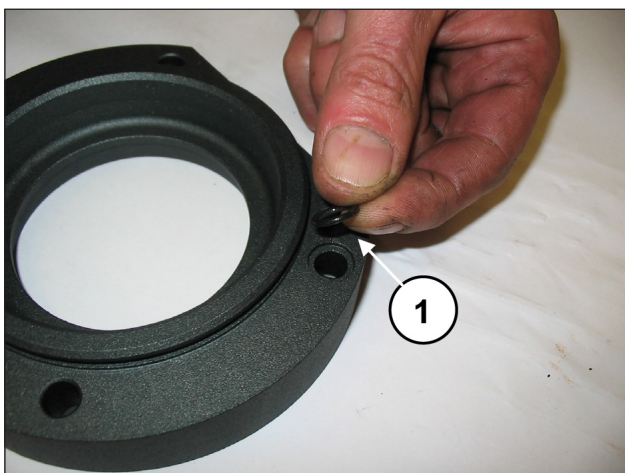

Fig. 30

Far indietreggiare il più possibile le tre bielle (portarle a contatto con l'albero a gomiti).

Mediante l'utilizzo di una massa battente (pos. ①, Fig. 31) estrarre l'albero PTO da uno qualsiasi dei due lati (pos. ①, Fig. 32).

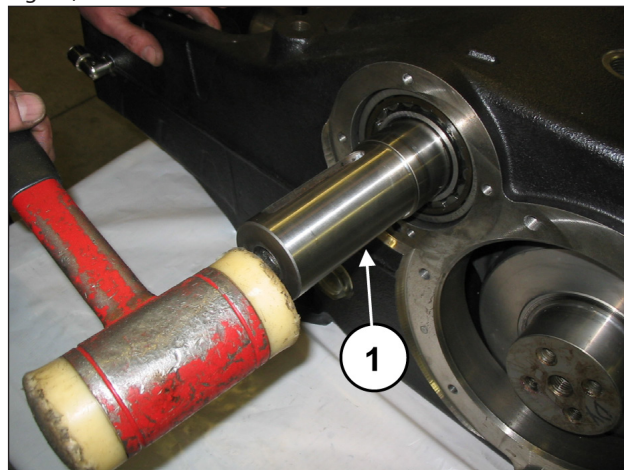

Fig. 31

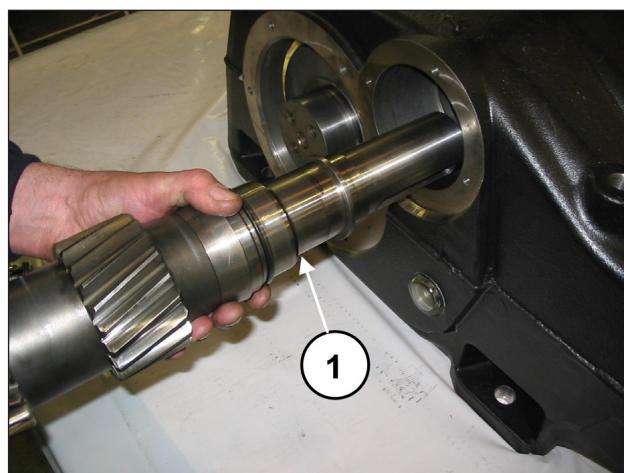

Fig. 32

Sfilare gli anelli interni dei cuscinetti dall'albero PTO (pos. ①, Fig. 33) e i due distanziali cuscinetto interno (pos. ②, Fig. 33).

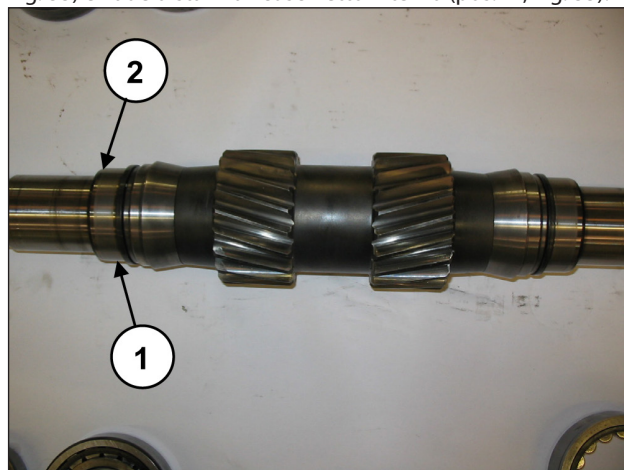

Fig. 33



Gli anelli interni ed esterni dei cuscinetti devono essere rimontati esattamente nello stesso ordine e accoppiamento in cui sono stati smontati.

Mediante l'utilizzo di una barra sufficientemente lunga (pos. ①, Fig. 34) e di una massa battente estrarre dal carter pompa gli anelli dei cuscinetti (pos. ①, Fig. 35), il distanziale cuscinetto esterno (pos. ①, Fig. 36) e la bussola di lubrificazione cuscinetti (pos. ①, Fig. 37).

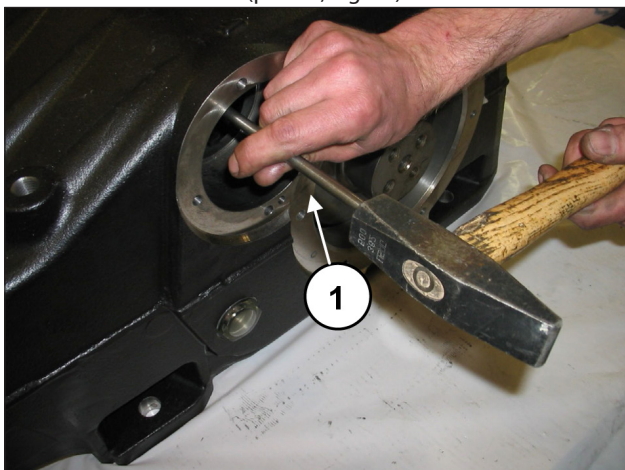

Fig. 34

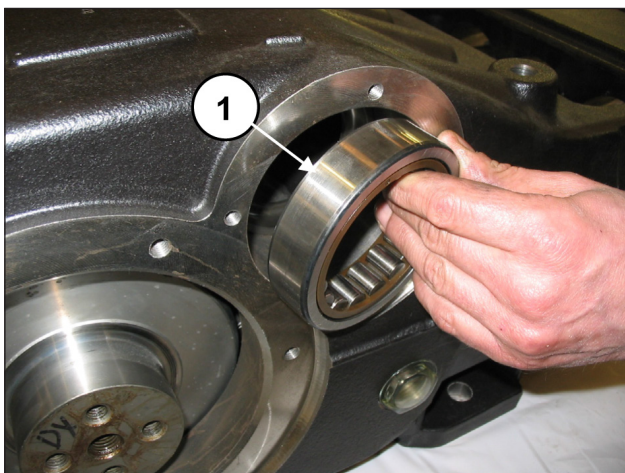

Fig. 35

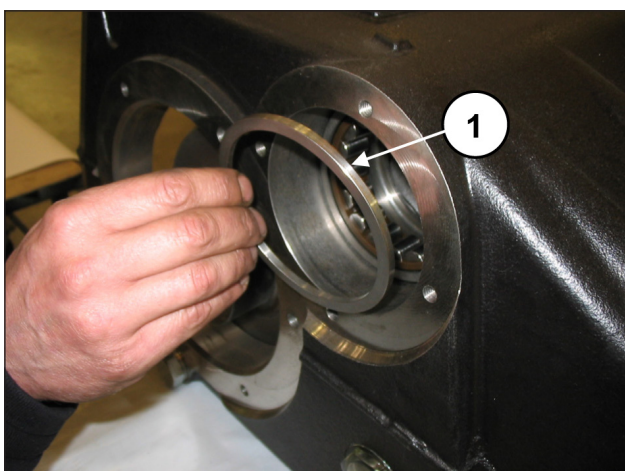

Fig. 36

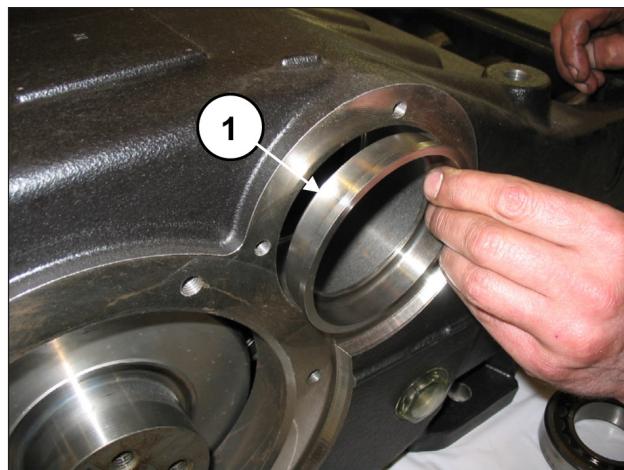

Fig. 37

Fare avanzare le semibielle nella direzione della parte idraulica e bloccarle mediante l'utilizzo dell'apposito attrezzo (cod. 27566200) (pos. ①, Fig. 38).

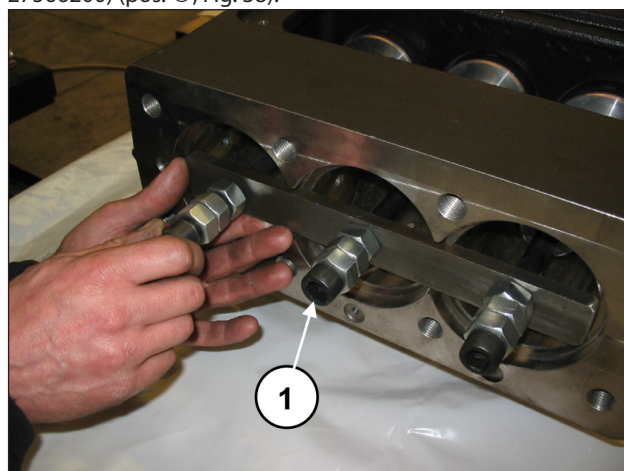

Fig. 38

Sfilare l'albero a gomiti dalla parte posteriore del carter (pos. ① pos. ①, Fig. 39).

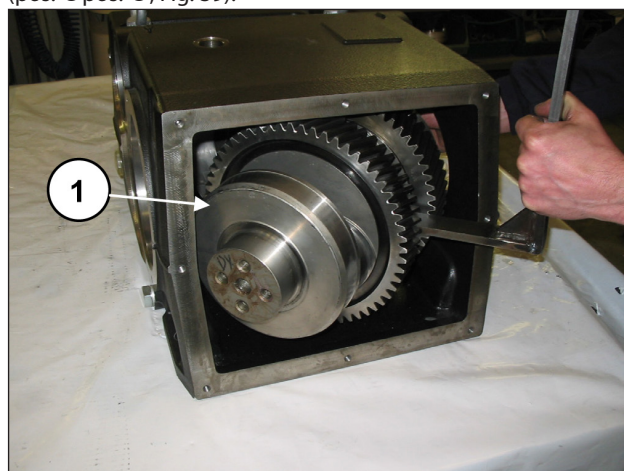

Fig. 39

Procedere a svitare le viti dell'attrezzo cod. 27566200 per sbloccare le bielle (pos. ①, Fig. 40) e successivamente estrarre i gruppi biella-guida pistone dall'apertura posteriore del carter (pos. ①, Fig. 41).

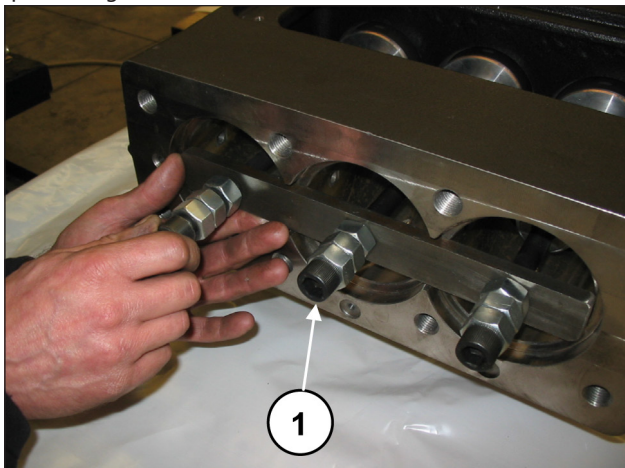

Fig. 40

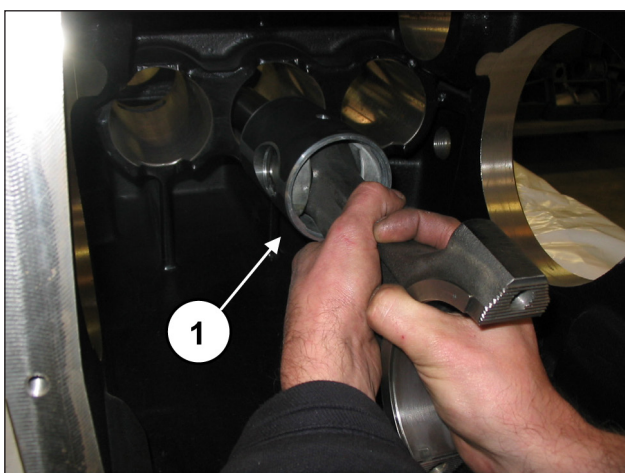

Fig. 41

Accoppiare le semibielle ai cappelli precedentemente smontati facendo riferimento alla numerazione (pos. ①, Fig. 42).

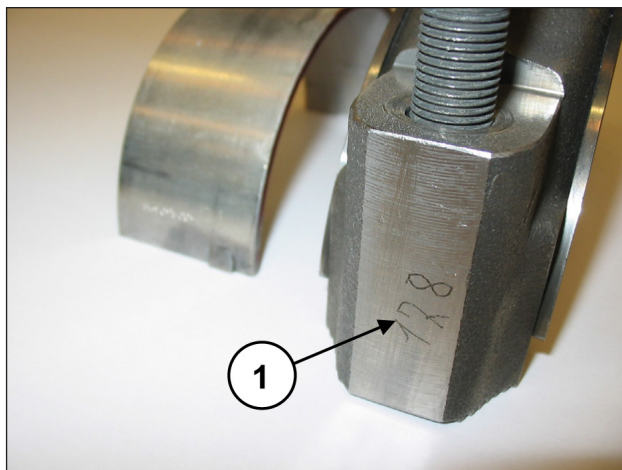
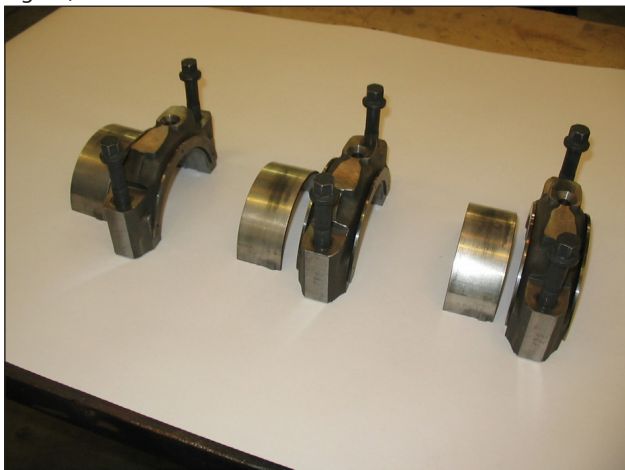

Fig. 42

Rimuovere i due anelli seeger di bloccaggio spinotto utilizzando un apposito attrezzo (pos. ①, Fig. 43).

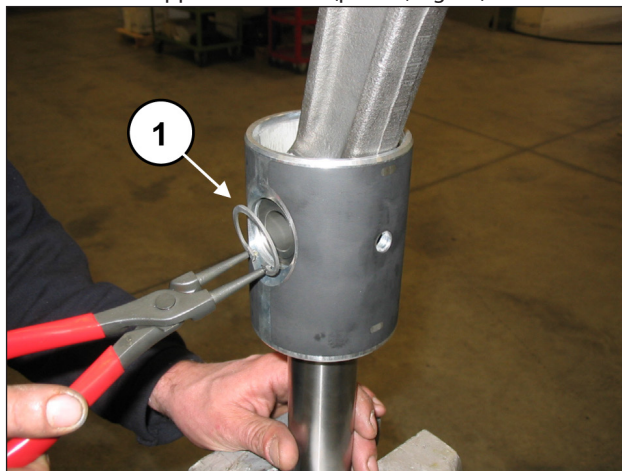

Fig. 43

Sfilare lo spinotto (pos. ①, Fig. 44) e provvedere all'estrazione della biella (pos. ①, Fig. 45).

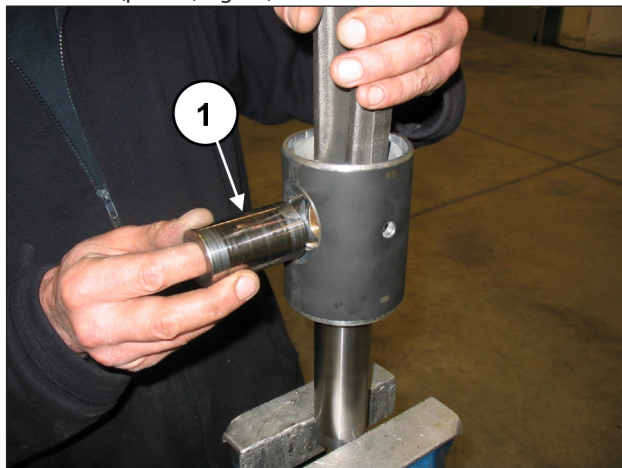

Fig. 44

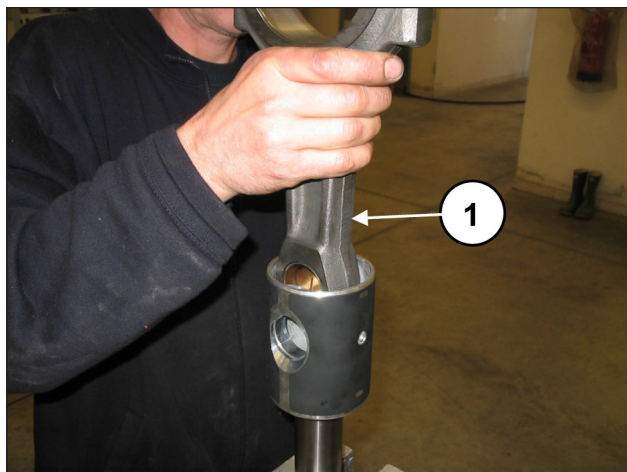

Fig. 45

Per separare lo stelo dal guida pistone occorre svitare le viti a testa cilindrica M6 mediante apposita chiave (pos. ①, Fig. 46).

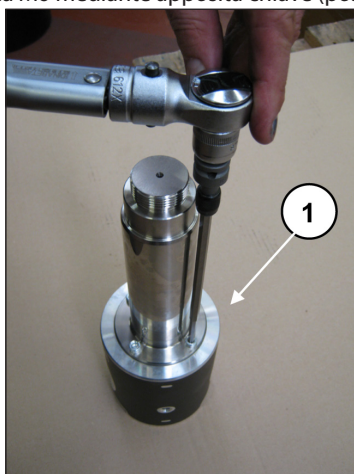

Fig. 46

Completare lo smontaggio della parte meccanica smontando le spie livello olio e i golfari.

2.1.2 Montaggio parte meccanica

Procedere al montaggio seguendo il procedimento inverso indicato al par. 2.1.1.

La corretta sequenza è la seguente:

Montare le due spie livello olio, i due tappi scarico olio e il raccordo con attacco rapido a 90° (pos. ①, ② e ③ Fig. 47).

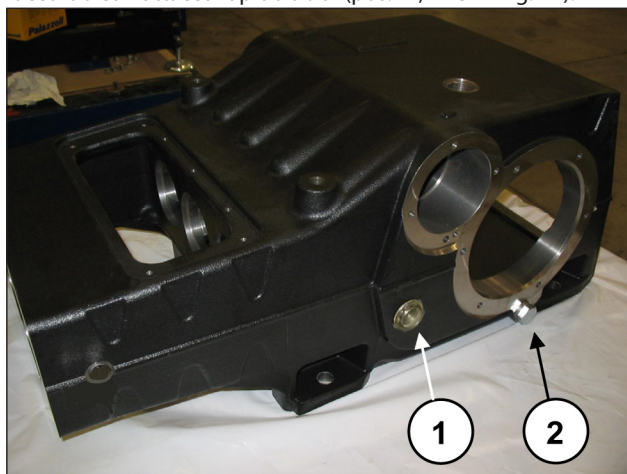

Fig. 47

Assemblare lo stelo al guida pistone.

Inserire lo stelo guida pistone nell'apposita sede sul guida pistone (pos. ①, Fig. 48) e fissarlo a quest'ultimo mediante le 4 viti a testa cilindrica M6x20 (pos. ①, Fig. 49).



Fig. 48

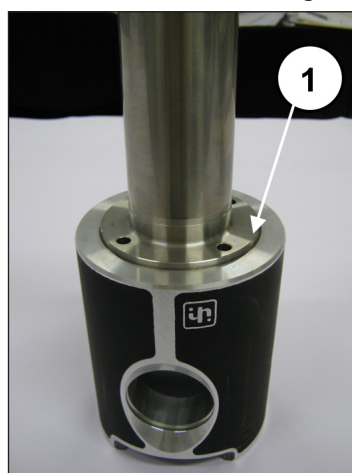

Fig. 49

Bloccare il guida pistone in morsa con l'ausilio di apposito attrezzo e procedere alla taratura delle viti con chiave dinamometrica (pos. ①, Fig. 50) come indicato nel capitolo 3.

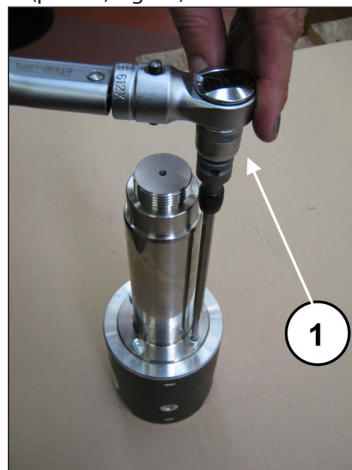

Fig. 50

Inserire la biella nel guida pistone (pos. ①, Fig. 45) e successivamente inserire lo spinotto (pos. ①, Fig. 44). Applicare i due seeger di spallamento con l'apposito attrezzo (pos. ①, Fig. 43).



Il corretto montaggio è garantito se piede biella, guida pistone e spinotto ruotano liberamente.

Separare i cappelli dalle semibielle; il corretto accoppiamento sarà garantito dalla numerazione posta su un lato (pos. ①, Fig. 42).

Dopo aver verificato la perfetta pulizia del carter inserire il gruppo semibiella-guida pistone all'interno delle canne del carter (pos. ①, Fig. 41).



L'inserimento del gruppo semibiella-guida pistone nel carter deve essere fatto orientando le semibielle con la numerazione visibile dall'alto.

Bloccare i tre gruppi utilizzando l'apposito attrezzo cod. 27566200 (pos. ①, Fig. 40).

Inserire l'albero a gomiti attraverso l'apertura posteriore del carter ed appoggiarlo sul fondo.



L'inserimento dell'albero a gomiti nel carter deve essere effettuato in modo che la dentatura delle corone risulti orientata come in Fig. 51.

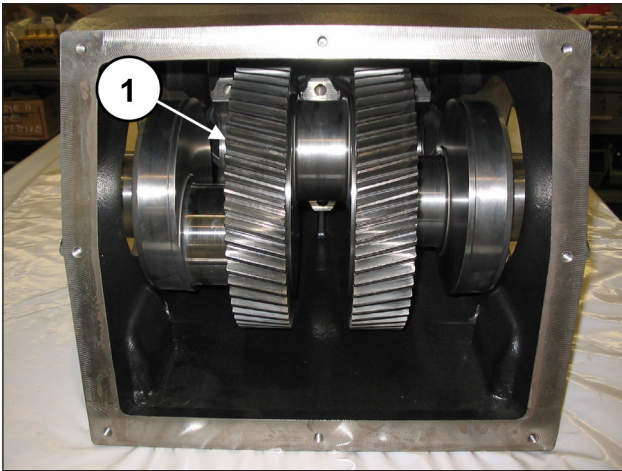

Fig. 51

Premontare l'albero PTO: inserire sull'albero PTO i 2 anelli interni dei cuscinetti (uno per lato) (pos. ①, Fig. 52).

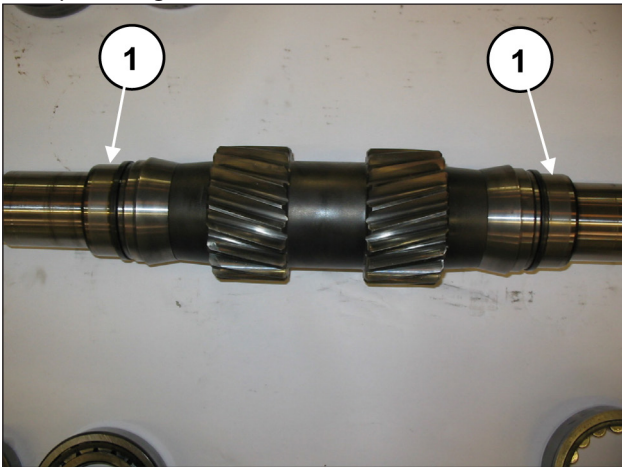

Fig. 52



Gli anelli interni ed esterni dei cuscinetti devono essere rimontati esattamente nello stesso ordine e accoppiamento in cui sono stati smontati.

Da un lato del carter inserire la bussola di lubrificazione cuscinetti (pos. ①, Fig. 53) e un anello esterno del cuscinetto (pos. ①, Fig. 54) mediante l'utilizzo di un tampone e massa battente.

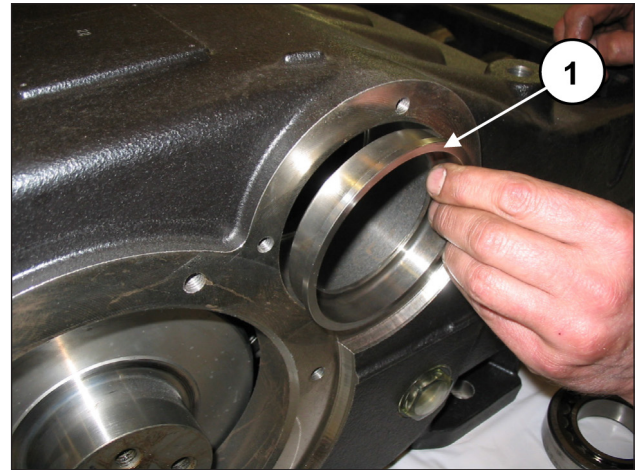

Fig. 53

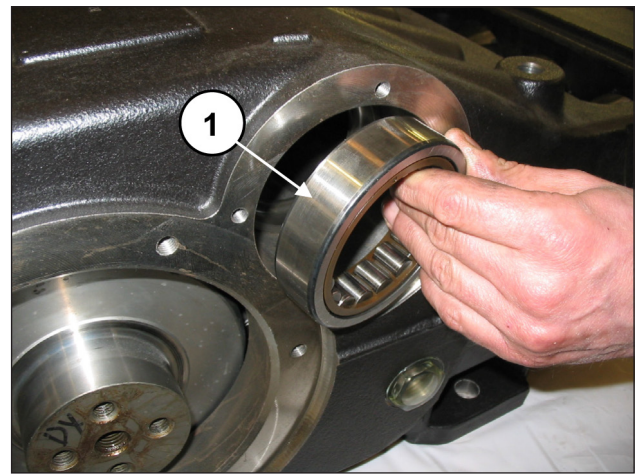

Fig. 54

Rimuovere l'attrezzo per il bloccaggio delle bielle cod. 27566200 (pos. ①, Fig. 40) e far scorrere le bielle all'indietro fino ad arrivare a contatto con l'albero a gomiti. Inserire l'albero PTO premontato all'interno del carter (pos. ①, Fig. 55) inserendolo dalla parte opposta a quella in cui sono stati premontati l'anello esterno del cuscinetto e la bussola di lubrificazione cuscinetti.



L'inserimento dell'albero PTO nel carter deve essere effettuato in modo che la dentatura risulti orientata come in Fig. 55.

Per agevolare l'inserimento completo dell'albero PTO all'interno del cuscinetto utilizzare una vite M16 da applicare all'estremità dell'albero da inserire, allo scopo di mantenere sollevato l'albero stesso (pos. ①, Fig. 56).

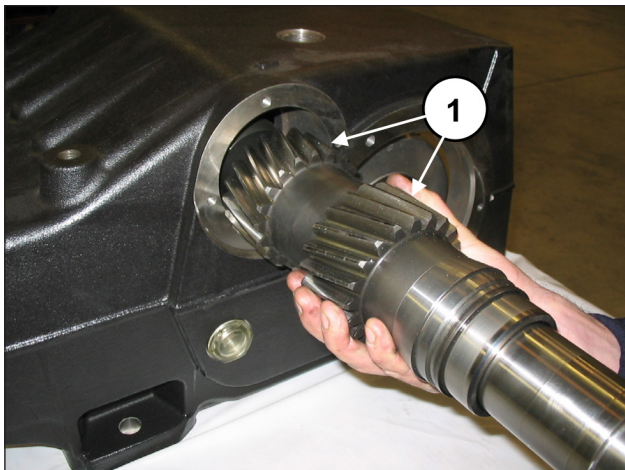

Fig. 55

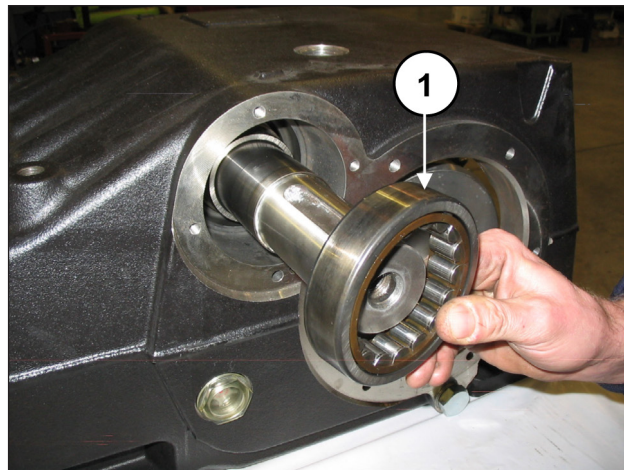

Fig. 58

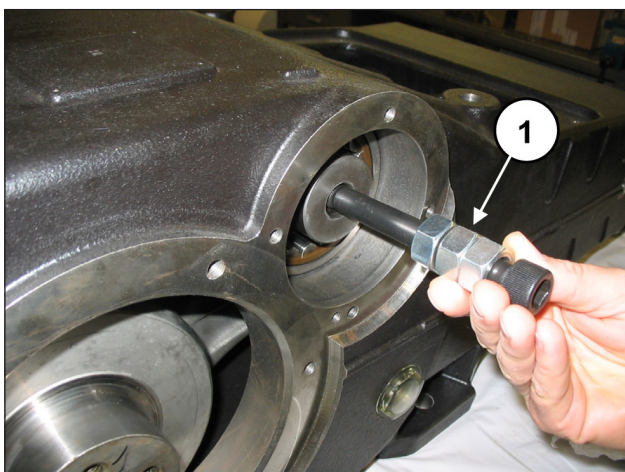

Fig. 56

Dal lato in cui si è inserito l'albero PTO procedere con l'inserimento della bussola di lubrificazione cuscinetti (pos. ①, Fig. 57) e di un anello esterno del cuscinetto (pos. ①, Fig. 58) mediante l'utilizzo di un tampone e massa battente.



Fig. 57

Da entrambi i lati inserire i distanziali cuscinetto interno (pos. ①, Fig. 59) ed esterno (pos. ①, Fig. 60).

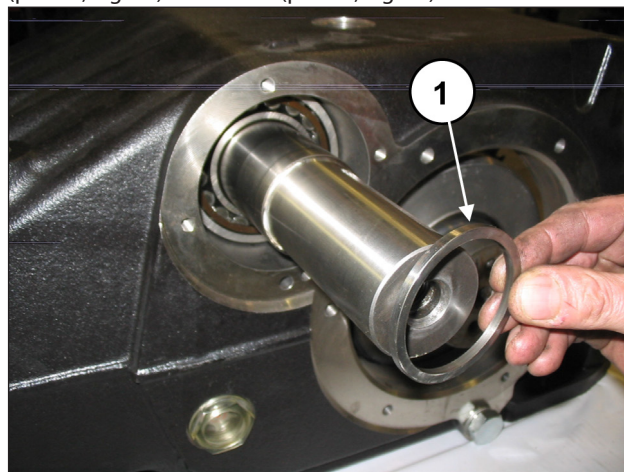

Fig. 59

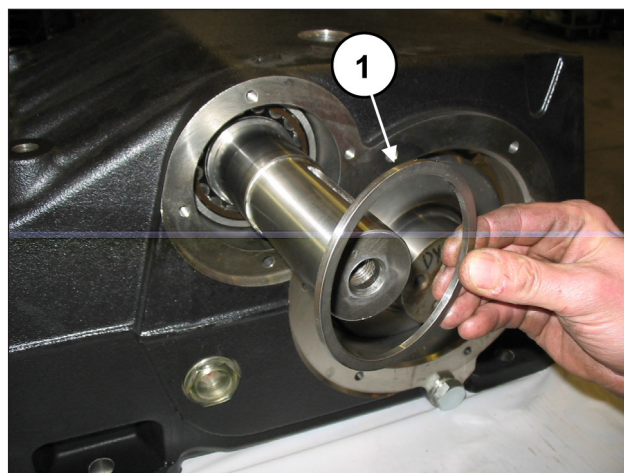

Fig. 60

Inserire l'anello interno (pos. ①, Fig. 61) e l'anello esterno (pos. ①, Fig. 62) di un cuscinetto da un solo lato della pompa.

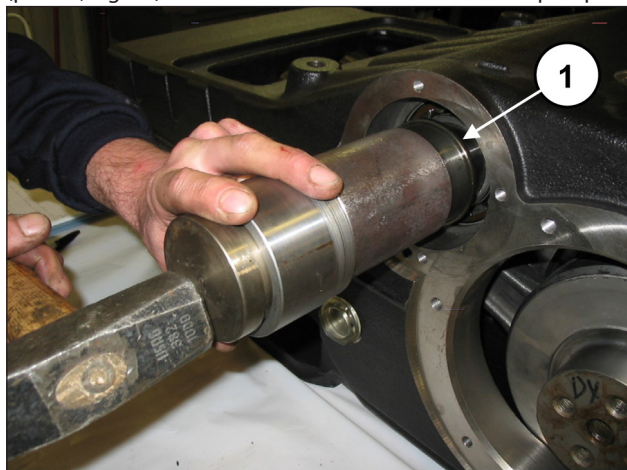

Fig. 61



Fig. 62

Premontare i coperchi cuscinetto PTO destro e sinistro: Inserire l'anello di tenuta radiale all'interno del coperchio cuscinetto PTO mediante l'utilizzo dell'attrezzo cod. 27539500 (pos. ①, Fig. 63).

Prima di procedere con il montaggio dell'anello di tenuta radiale verificare le condizioni del labbro di tenuta. Se si rende necessaria la sostituzione posizionare il nuovo anello come indicato in Fig. 64.



Qualora l'albero PTO presentasse una usura diametrale in corrispondenza del labbro di tenuta, per evitare l'operazione di rettifica si può posizionare l'anello in seconda battuta come indicato nella Fig. 64.

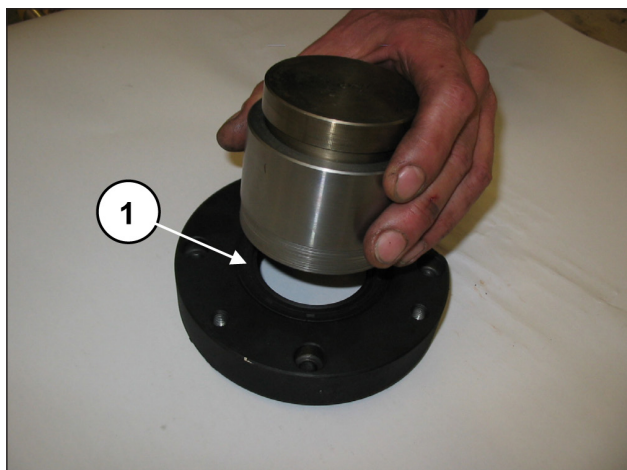

Fig. 63

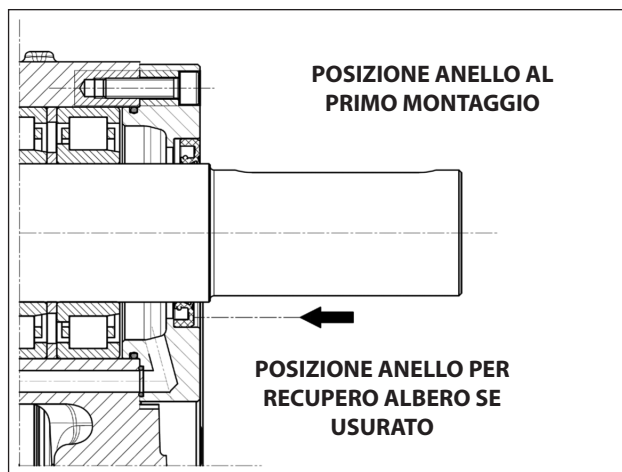

Fig. 64

Applicare ai coperchi cuscinetto PTO l'O-ring esterno (pos. ①, Fig. 65) e l'O-ring del foro di lubrificazione (pos. ①, Fig. 66).

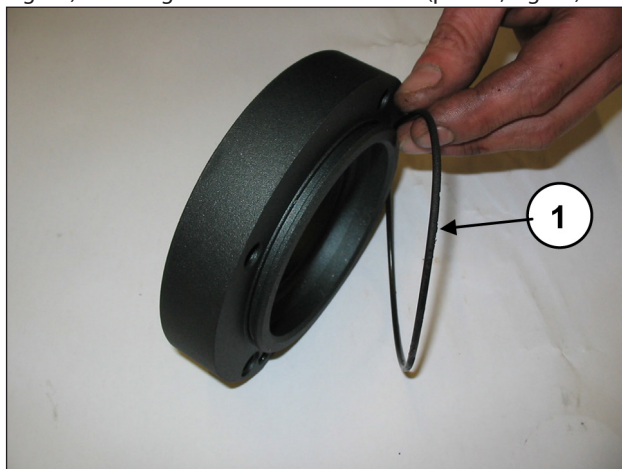

Fig. 65

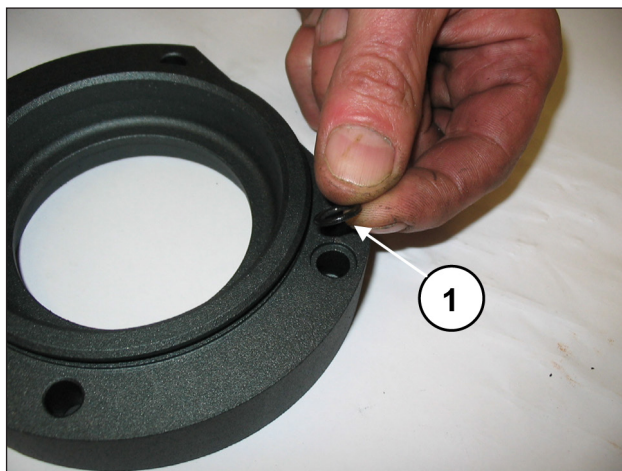

Fig. 66

Montare un primo coperchio cuscinetto PTO (destro o sinistro) al carter pompa (pos. ①, Fig. 67) e fissarlo mediante 4 viti M8x30 (pos. ①, Fig. 68).



Prestare attenzione al senso di montaggio del coperchio. Il foro di lubrificazione del coperchio deve trovarsi in corrispondenza del foro sul carter.

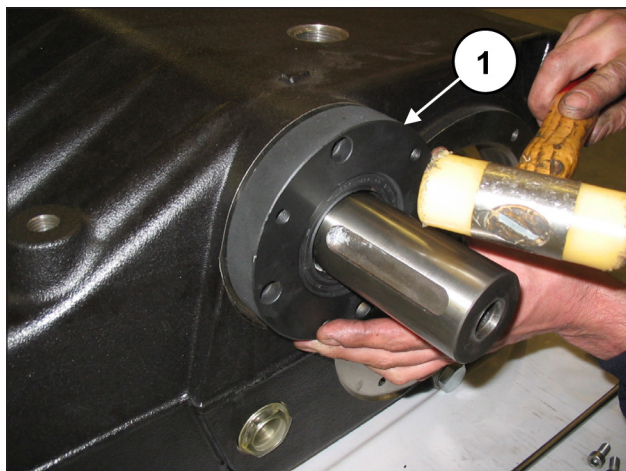

Fig. 67

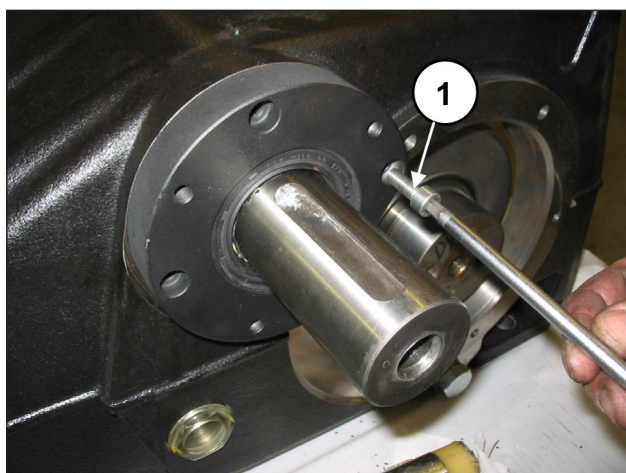

Fig. 68

Ripetere le operazioni dal lato opposto:

Inserire l'anello interno (pos. ①, Fig. 61) e l'anello esterno (pos. ①, Fig. 62) dell'ultimo cuscinetto.

Montare il coperchio cuscinetto PTO mancante sul carter pompa (pos. ①, Fig. 67) e fissarlo mediante 4 viti M8x30 (pos. ①, Fig. 68).

Tarare le 4+4 viti con chiave dinamometrica come indicato nel capitolo 3.

Premontare i due coperchi portacuscinetto:

inserirne il cuscinetto utilizzando una massa battente (pos. ①, Fig. 69) fino ad ottenere una quota di 4 ± 4.5 mm come indicato in Fig. 70.



Fig. 69

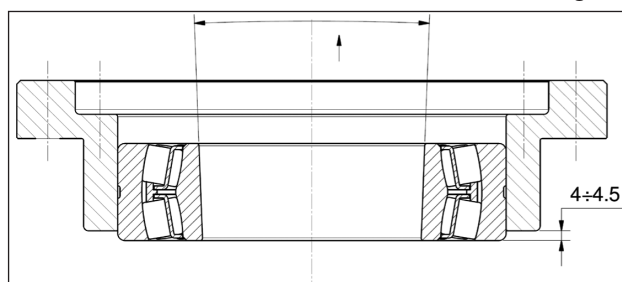

Fig. 70



Il cuscinetto in Fig. 70 ha l'anello interno conico. Verificare che la conicità sia dall'esterno all'interno per permettere il successivo inserimento della bussola.

Applicare l'O-ring all'esterno del coperchio portacuscinetto (pos. ①, Fig. 71).

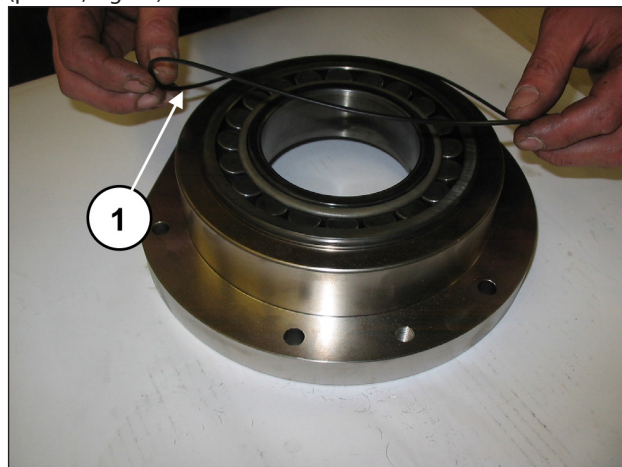

Fig. 71

Ripetere l'operazione con l'altro coperchio.

Bloccare i tre gruppi biella utilizzando l'apposito attrezzo cod. 27566200 (pos. ①, Fig. 40).

Applicare due perni filettati M16 all'estremità dell'albero a gomiti, tenendolo sollevato (pos. ①, Fig. 72), inserire il coperchio portacuscinetto completo di cuscinetto e O-ring (pos. ①, Fig. 73) mediante l'utilizzo di una massa battente. Ripetere l'operazione dal lato opposto

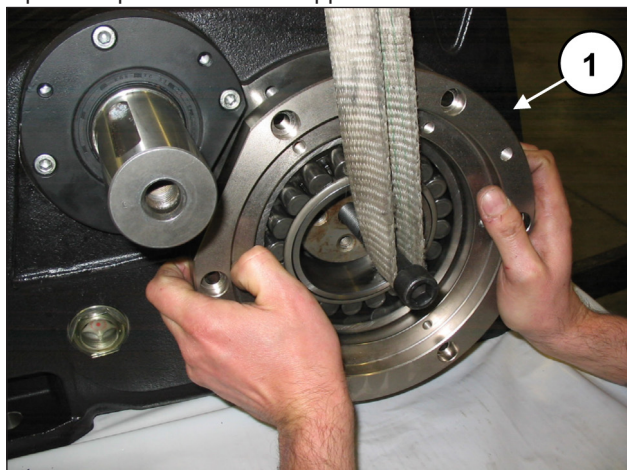

Fig. 72

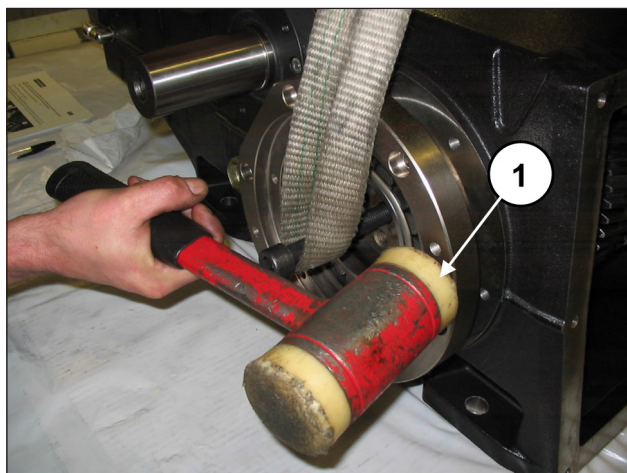

Fig. 73

Serrare i coperchi portacuscinetto mediante 6+6 viti M10x30 (pos. ①, Fig. 74).

Tarare le viti con chiave dinamometrica come indicato nel capitolo 3.

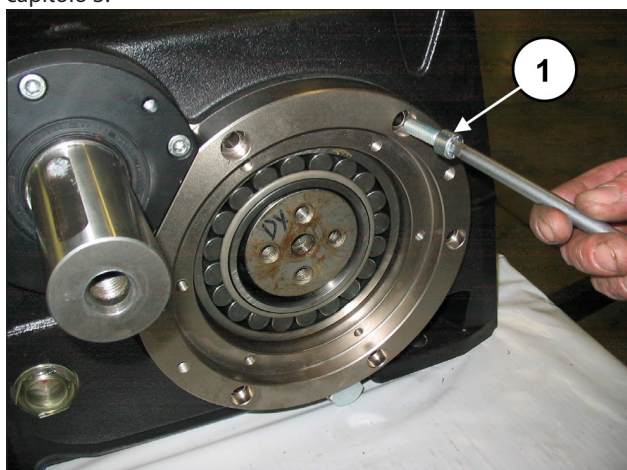

Fig. 74

Inserire parzialmente le due bussole di pressione mantenendo l'albero a gomiti sollevato mediante il perno M16 precedentemente montato (pos. ①, Fig. 75).

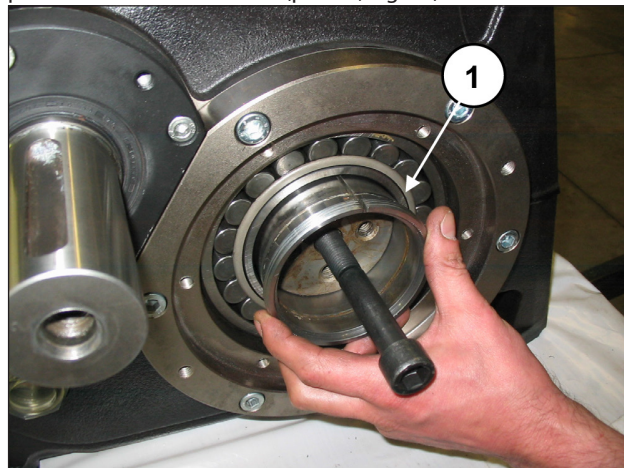

Fig. 75

Inserire completamente la bussola di pressione sull'albero a gomiti (pos. ①, Fig. 76 e Fig. 77) mediante l'utilizzo di una massa battente e di un tampone.

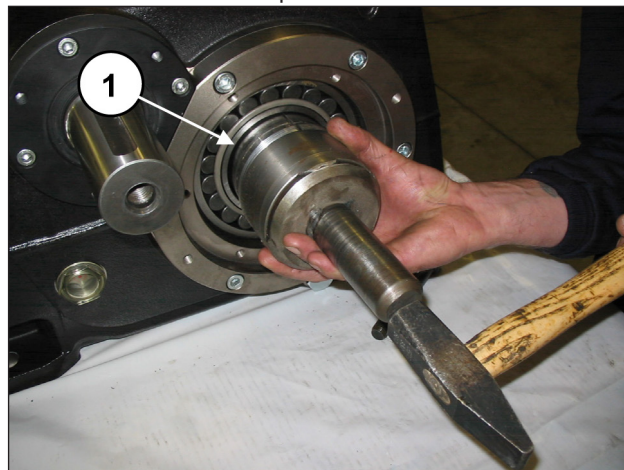

Fig. 76

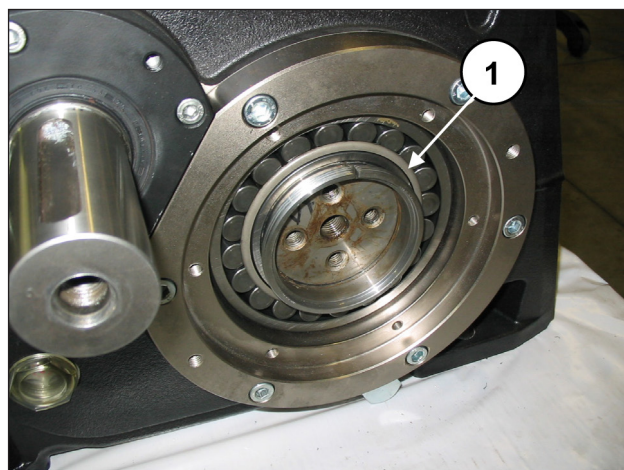

Fig. 77



L'inserimento della bussola di pressione deve essere effettuato a secco (senza oli o lubrificanti).

Inserire la bussola fino a che la superficie esterna (conica) arrivi ad accoppiarsi perfettamente con l'interno del cuscinetto. Durante l'inserimento assicurarsi che il cuscinetto rimanga a contatto con lo spallamento dell'albero a gomiti. Ripetere l'operazione dal lato opposto.

Inserire le flangie bloccaggio bussola all'interno delle bussole coniche (pos. ①, Fig. 78).

Applicare una vite M16 di adeguata lunghezza (35-40 mm) al foro M16 dell'albero a gomiti ed avvitare fino ad appoggiare la flangia contro la bussola (pos. ①, Fig. 79). Non serrare la vite.

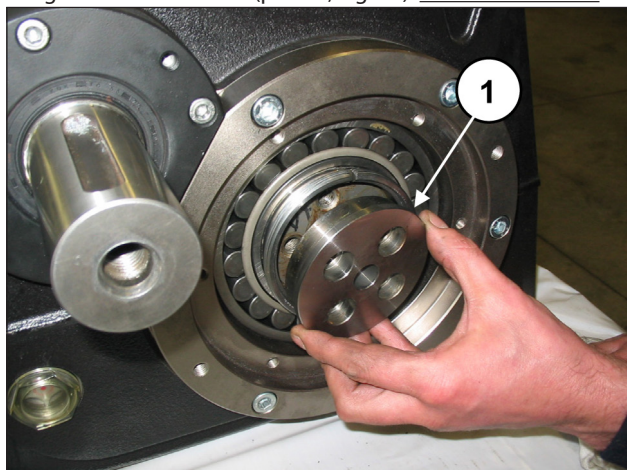

Fig. 78

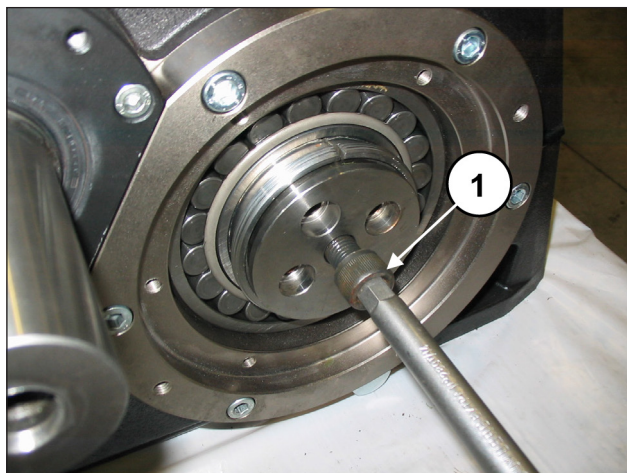

Fig. 79

Ripetere l'operazione dal lato opposto.

Rimuovere l'attrezzo per il bloccaggio delle bielle cod. 27566200 (pos. ①, Fig. 40).

Inserire i semicuscinetti superiori tra le bielle e l'albero a gomiti (pos. ①, Fig. 80).



Per un corretto montaggio dei semicuscinetti assicurarsi che la linguetta di riferimento dei semicuscinetti venga posizionata nell'apposito alloggiamento sulla semibiella (pos. ①, Fig. 81).

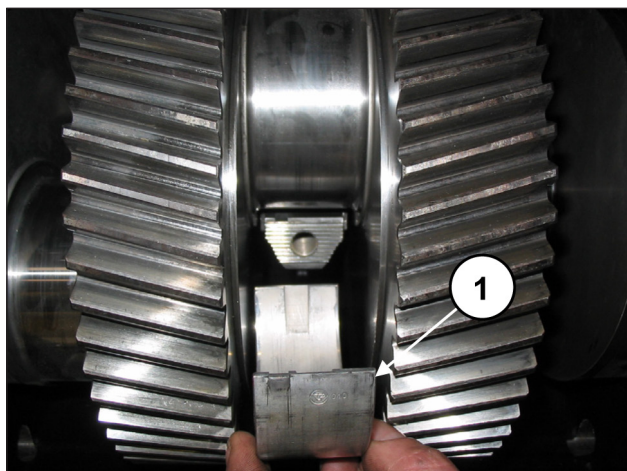

Fig. 80

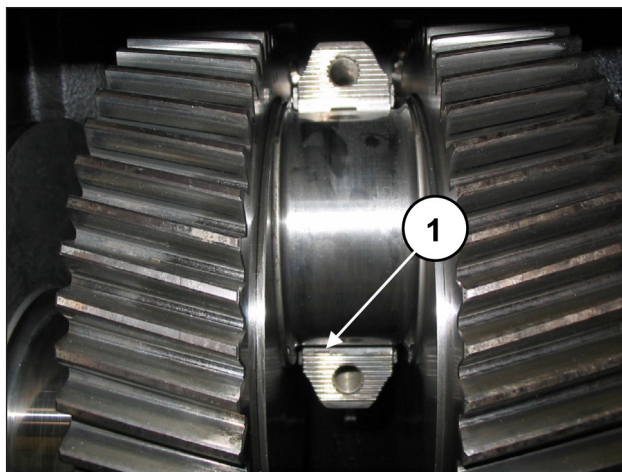

Fig. 81

Applicare i semicuscinetti inferiori ai cappelli (pos. ①, Fig. 82) assicurandosi che la linguetta di riferimento dei semicuscinetti venga posizionata nell'apposito alloggiamento sul cappello (pos. ②, Fig. 82).

Fissare i cappelli alle semibielle mediante le viti M12x1.25x87 (pos. ①, Fig. 83).

Tarare le viti con chiave dinamometrica come indicato nel capitolo 3 portando le viti alla coppia di serraggio contemporaneamente.



Prestare attenzione al corretto senso di montaggio dei cappelli. La numerazione deve essere rivolta verso l'alto.

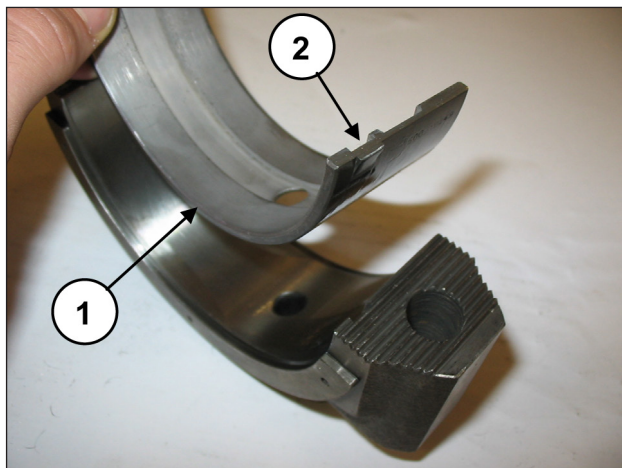

Fig. 82

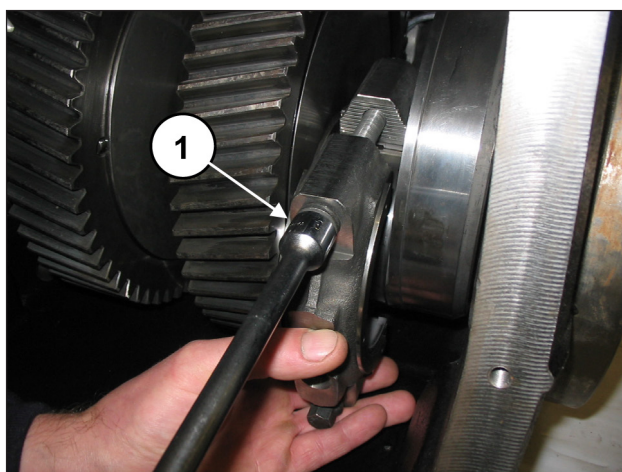

Fig. 83



Ad operazione conclusa verificare che le bielle abbiano gioco assiale in entrambe le direzioni.

Inserire uno spessore sotto al fusto della biella centrale per bloccare la rotazione dell'albero a gomiti (pos. ①, Fig. 84).

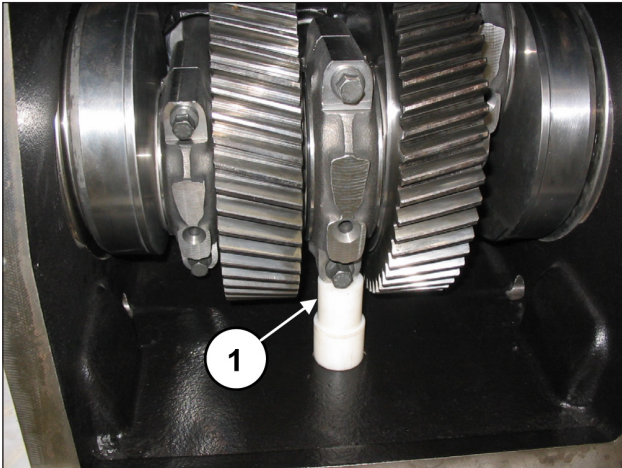

Fig. 84

Misurare la quota "X" indicata in Fig. 85 tra la bussola conica e il cuscinetto albero a gomiti.

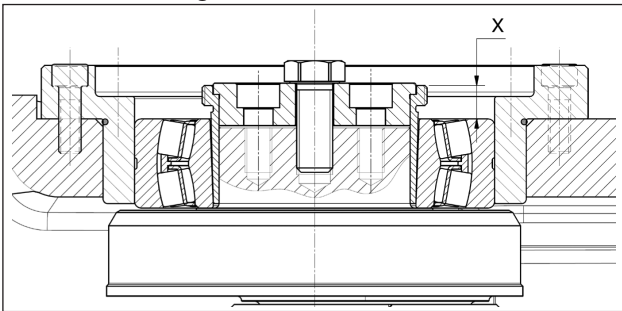

Fig. 85

Avvitare la vite M16 fino determinare una riduzione della quota "X" compresa tra 0.7 e 0.8 mm (Fig. 86).

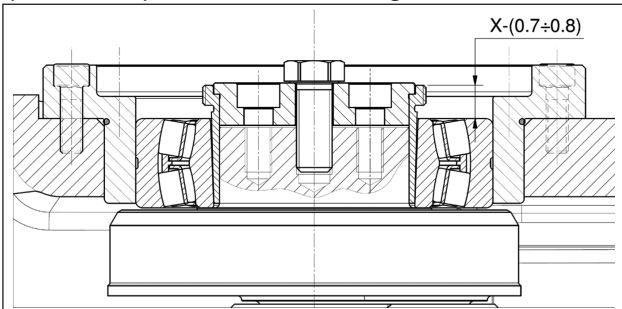

Fig. 86

Ripetere l'operazione dal lato opposto.
Rimuovere la vite M16 dall'albero a gomiti.

Avvitare le due flangie bloccaggio bussola all'albero a gomiti mediante 4+4 viti M12x25 (pos. ①, Fig. 88).



Applicare LOCTITE 243 ai filetti delle viti M12x25 (pos. ①, Fig. 87).

Tarare le viti con chiave dinamometrica come indicato nel capitolo 3.



Fig. 87

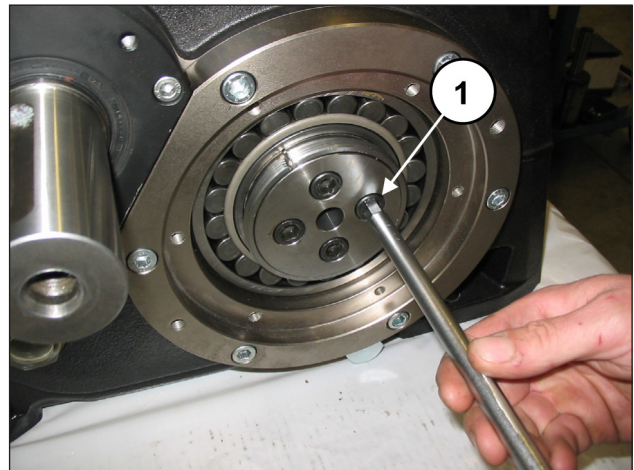

Fig. 88

Rimuovere lo spessore antirotazione sotto al fusto della biella centrale.
Montare i due coperchi cuscinetto (con relativi O-ring) (pos. ①, Fig. 89) mediante 6+6 viti M8x20 (pos. ①, Fig. 90).
Tarare le viti con chiave dinamometrica come indicato nel capitolo 3.

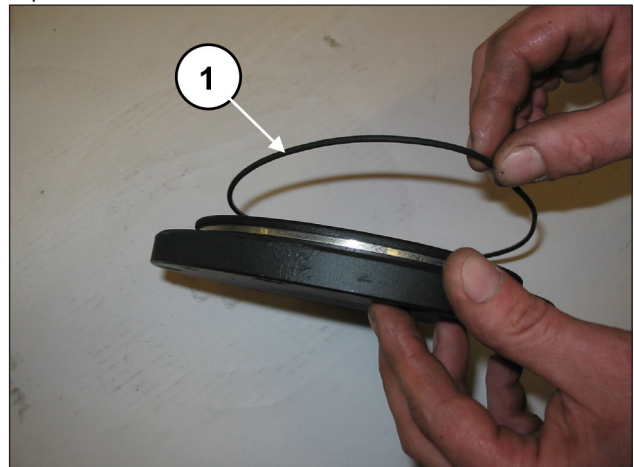

Fig. 89

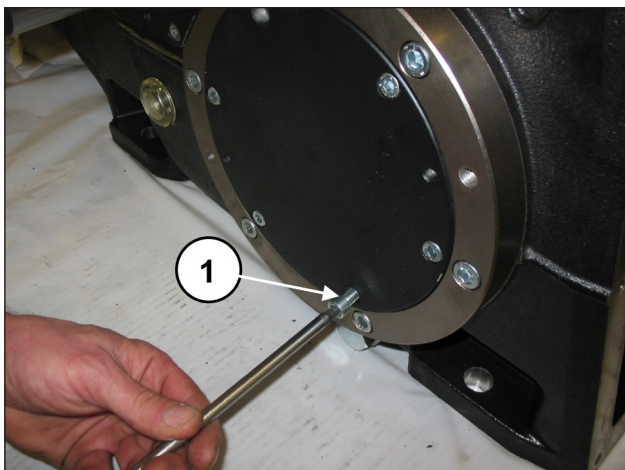

Fig. 90

Inserire l'O-ring nel coperchio posteriore (pos. ①, Fig. 91) e fissarlo al carter mediante 10 viti M8x20 (pos. ①, Fig. 92). Tarare le viti con chiave dinamometrica come indicato nel capitolo 3.

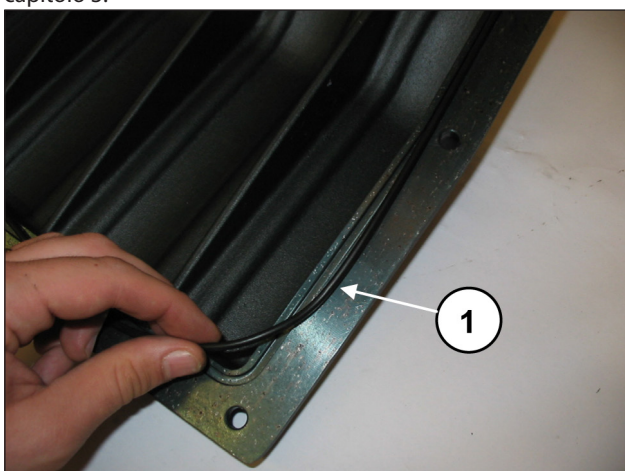

Fig. 91

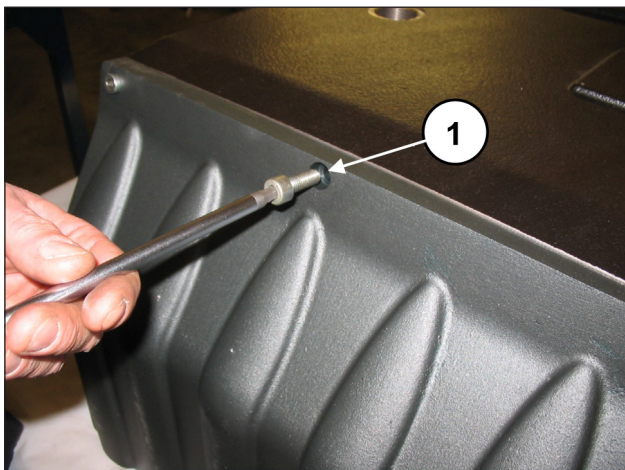

Fig. 92

Montare l'anello di tenuta radiale nel coperchio paraolio (pos. ①, Fig. 93) mediante l'utilizzo di un tampone cod. 27910900.

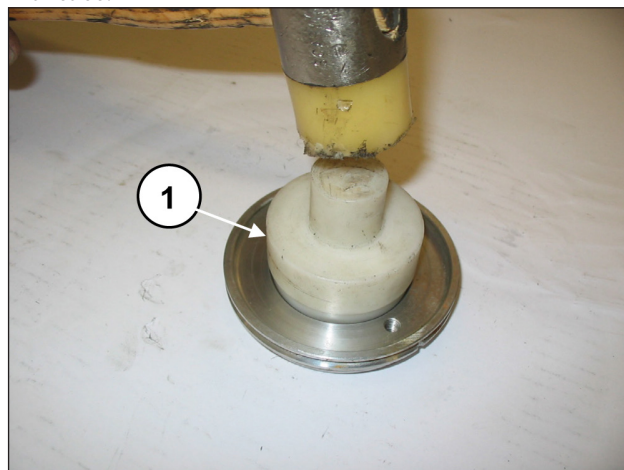

Fig. 93

Posizionare l'O-ring (pos. ①, Fig. 94) nella sede del coperchio paraolio.

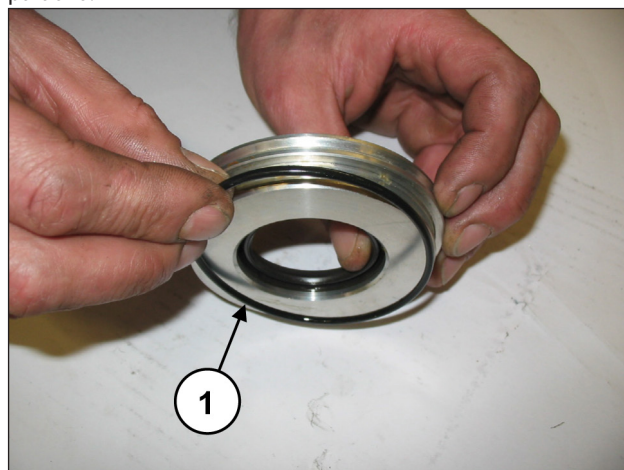

Fig. 94

Inserire il gruppo montato all'interno del carter nell'apposita sede assicurandosi che il coperchio entri completamente in sede (pos. ①, Fig. 95) facendo attenzione a non danneggiare il labbro dell'anello di tenuta radiale. Avvitare i coperchi paraolio mediante 2 grani M6x30 (pos. ①, Fig. 96).

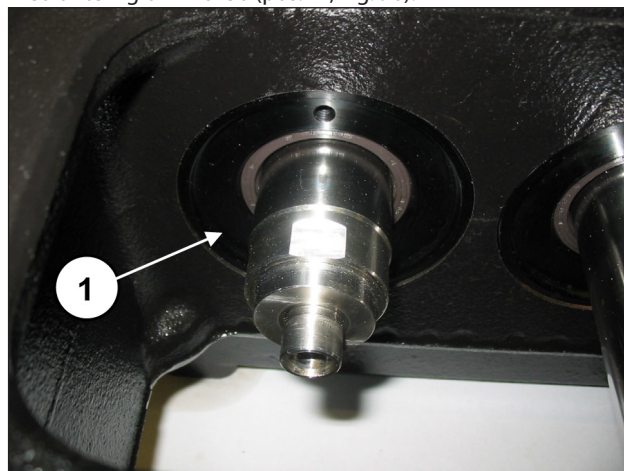

Fig. 95

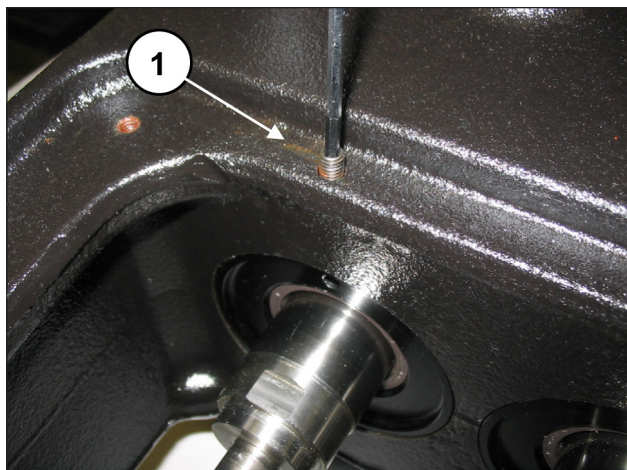

Fig. 96

Tarare le viti con chiave dinamometrica come indicato nel capitolo 3.
Posizionare il paraspruzzi e l'anello distanziale paraspruzzi nell'alloggiamento sullo stelo guida pistone (pos. ①, Fig. 97 e Fig. 98).

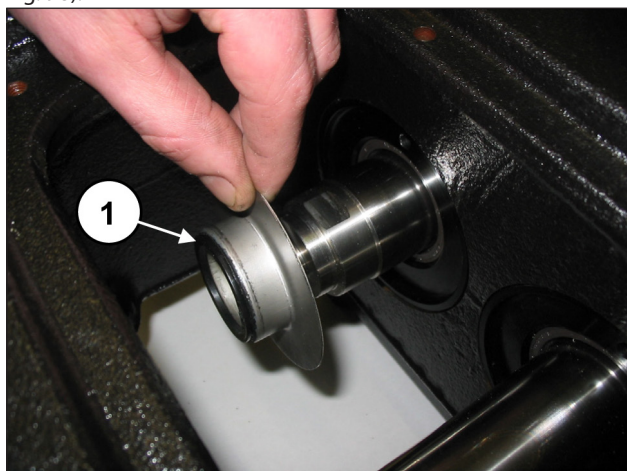

Fig. 97

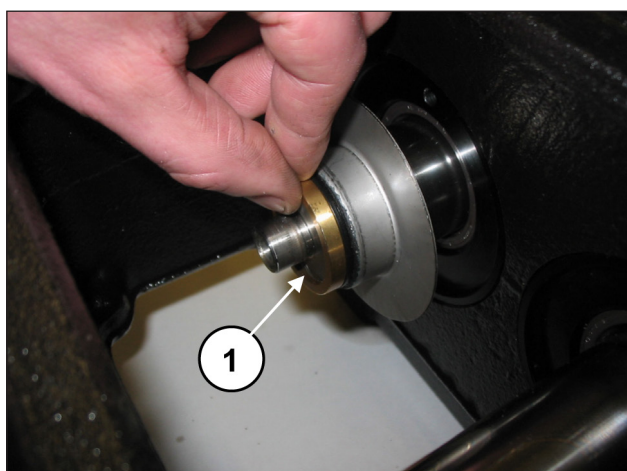

Fig. 98

Sui due coperchi ispezione inserire l'O-ring (pos. ①, Fig. 99) e montare i coperchi mediante l'utilizzo di 4+4 viti M6x14 (pos. ①, Fig. 100).

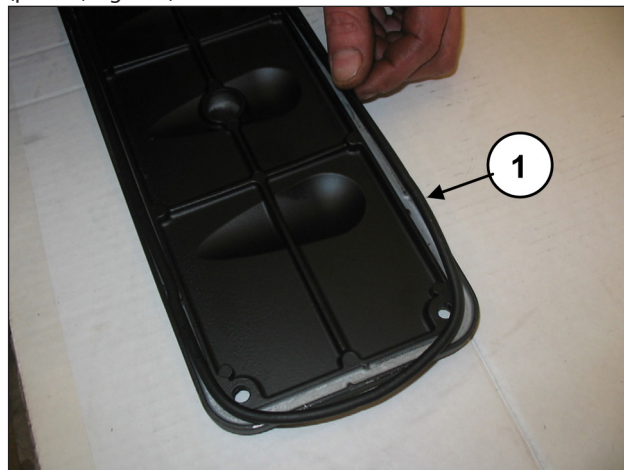

Fig. 99

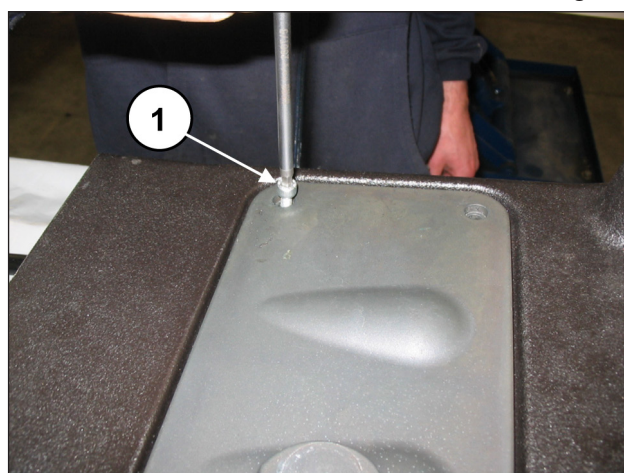

Fig. 100

Tarare le viti con chiave dinamometrica come indicato nel capitolo 3 "Tarature serraggio viti".
Montare il coperchio estremità albero e fissarlo al carter mediante 3 viti M8x20 (pos. ①, Fig. 101).
Tarare le viti con chiave dinamometrica come indicato nel capitolo 3 "Tarature serraggio viti".



Fig. 101

Applicare la linguetta sull'albero PTO (pos. ①, Fig. 102).

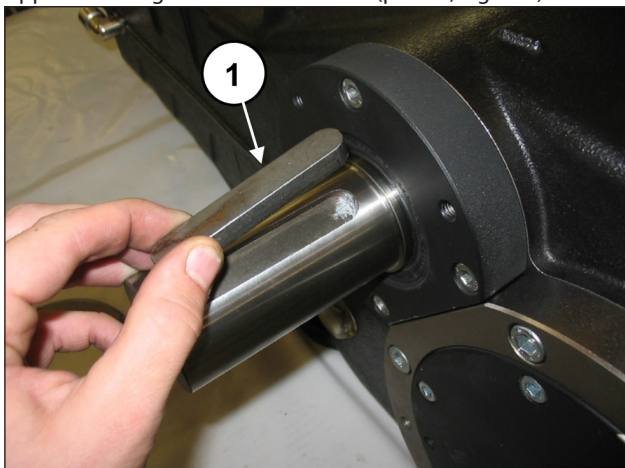

Fig. 102

2.1.3 Classi di maggiorazione previste

TABELLA MAGGIORAZIONE PER ALBERO A GOMITI E SEMICUSCINETTI DI BIELLA			
Classi di recupero (mm)	Codice Semicuscinetto Superiore	Codice Semicuscinetto Inferiore	Rettifica sul diametro perno dell'albero (mm)
0.25	90931100	90930100	Ø92.75 0/-0.03 Ra 0.4 Rt 3.5
0.50	90931200	90930200	Ø92.50 0/-0.03 Ra 0.4 Rt 3.5

TABELLA MAGGIORAZIONE PER CARTER POMPA E GUIDA PISTONE		
Classi di recupero (mm)	Codice Guida Pistone	Rettifica sulla sede Carter Pompa (mm)
1.00	79050543	Ø81 H6 +0.022/0 Ra 0.8 Rt 6

2.2 RIPARAZIONE DELLA PARTE IDRAULICA

2.2.1 Smontaggio della testata - gruppi valvole

La testata necessita di una manutenzione preventiva come indicato nel **Manuale uso e manutenzione**.

Gli interventi sono limitati all'ispezione o sostituzione delle valvole, qualora necessario.

Per l'estrazione dei gruppi valvola operare come segue: Svitare il dispositivo apertura valvole mediante chiave da 30 mm (pos. ①, Fig. 103).

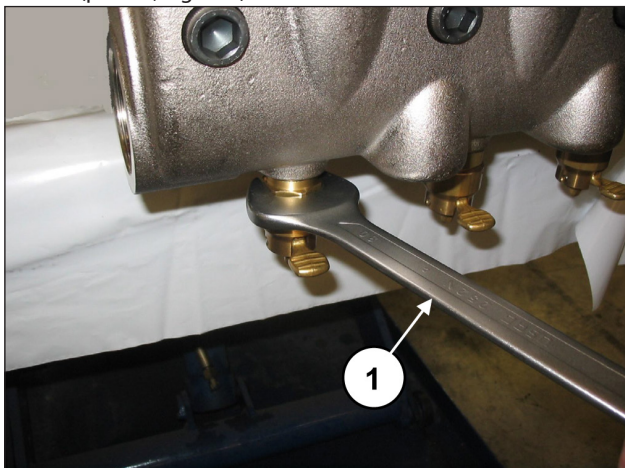

Fig. 103

Applicare due sostegni con filettatura G2" agli attacchi di mandata della testata (pos. ①, Fig. 104) e successivamente svitare le 8 viti M16x150 (pos. ①, Fig. 105).

Prestare attenzione a non urtare i pistoni durante l'estrazione della testata.

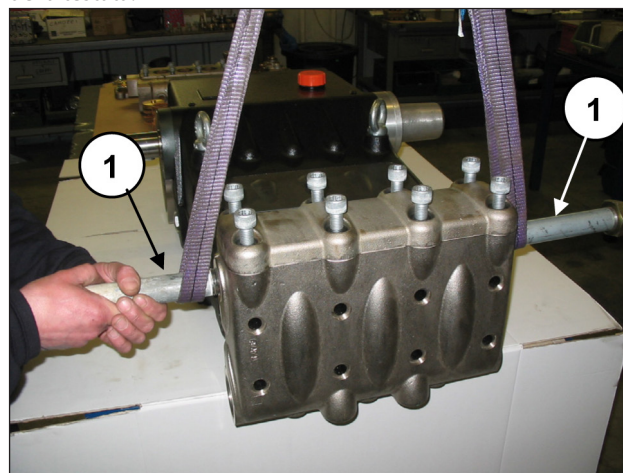

Fig. 104

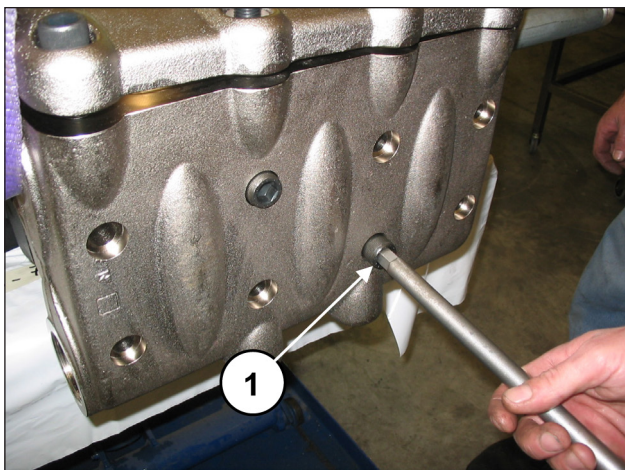

Fig. 105

Estrarre le 8 viti M16x55 del coperchio valvole (pos. ①, Fig. 106) e rimuovere il coperchio (pos. ①, Fig. 107).



Fig. 106

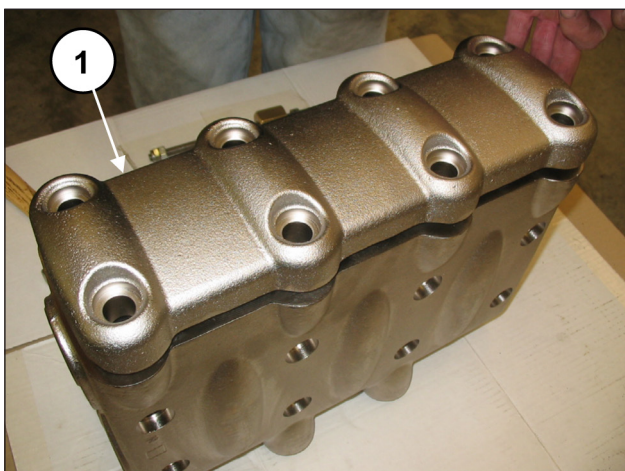

Fig. 107

Estrarre il tappo valvola mediante l'utilizzo di un estrattore a massa battente da applicare al foro M10 del tappo valvola (pos. ①, Fig. 108).

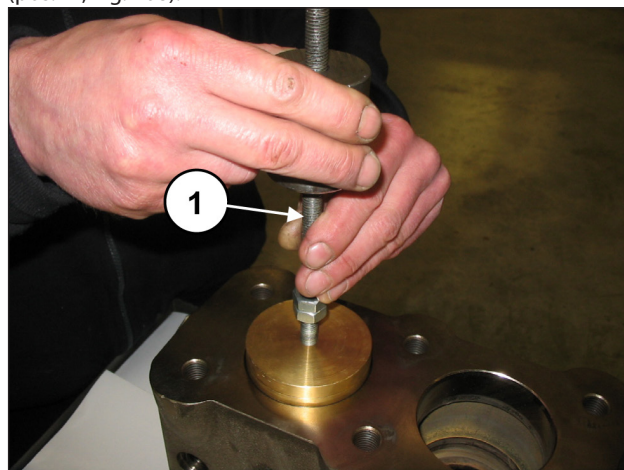

Fig. 108

Sfilare la molla (pos. ①, Fig. 109).

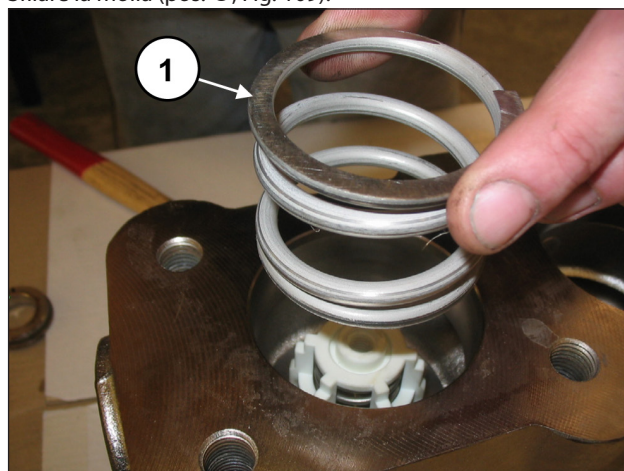

Fig. 109

Estrarre il gruppo valvola mandata mediante l'utilizzo di un estrattore a massa battente da applicare al foro M10 del guida valvola (pos. ①, Fig. 110).

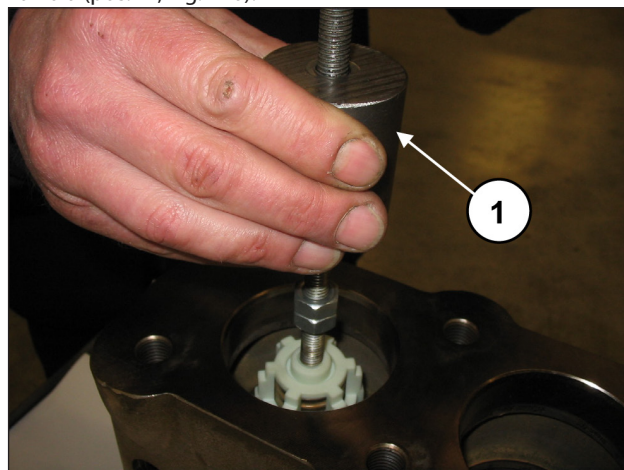

Fig. 110



Qualora l'estrazione del gruppo valvola di mandata risultasse particolarmente difficoltosa (ad es. per incrostazioni dovute ad un prolungato inutilizzo della pompa) utilizzare l'attrezzo estrattore cod. 27516400.

Estrarre il distanziale guida valvola mediante l'utilizzo di una chiave esagonale da 8 mm (pos. ①, Fig. 111).

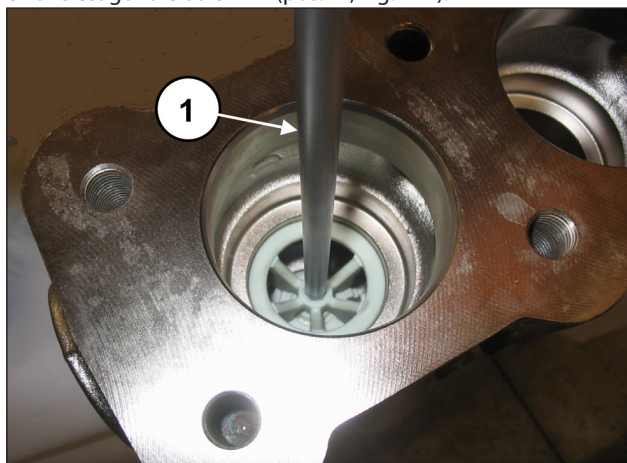

Fig. 111

Estrarre il gruppo valvola aspirazione mediante l'utilizzo di un estrattore a massa battente da applicare al foro M10 del guida valvola (pos. ①, Fig. 112).

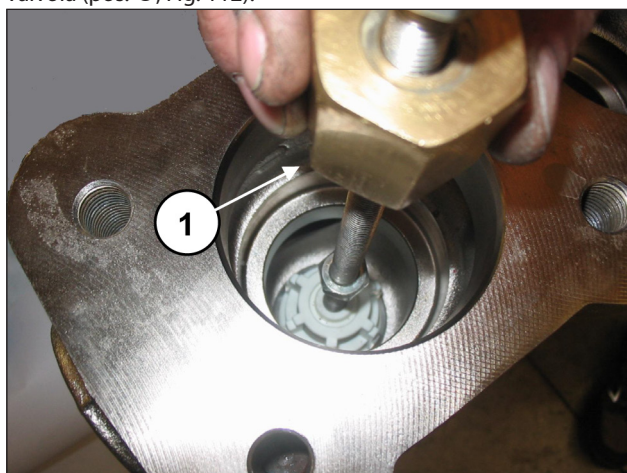

Fig. 112



Qualora l'estrazione del gruppo valvola di aspirazione risultasse particolarmente difficoltosa (ad es. per incrostazioni dovute ad un prolungato inutilizzo della pompa) utilizzare l'attrezzo estrattore cod. 27516200 (per LK36-LK40-LK45) o cod. 27516300 (per LK50-LK55-LK60) (pos. ①, Fig. 113) ed agire come indicato.

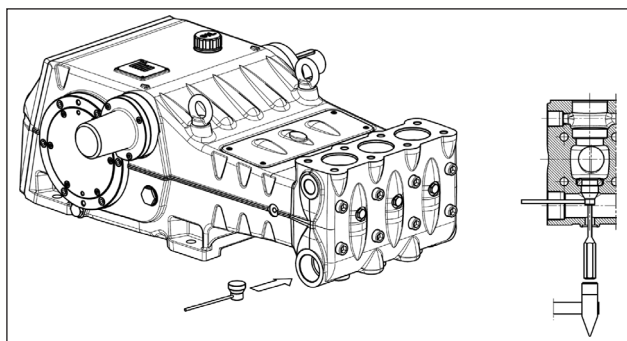

Fig. 113

Smontare i gruppi valvola di aspirazione e mandata avvitando una vite M10 in modo da premere sulla guida interna ed estrarre il guida valvola dalla sede valvola (pos. ①, Fig. 114).

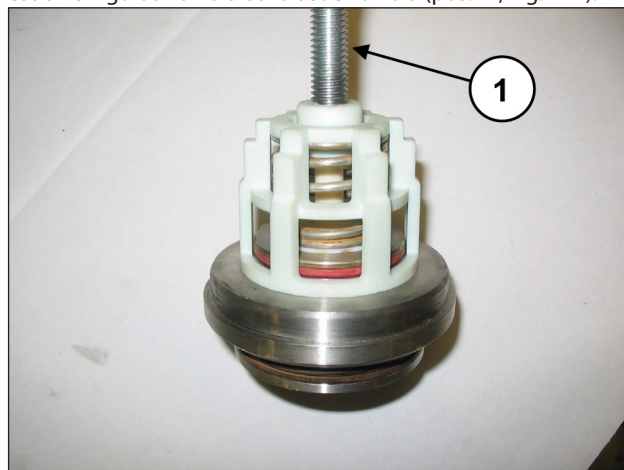

Fig. 114

2.2.2 Montaggio della testata - gruppi valvole



Prestare particolare attenzione allo stato di usura dei vari componenti e sostituirli qualora necessario.

Ad ogni ispezione delle valvole sostituire tutti gli O-ring sia dei gruppi valvola che dei tappi valvola.



Prima di riposizionare i gruppi valvola pulire ed asciugare perfettamente i relativi alloggiamenti nella testata indicati dalle frecce (pos. ①, Fig. 115).

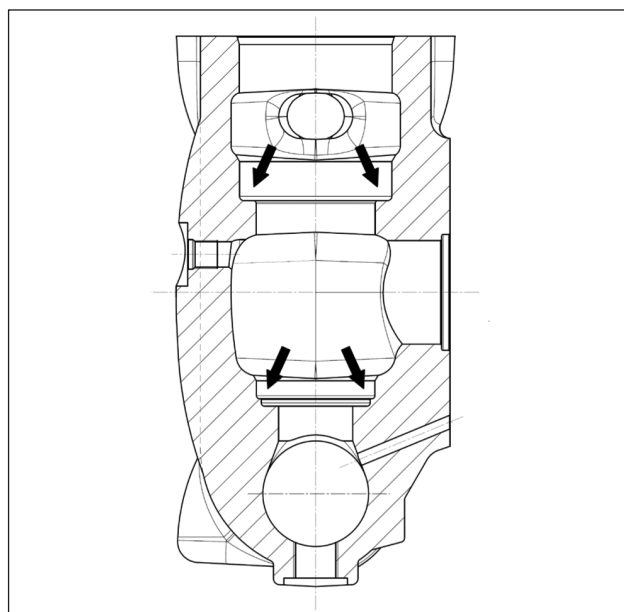

Fig. 115

Procedere al rimontaggio seguendo il procedimento inverso allo smontaggio indicato al par. 2.2.1.

Assemblare i gruppi valvola di aspirazione e mandata (Fig. 116 e Fig. 117) prestando attenzione a non invertire le molle precedentemente smontate.

Per facilitare l'inserimento della guida valvola nella sede si può utilizzare un tubo che appoggi sui pianetti orizzontali della guida (Fig. 118) e utilizzare una massa battente agendo su tutta la circonferenza



Fig. 116



Fig. 117

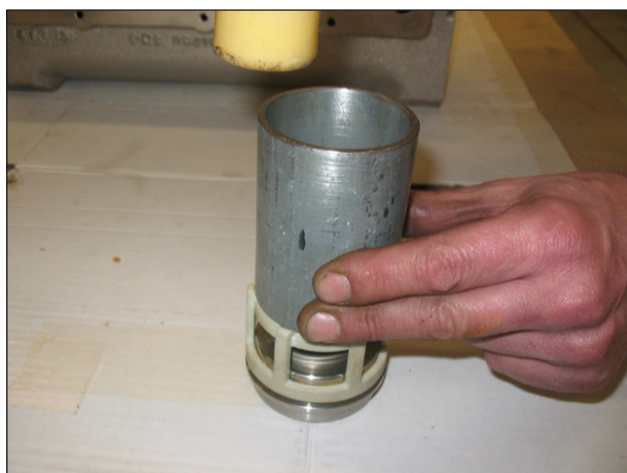

Fig. 118



Procedere con l'inserimento dei gruppi valvola (aspirazione e mandata) nella testata prestando attenzione alla sequenza corretta di inserimento degli O-ring e degli anelli antiestrusione.

La corretta sequenza di montaggio dei gruppi valvola nella testata è la seguente:

Inserire l'anello antiestrusione, pos. esploso n. 4 (pos. ①, Fig. 119).

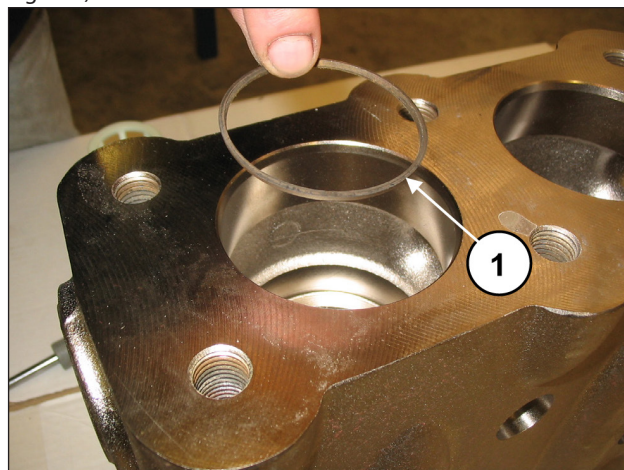

Fig. 119

Inserire l'O-ring, pos. esploso n. 5 (pos. ①, Fig. 120).

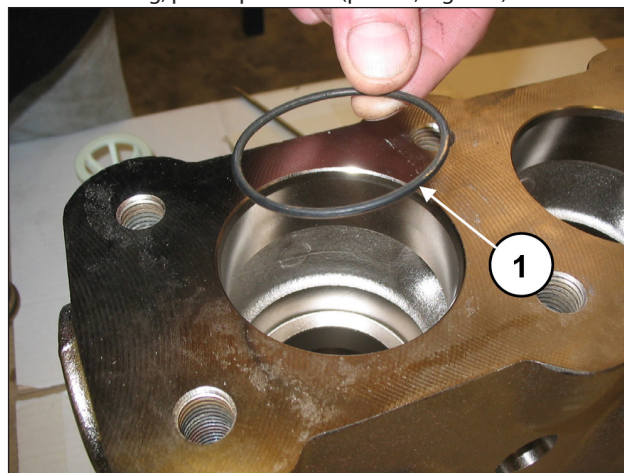

Fig. 120

Accertarsi che O-ring e anello antiestrusione vengano alloggiati perfettamente in sede.

Inserire il gruppo valvola di aspirazione (pos. ①, Fig. 121) e successivamente il distanziale (pos. ①, Fig. 122).

Il gruppo valvola completo deve essere inserito completamente a fondo e presentarsi come in pos. ①, Fig. 122.

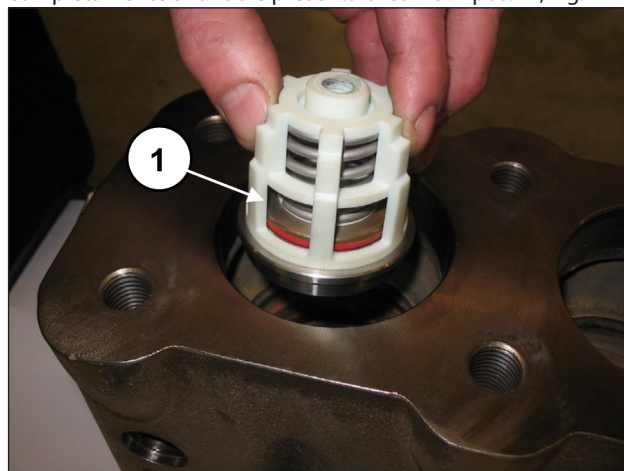

Fig. 121

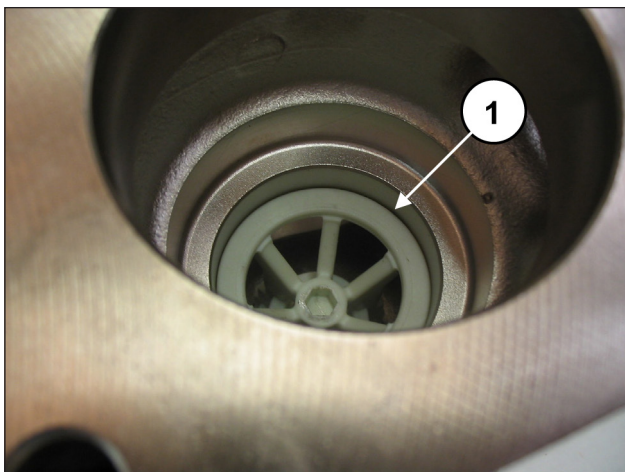

Fig. 122

Montare O-ring, pos. esploso n. 5 (pos. ①, Fig. 123) e anello antiestrusione, pos. esploso n. 15 (pos. ②, Fig. 123) sulla sede e valvola di mandata.

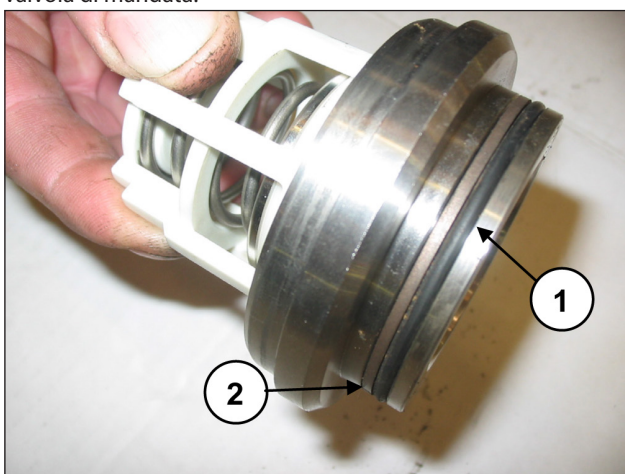

Fig. 123

Inserire il gruppo valvola di mandata (pos. ①, Fig. 124). Il gruppo valvola deve essere inserito completamente a fondo e presentarsi come in pos. ①, Fig. 125.

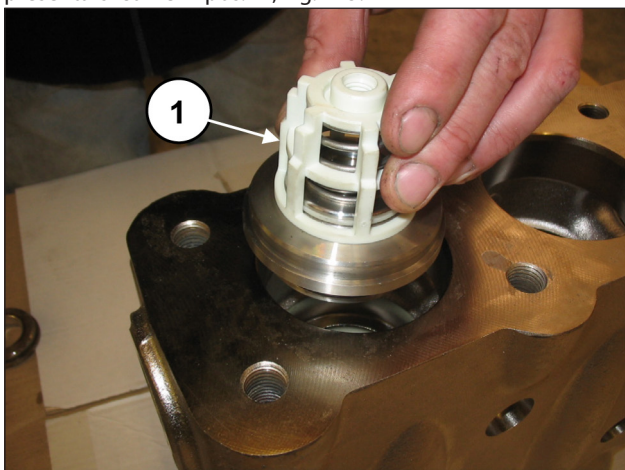

Fig. 124

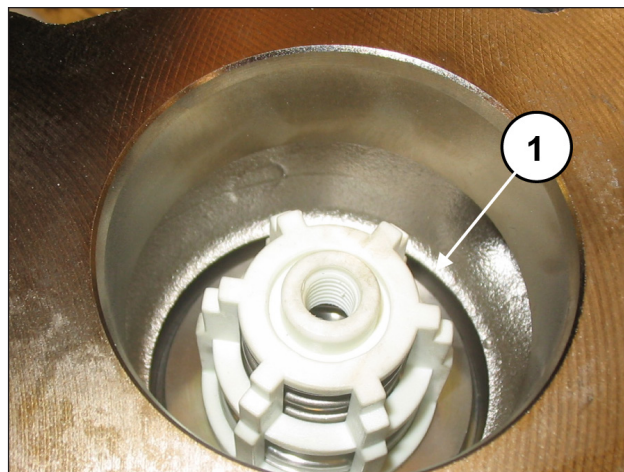

Fig. 125

Inserire l'anello antiestrusione, pos. esploso n. 16 (pos. ①, Fig. 126).

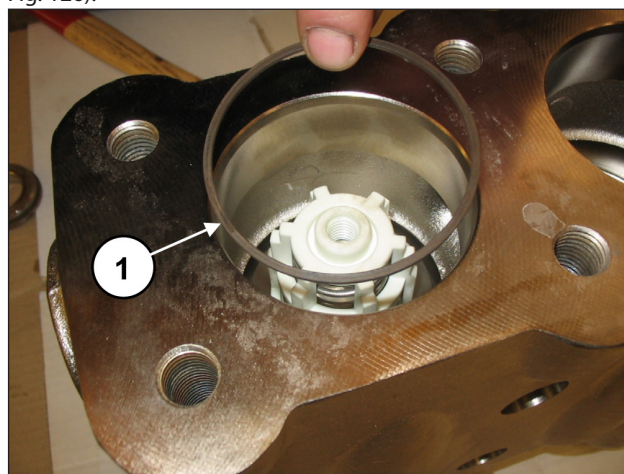

Fig. 126

Inserire l'O-ring, pos. esploso n. 17 (pos. ①, Fig. 127).

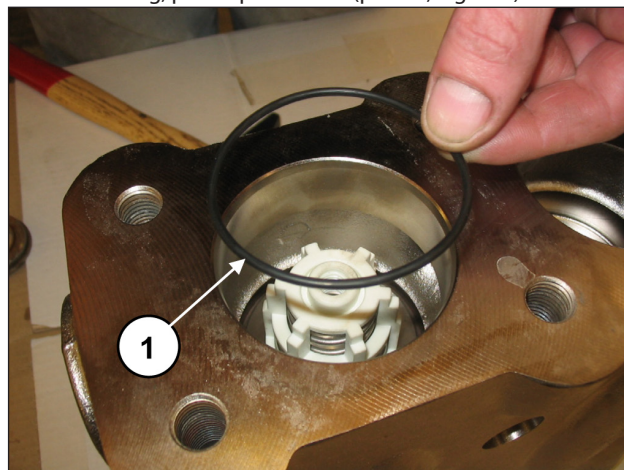

Fig. 127



Prestare particolare attenzione all'inserimento dell'O-ring indicato in pos. ①, Fig. 128. Si consiglia l'utilizzo dell'attrezzo cod. 27516000 (per LK36-LK40-LK45) o cod. 27516100 (per LK50-LK55-LK60) per evitare che l'O-ring possa tagliarsi durante l'inserimento.

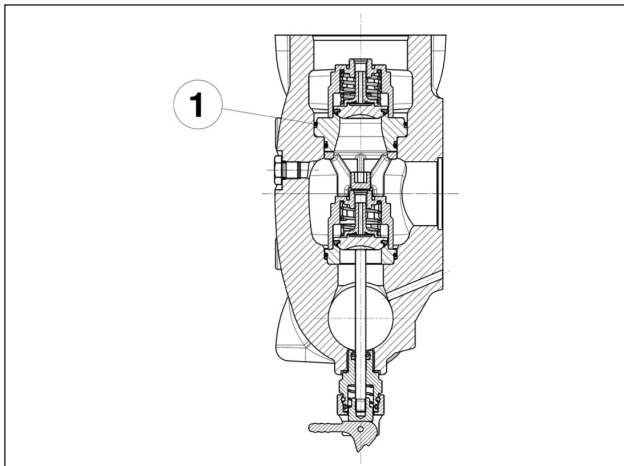

Fig. 128

Inserire l'anello sede valvola (pos. ①, Fig. 129) e la molla (pos. ①, Fig. 130).

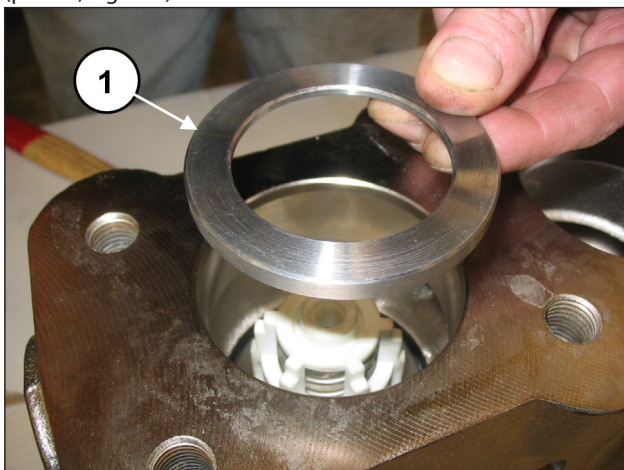

Fig. 129

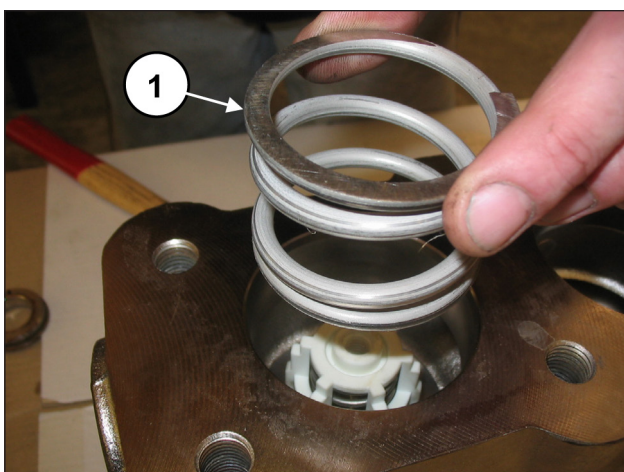

Fig. 130

Montare O-ring, pos. esploso n. 17 (pos. ①, Fig. 131) e anello antiestrusione, pos. esploso n. 21 (pos. ②, Fig. 131) sul tappo valvola di mandata.

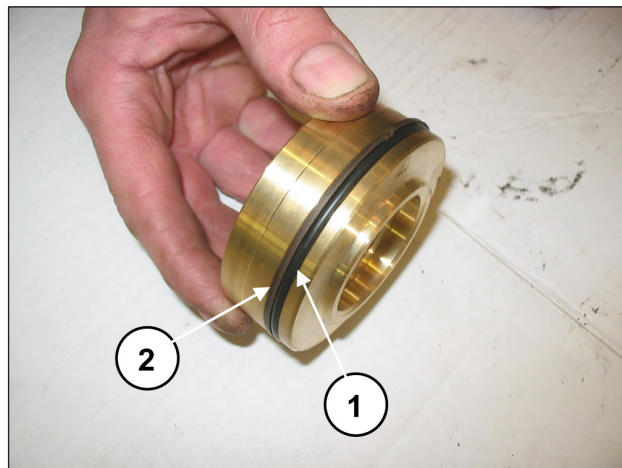

Fig. 131

Inserire il tappo valvola completo di O-ring e anelli antiestrusione.

Dopo aver terminato il montaggio dei gruppi valvola e del tappo valvola applicare il coperchio valvole (pos. ①, Fig. 132) e avvitare le 8 viti M16x55 (pos. ①, Fig. 133).

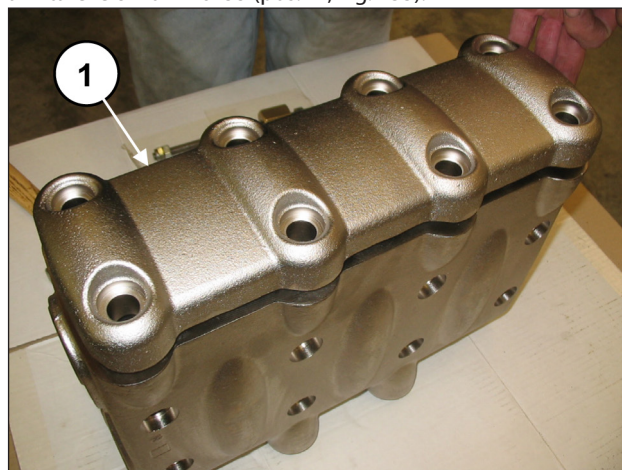

Fig. 132

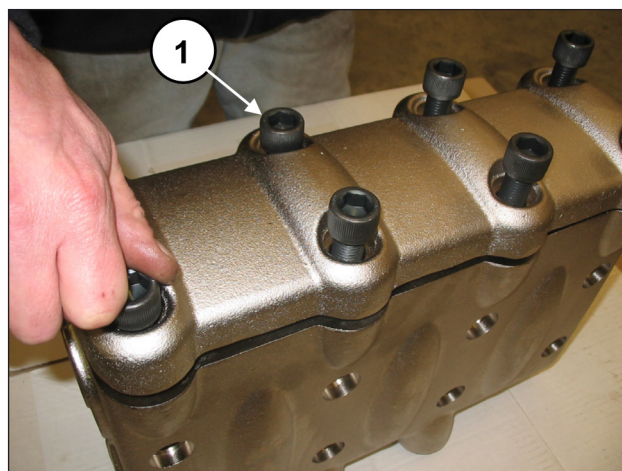

Fig. 133

Montare la testata sul carter pompa (pos. ①, Fig. 134) facendo attenzione a non urtare i pistoni ed avvitare le 8 viti M16x150 (pos. ①, Fig. 135).

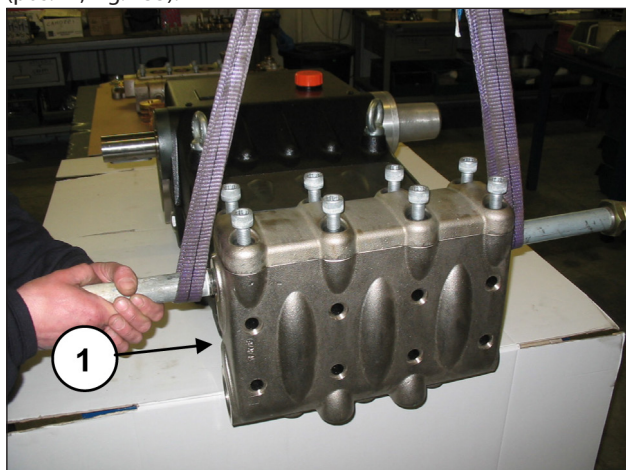

Fig. 134

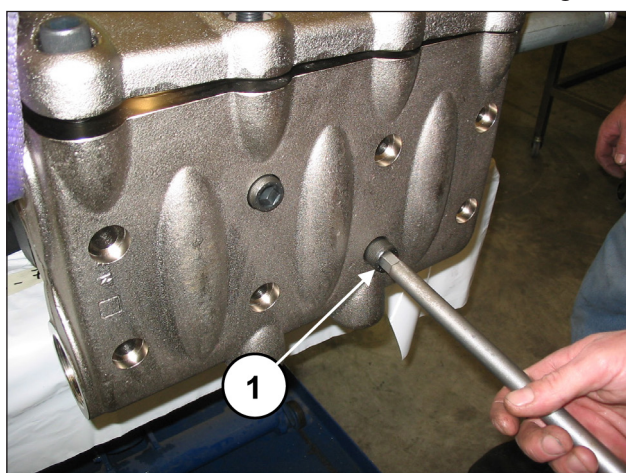

Fig. 135

Procedere alla taratura delle viti M16x150 con chiave dinamometrica come indicato nel capitolo 3 "Tarature serraggio viti".



Serrare le 8 viti M16x150 partendo dalle 4 viti interne in modo incrociato (vedere Fig. 135), per poi proseguire con le 4 viti esterne, sempre serrando in modo incrociato

Tarare le viti M16x55 del coperchio con chiave dinamometrica come indicato nel capitolo 3 "Tarature serraggio viti".

Applicare i dispositivi apertura valvole (pos. ①, Fig. 136) ed avvitarli mediante chiave da 30 mm (pos. ①, Fig. 137).

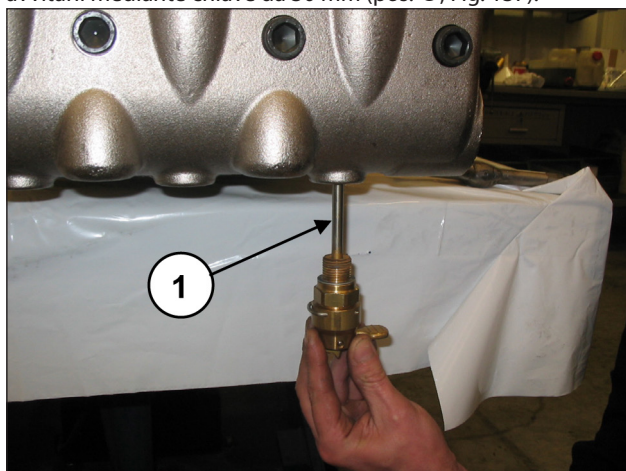

Fig. 136

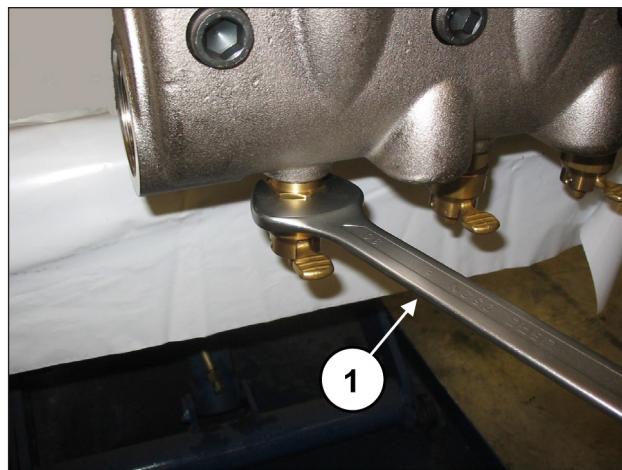

Fig. 137

2.2.3 Smontaggio del gruppo pistone - supporti - tenute

Il gruppo pistone necessita di una verifica periodica come indicato nella tabella di manutenzione preventiva del **Manuale uso e manutenzione**.

Gli interventi sono limitati al solo controllo visivo dell'eventuale drenaggio dal foro presente sul coperchio inferiore. Qualora si presentassero anomalie / oscillazioni sul manometro di mandata o gocciolamenti dal foro di drenaggio, sarà necessario procedere al controllo e alla eventuale sostituzione del pacco tenute.

Per l'estrazione dei gruppi pistone operare come segue: Per accedere al gruppo pistone occorre svitare le viti M16x150 e smontare la testata.



Sfilare la testata con il massimo di attenzione per evitare di urtare i pistoni.

Provvedere allo smontaggio dei pistoni svitando le viti di fissaggio (pos. ①, Fig. 138).

Sfilare il pistone dal supporto guarnizioni e controllare che la superficie dello stesso non presenti graffi, segni di usura o di cavitazione

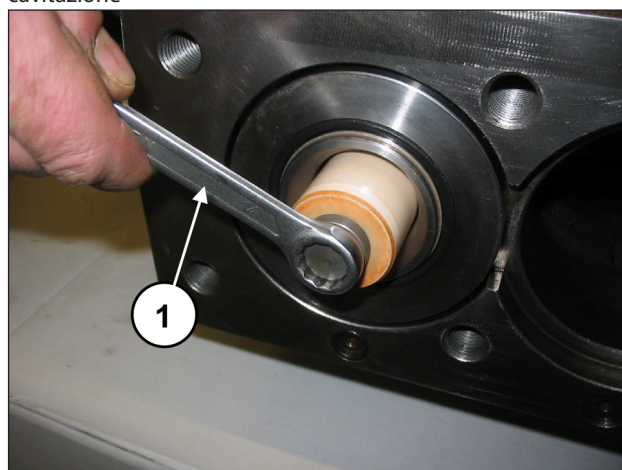

Fig. 138

Rimuovere il coperchio di ispezione superiore (pos. ①, Fig. 139) e inferiore (pos. ①, Fig. 140) svitando le 4+4 viti di fissaggio.

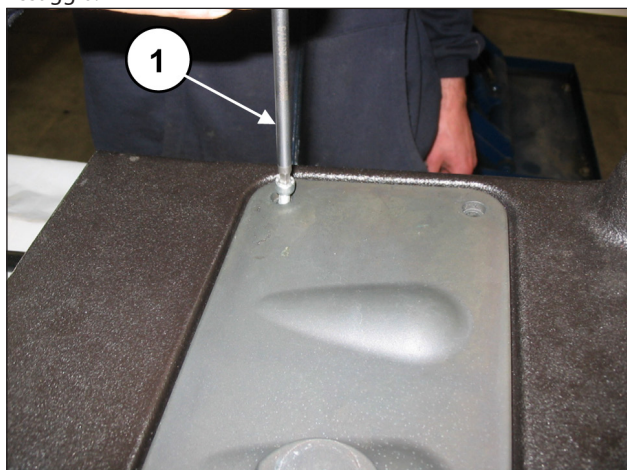

Fig. 139

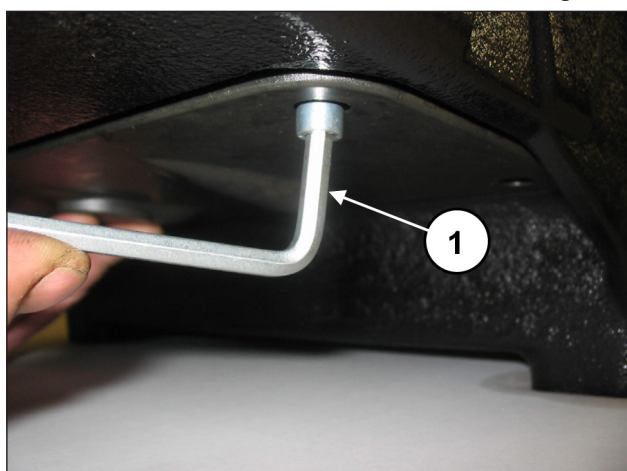

Fig. 140

Ruotare manualmente l'albero in modo da portare i 3 pistoni nella posizione di punto morto superiore. Inserire l'attrezzo tampone cod. 27516600 tra il guida pistone e il pistone (pos. ①, Fig. 141).

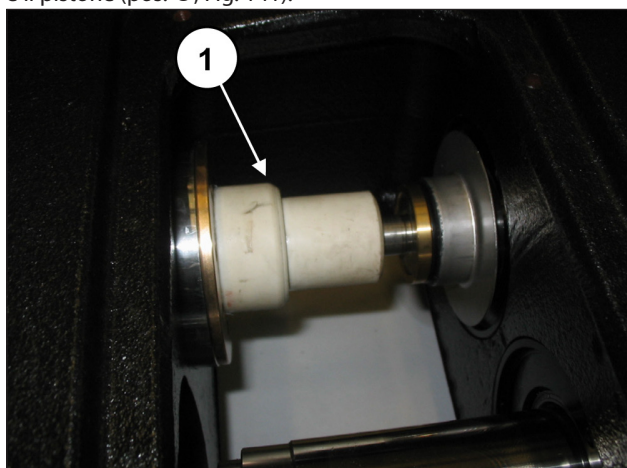

Fig. 141

Ruotando l'albero, fare avanzare il guida pistone in modo che il tampone, avanzando a sua volta, possa espellere il supporto guarnizioni e tutto il gruppo pistone (pos. ①, Fig. 142).

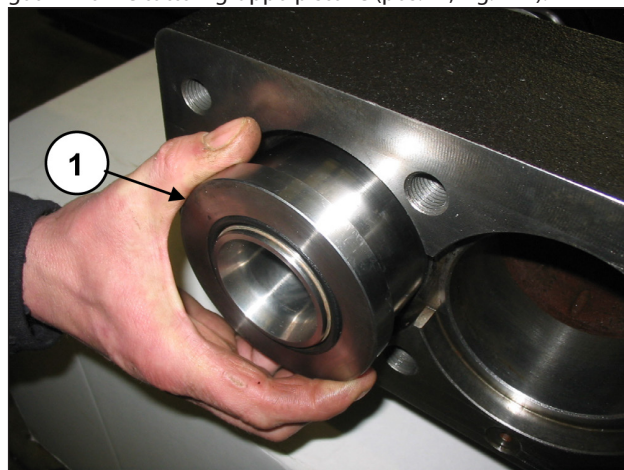

Fig. 142

Estrarre il gruppo supporto guarnizioni e l'attrezzo tampone. Sfilare dai guida pistoni gli anelli distanziali paraspruzzi (pos. ①, Fig. 143) e i paraspruzzi (pos. ①, Fig. 144).

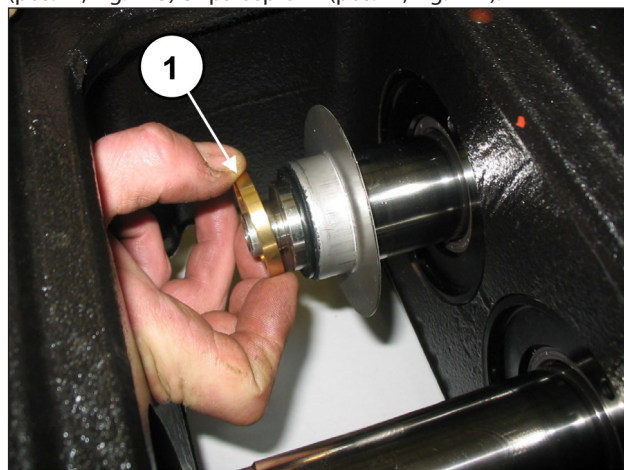

Fig. 143



Fig. 144

Separare il supporto guarnizioni dalla camicia mediante l'utilizzo di una chiave a compasso con naselli tondi Ø5, reperibile sul mercato, (pos. ①, Fig. 145) e svitare il supporto fino alla sua completa estrazione (pos. ①, Fig. 146).

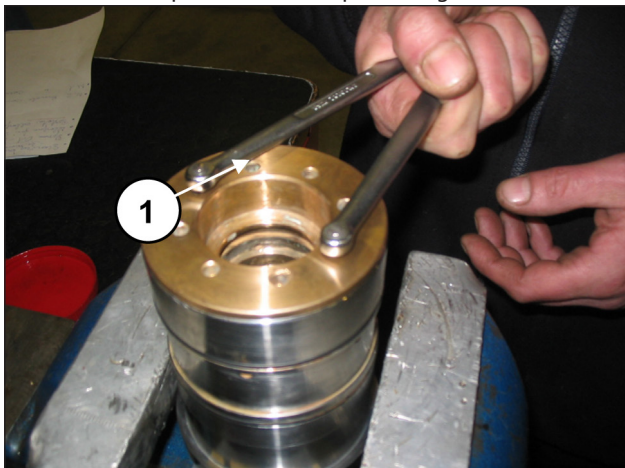

Fig. 145



Fig. 146

Estrarre manualmente gli anelli di testa, le guarnizioni di pressione e gli anelli restop (pos. ①, Fig. 147).



Fig. 147

Per togliere la guarnizione di bassa pressione è necessario utilizzare uno spessimetro o un attrezzo che non danneggi la sede del supporto guarnizione (pos. ①, Fig. 148).

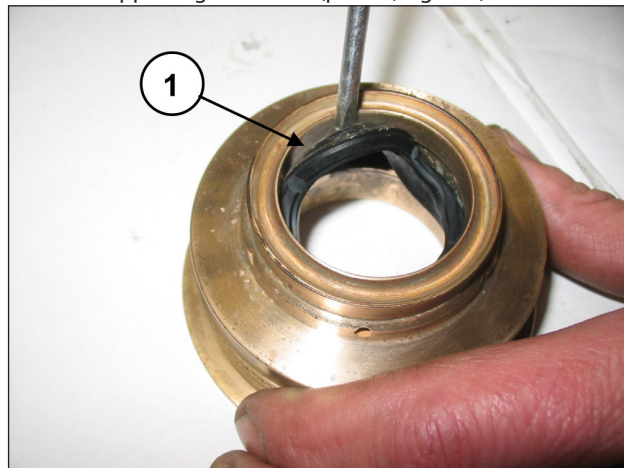

Fig. 148

2.2.4 Montaggio del gruppo pistone - supporti - tenute

Procedere al rimontaggio seguendo il procedimento inverso allo smontaggio indicato al par. 2.2.3.



Sostituire le guarnizioni di pressione inumidendone i labbri con grasso al silicone (senza cospargerle), facendo molta attenzione a non danneggiarle durante l'inserimento nella camicia.



Ad ogni smontaggio le guarnizioni di pressione devono essere sempre sostituite assieme a tutti gli O-ring.

Inserire la guarnizione di bassa pressione nel supporto guarnizione (pos. ①, Fig. 149) facendo attenzione al senso di montaggio che prevede il labbro di tenuta in avanti (verso la testata).

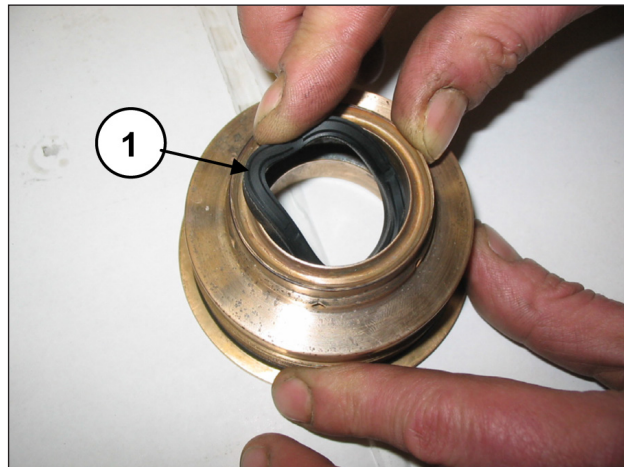

Fig. 149

Montare l'anello di testa (pos. ①, Fig. 150), la guarnizione di alta pressione (pos. ①, Fig. 151) e l'anello restop (pos. ①, Fig. 152).

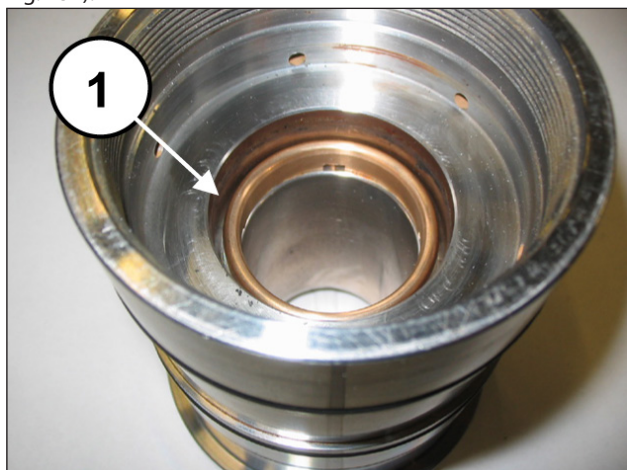

Fig. 150

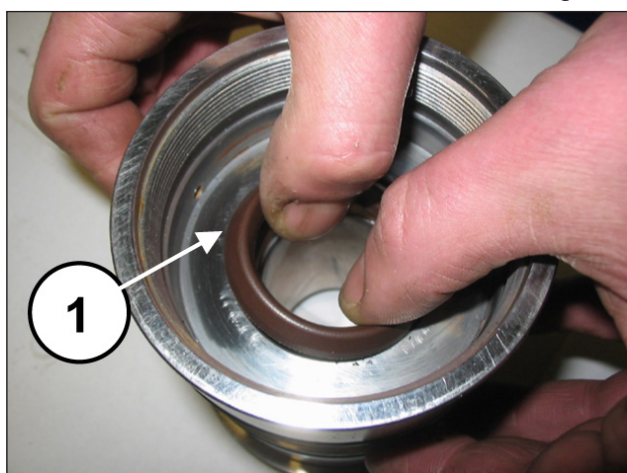

Fig. 151



Fig. 152

Inserire l'O-ring del supporto guarnizione nell'apposita sede (pos. ①, Fig. 153).

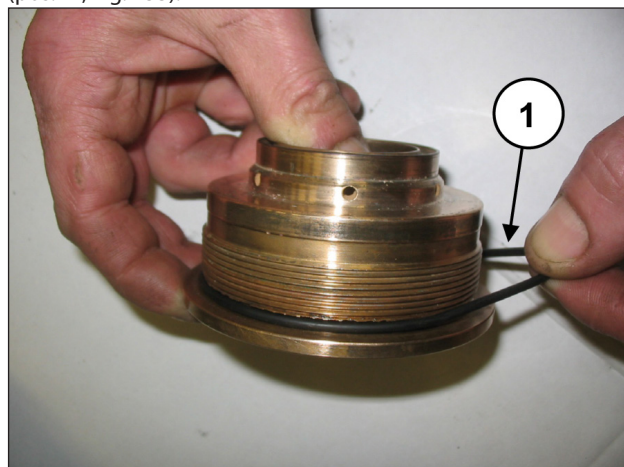

Fig. 153

Avvitare il supporto guarnizioni alla camicia (pos. ①, Fig. 154) e serrare mediante di una chiave a compasso con naselli tonde Ø5, reperibile sul mercato, (pos. ①, Fig. 155) fino a portare a battuta il supporto sulla camicia.



Fig. 154

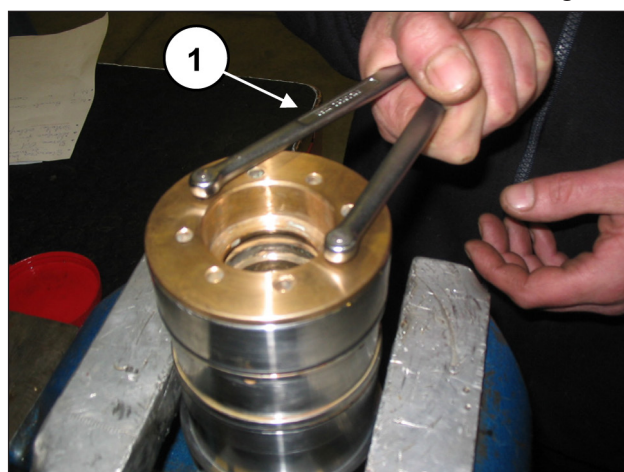

Fig. 155

Inserire la rosetta $\varnothing 10 \times 18 \times 0.9$ nella vite fissaggio pistone (pos. ①, Fig. 156).

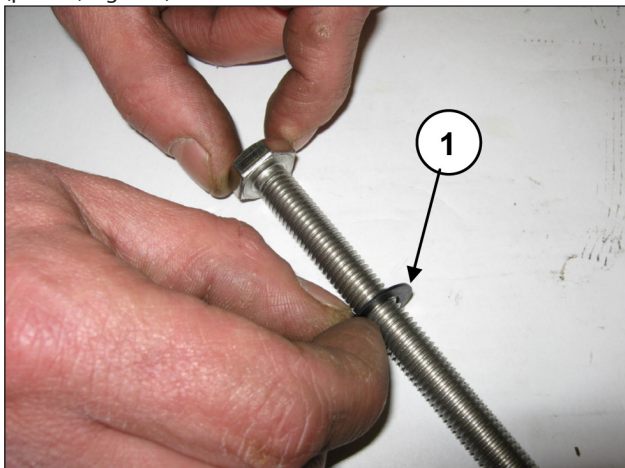

Fig. 156

Montare i pistoni sulle rispettive guide (pos. ①, Fig. 157) e fissarli come da pos. ①, Fig. 158.

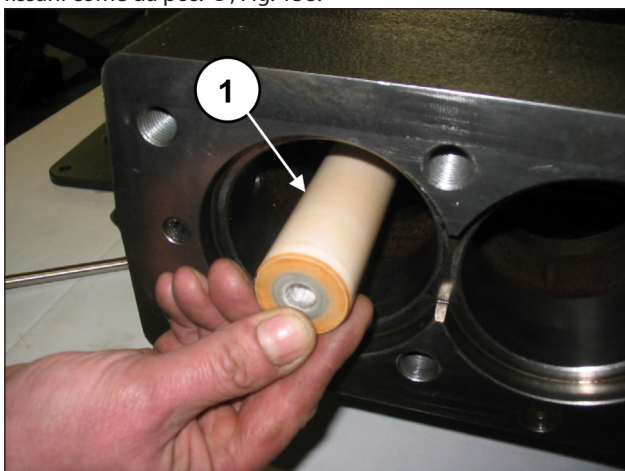

Fig. 157

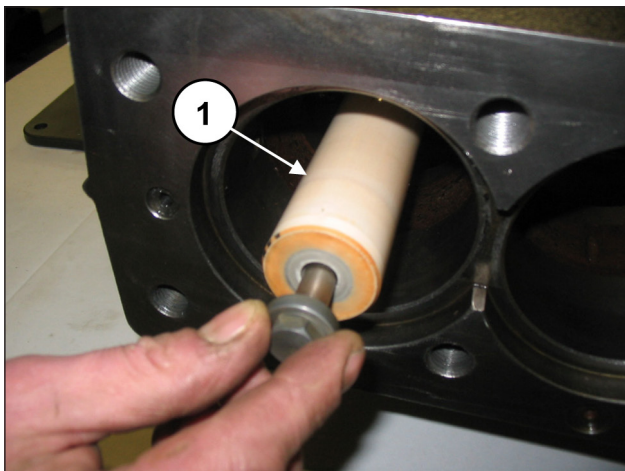

Fig. 158

Tarare le viti con chiave dinamometrica come indicato nel capitolo 3.

Inserire il blocco camicia-supporto guarnizione (completo dei due appositi O-ring) precedentemente assemblato fino a battuta (pos. ①, Fig. 159).

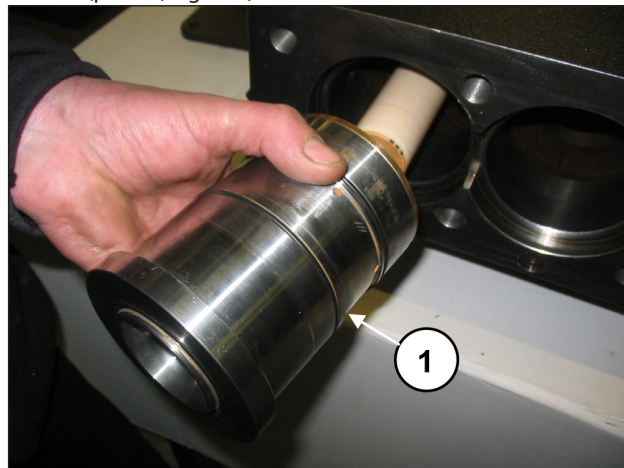

Fig. 159

Assicurarsi che il blocco camicia-supporto arrivi a posizionarsi correttamente fino a fondo sede (pos. ①, Fig. 160).

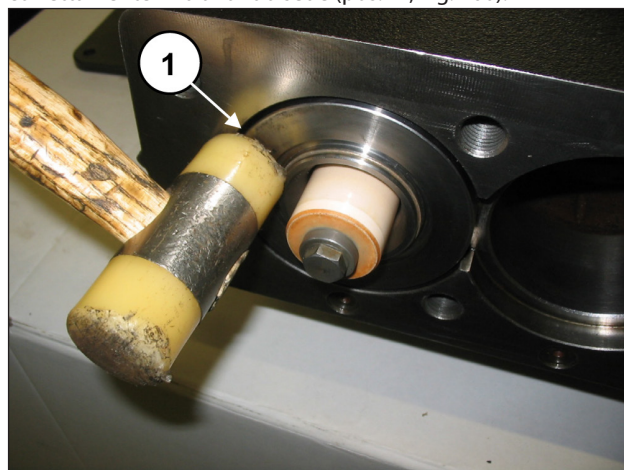

Fig. 160

Montare l'O-ring frontale della camicia (pos. ①, Fig. 161) e l'O-ring del foro di ricircolo (pos. ①, Fig. 162).

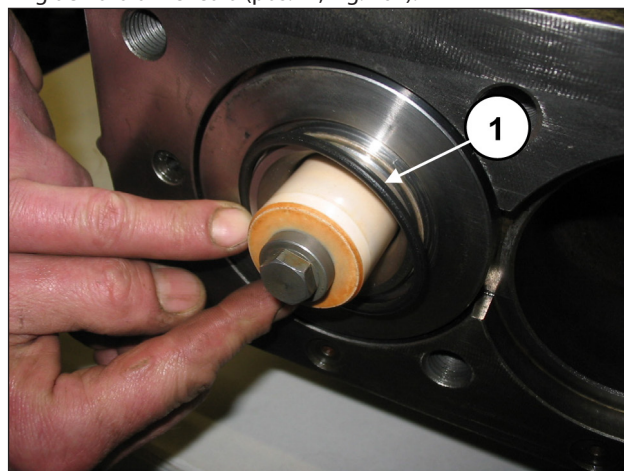

Fig. 161

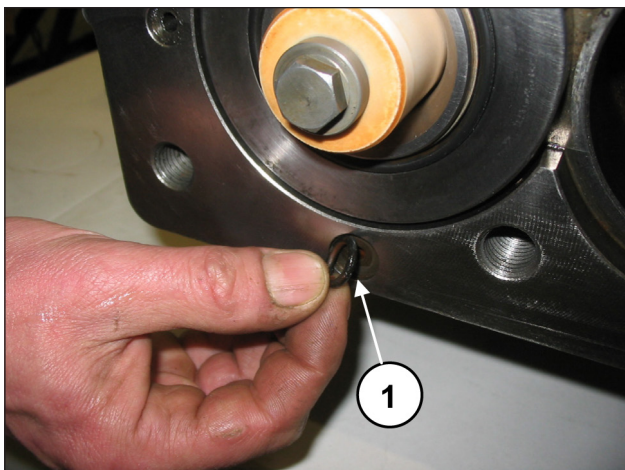

Fig. 162

Sui coperchi ispezione inserire l'O-ring (pos. ①, Fig. 163) e montare i coperchi mediante l'utilizzo di 4+4 viti M6x14 (pos. ①, Fig. 164).

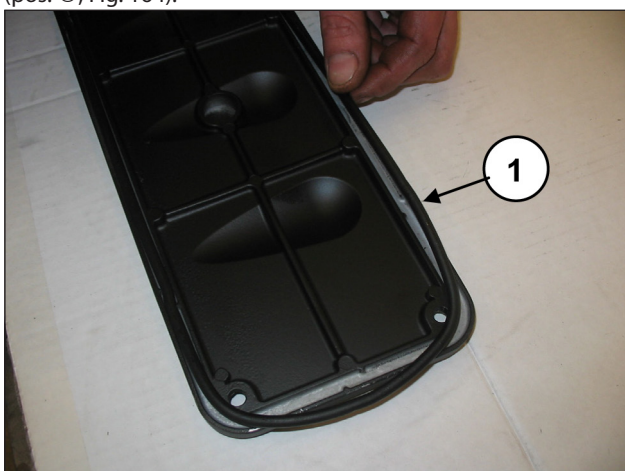

Fig. 163

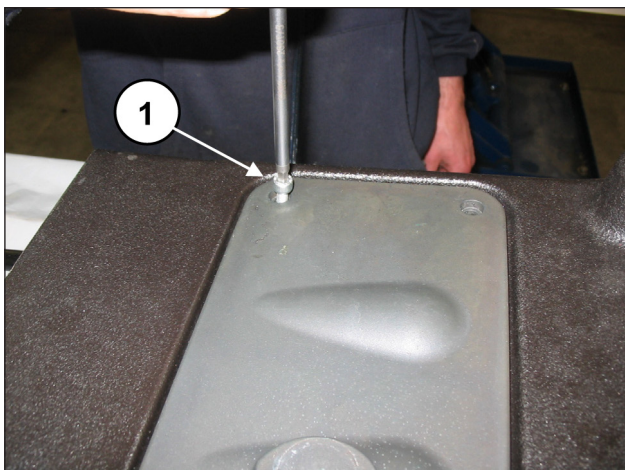

Fig. 164

Tarare le viti con chiave dinamometrica come indicato nel capitolo 3.

2.2.5 Recupero testate

Qualora la testata presentasse all'interno delle camere dei pistoni evidenti segni di cavitazione, dovuti ad una non corretta alimentazione della pompa, è possibile recuperare la testata danneggiata evitandone la sostituzione.

Per il recupero della testata eseguire le lavorazioni indicate nella Fig. 165 per LK36-40-45 e nella Fig. 166 per LK50-55-60:

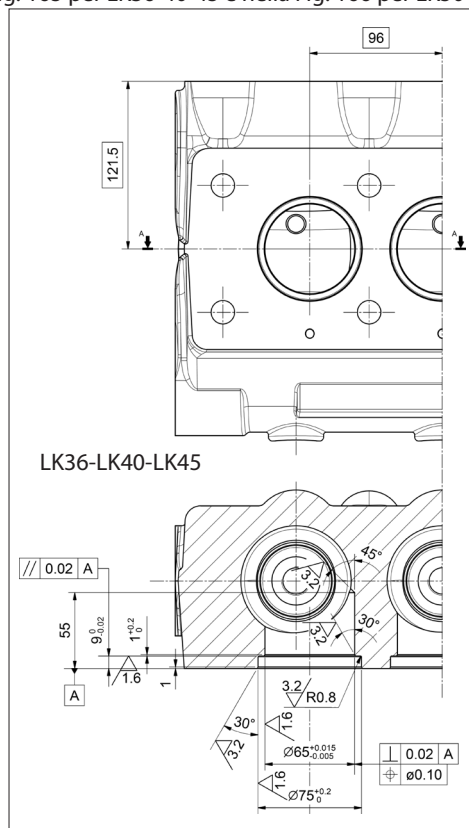

Fig. 165

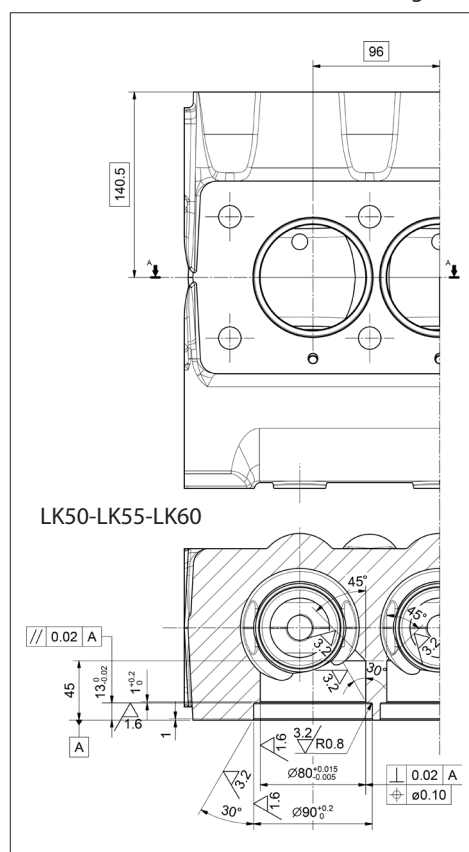

Fig. 166

La testata lavorata deve essere assemblata mediante piantaggio delle boccole (pos. ①) complete di anelli antiestrusione (pos. ②) e O-ring (pos. ③) come rappresentato in Fig. 167 per LK36-40-45 e in Fig. 168 per LK50-55-60:

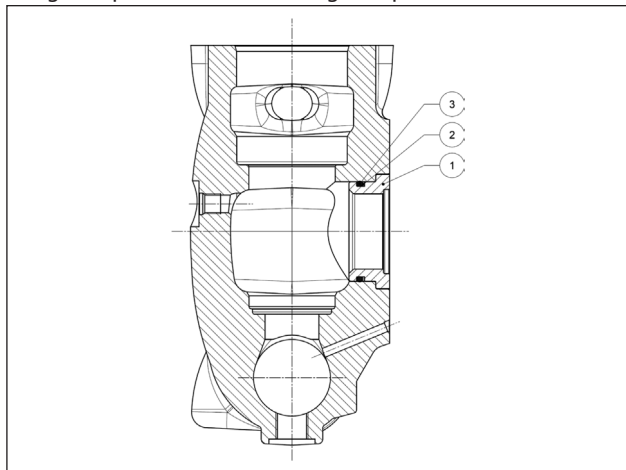

Fig. 167

n. 1 - Boccola LK36-40-45 - cod. 78216756 - q.tà 3

n. 2 - Anello antiestrusore - cod. 90526880 - q.tà 6
n. 3 - O-ring - cod. 90410200 - q.tà 6

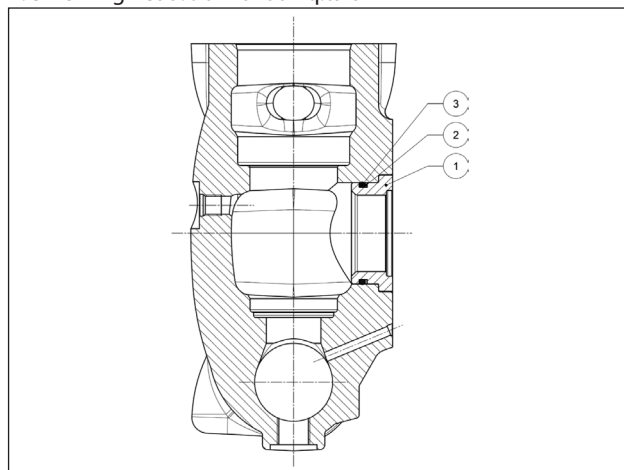

Fig. 168

n. 1 - Boccola LK50-55-60 - cod. 78216656 - q.tà 3
n. 2 - Anello antiestrusore - cod. 90528500 - q.tà 6
n. 3 - O-ring - cod. 90412900 - q.tà 6

3 TARATURE SERRAGGIO VITI

Il serraggio delle viti è da eseguirsi esclusivamente con chiave dinamometrica.

Descrizione	Posizione Esploso	Coppia Serraggio Nm
Vite M8x20 coperchio carter	54	25
Tappo G1/2x13 carter	78	40
Vite M8x30 coper. cuscinetto PTO	95	25
Vite M8x20 coper. estremità albero	54	25
Vite M10x30 coper. portacuscinetto	69	45
Vite M6x14 coperchi super. e infer.	82	10
Vite M8x20 coperchio cuscinetto	54	25
Vite M12x1.25x87 serraggio biella	52	75*
Vite M6x20 guida pistone	49	10
Vite M12x25 flangia blocc. bussola	63	68.5
Vite M10x160 fissaggio pistone	27	40
Vite M16x55 coperchio valvole	26	333
Tappo G1/4"x13 testata	13	40
Vite M16x150 testata	25	333**
Dispositivo apertura valvole	2	40

* Raggiungere la coppia di serraggio serrando le viti contemporaneamente.

** Serrare le viti partendo dalle 4 viti interne in modo incrociato (vedere Fig. 135), per poi proseguire con le 4 viti esterne, sempre serrando in modo incrociato.

4 ATTREZZI PER LA RIPARAZIONE

La manutenzione della pompa può essere eseguita tramite semplice attrezzi per lo smontaggio e il rimontaggio dei componenti. Sono disponibili i seguenti attrezzi:

Per il montaggio:

Anello di tenuta radiale guida pistone	cod. 27910900
Anello di tenuta radiale albero PTO	cod. 27539500
	cod. 27548200
O-ring sede valvola mandata LK36-LK40-LK45	cod. 27516000
O-ring sede valvola mandata LK50-LK55-LK60	cod. 27516100

Per lo smontaggio:

Sede valvola aspirazione LK36-LK40-LK45	cod. 27516200
Sede valvola aspirazione LK50-LK55-LK60	cod. 27516300
Sede valvola mandata	cod. 27516400
Blocco camicia + supporto guarnizioni	cod. 27516600
Albero (bloccaggio bielle)	cod. 27566200

5 VERSIONI SPECIALI

Di seguito vengono riportate le indicazioni relative alla riparazione delle versioni speciali. Dove non diversamente specificato attenersi a quanto riportato in precedenza per la pompa LK versione standard.

- Pompe LKN: per la riparazione valgono le indicazioni relative alla pompa LK standard.

6 SOSTITUZIONE DELLA BOCCOLA DI PIEDE BIELLA

Eeguire il piantaggio della boccola a freddo e le successive lavorazioni attenendosi alle dimensioni e tolleranze della sottostante Fig. 169.

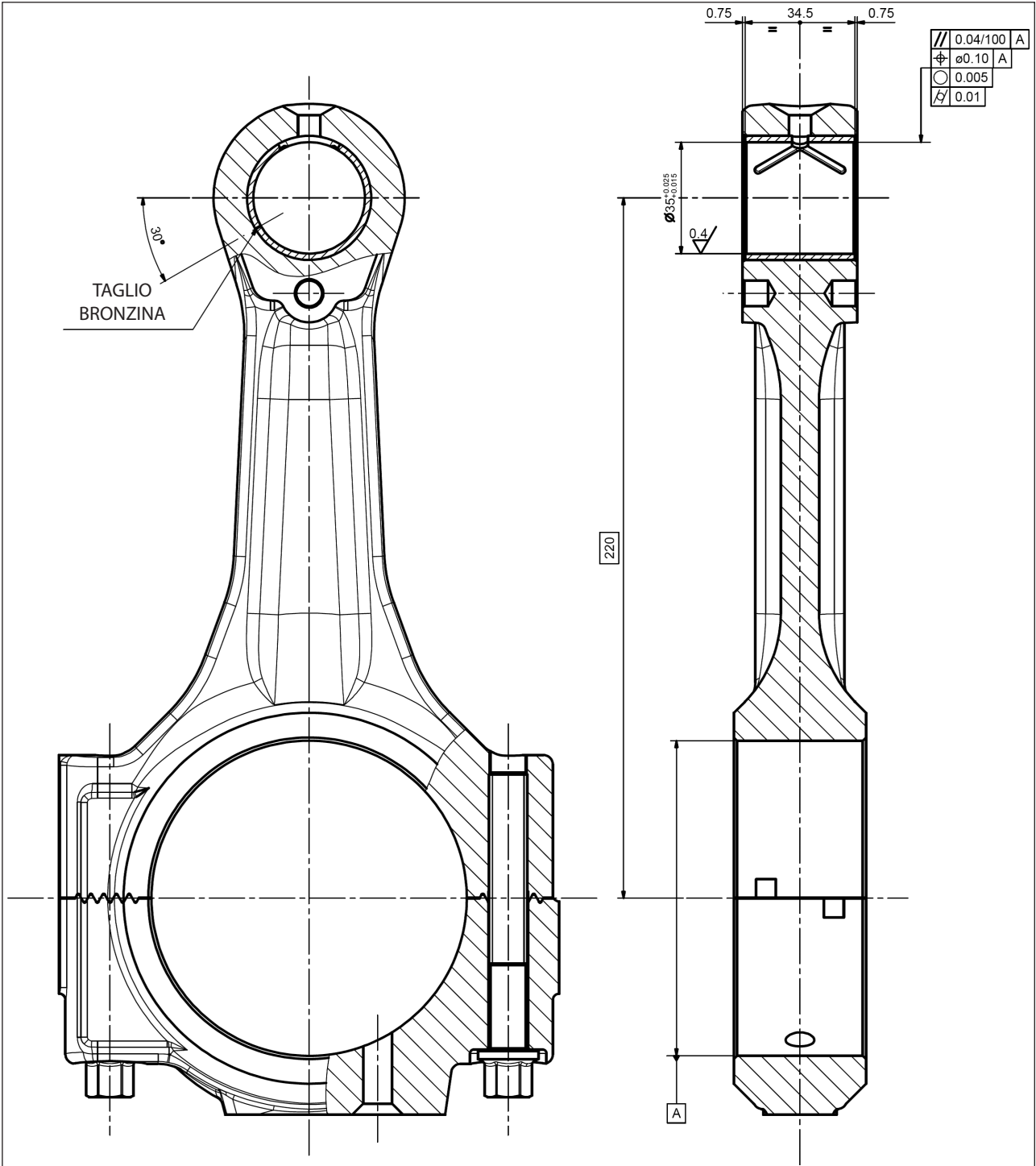

Fig. 169

Table of Contents

1	INTRODUCTION	37
1.1	DESCRIPTION OF SYMBOLS.....	37
2	REPAIR GUIDELINES	37
2.1	REPAIRING MECHANICAL PARTS.....	37
2.1.1	<i>Disassembly of mechanical parts</i>	37
2.1.2	<i>Assembly of mechanical parts</i>	45
2.1.3	<i>Classes of increase</i>	55
2.2	REPAIRING HYDRAULIC PARTS.....	55
2.2.1	<i>Dismantling the head – valve units</i>	55
2.2.2	<i>Assembling the head – valve units</i>	57
2.2.3	<i>Disassembly of the piston unit – supports – seals</i>	61
2.2.4	<i>Assembling the piston unit – supports – seals</i>	63
2.2.5	<i>Recovering the heads</i>	66
3	SCREW TIGHTENING CALIBRATION	67
4	REPAIR TOOLS	68
5	SPECIAL VERSIONS	68
6	REPLACING THE CON-ROD FOOT BUSH	69

1 INTRODUCTION

This manual describes the instructions for repairing LK series pumps and should be carefully read and understood before any intervention on the pump. Proper pump operation and duration depend on the correct use and maintenance.

Interpump Group disclaims any responsibility for damage caused by negligence or failure to observe the standards described in this manual.

1.1 DESCRIPTION OF SYMBOLS

Read the contents of this manual carefully before each operation.



Warning Sign



Read the contents of this manual carefully before each operation.



Danger Sign

Wear protective goggles.



Danger Sign

Put on protective gloves before each operation.

2 REPAIR GUIDELINES



2.1 REPAIRING MECHANICAL PARTS

Mechanical parts must be repaired after the oil has been removed from the casing.

To remove oil, you must remove the oil filler cap pos. ①, Fig. 1 and then the drain plug pos. ②, Fig. 1.

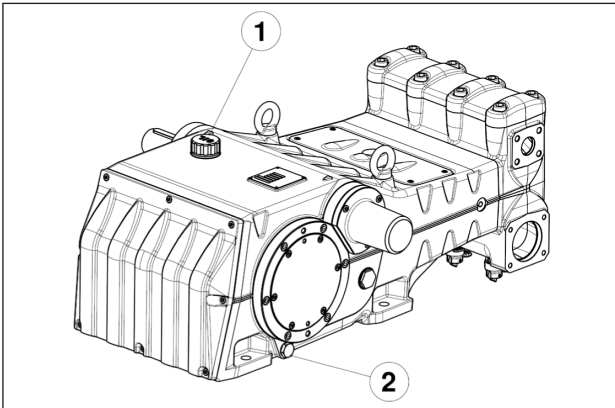

Fig. 1



The used oil must be placed in a suitable container and disposed of in special centres. It absolutely should not be discarded into the environment.

2.1.1 Disassembly of mechanical parts

The correct sequence is as follows:

Completely empty the pump of oil, as indicated in par. 2.1. Remove the valve lifters from the head and the head from the pump casing as shown in par. 2.2.1 (from Fig. 103 to Fig. 105). Detach the upper inspection cover and the lower inspection cover by unscrewing the 4+4 attachment screws, as shown in par. 2.2.3 (Fig. 139 and Fig. 140).

Remove the O-rings and replace them if necessary. Remove the three pistons and the liner/gasket support assemblies, as shown in par. 2.2.3 (Fig. 138, Fig. 141 and Fig. 142).

Remove the three spray-guard spacer rings and the spray-guards, as shown in par. 2.2.3 (Fig. 143 and Fig. 144).

Unscrew the M6 locking grub screws of the three oil seal covers (pos. ①, Fig. 2).

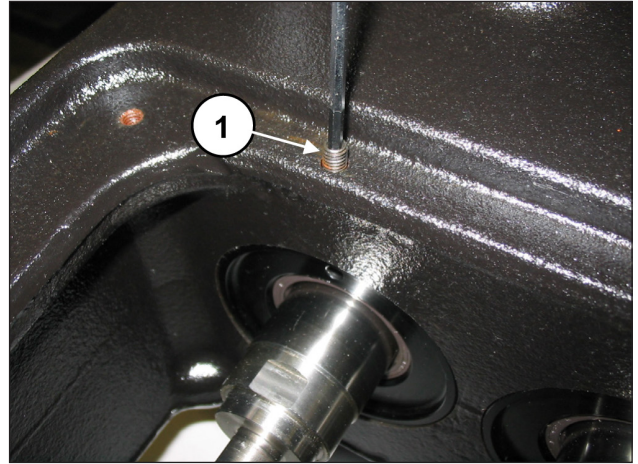

Fig. 2

Screw in a threaded bar or an extractor M6 screw in the holes in the oil seal covers (pos. ①, Fig. 3) and remove the covers from the pump assembly (pos. ①, Fig. 4).

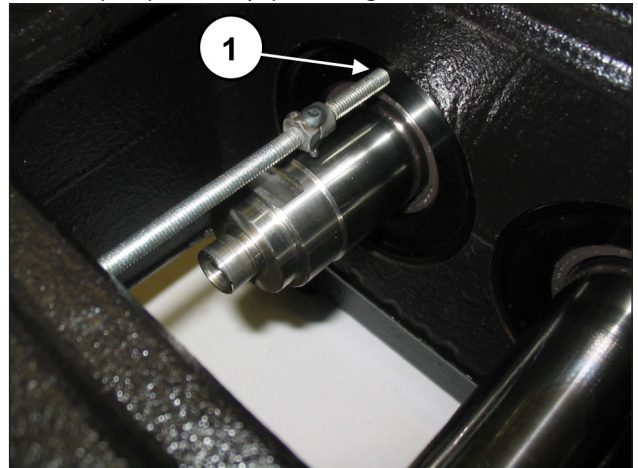

Fig. 3

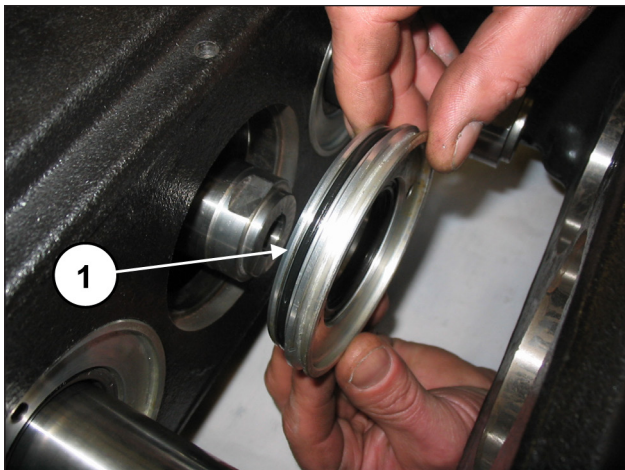

Fig. 4

Take out the radial seal ring (pos. ①, Fig. 5) and the outside O-ring (pos. ①, Fig. 6).

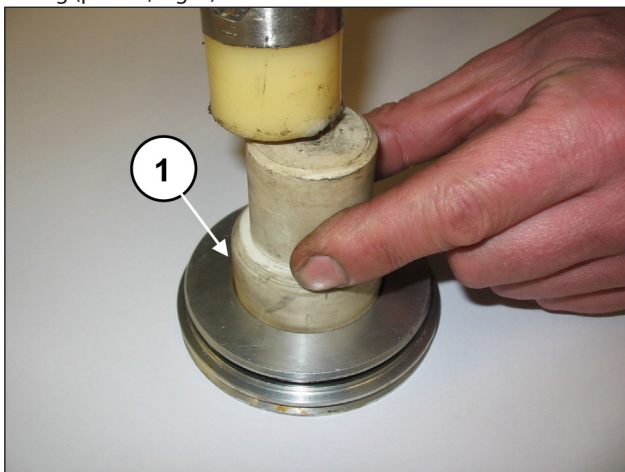

Fig. 5

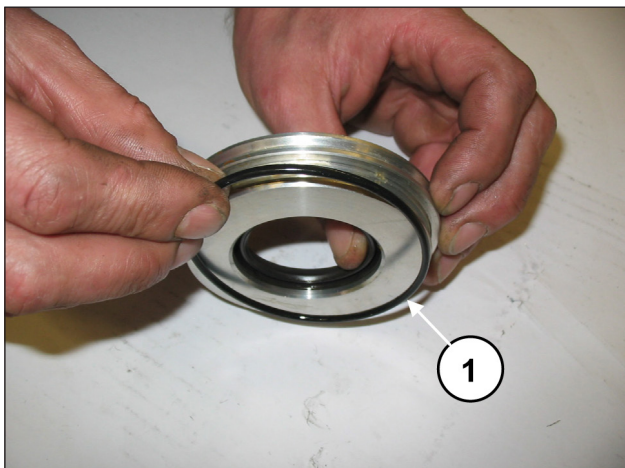

Fig. 6

Remove the tab from the PTO shaft (pos. ①, Fig. 7).

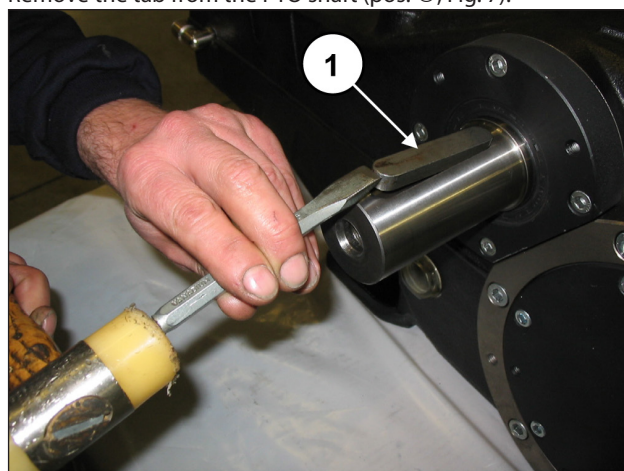

Fig. 7

Unscrew the attachment screws of the shaft end cover (pos. ①, Fig. 8) and take the cover off the PTO shaft.

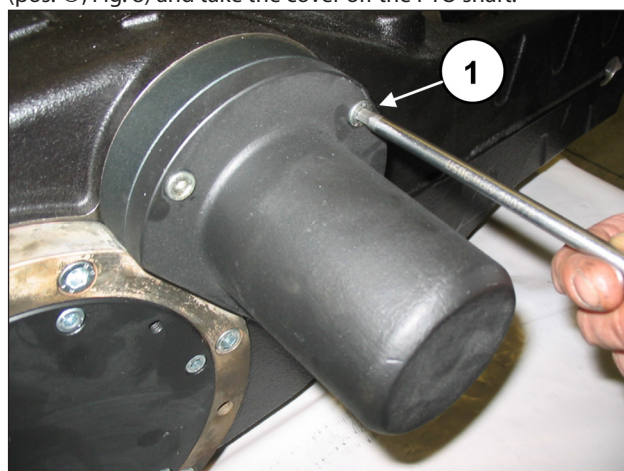

Fig. 8

Unscrew the casing cover attachment screws (pos. ①, Fig. 9) and remove it. Remove the O-ring and replace it if necessary.



Fig. 9

Now remove the two bearing covers by unscrewing the screws (pos. ①, Fig. 10).
To help with their removal, use 2 x M8 grub screws or screws (pos. ①, Fig. 11) as extractors.
Remove the O-ring and replace it if necessary.

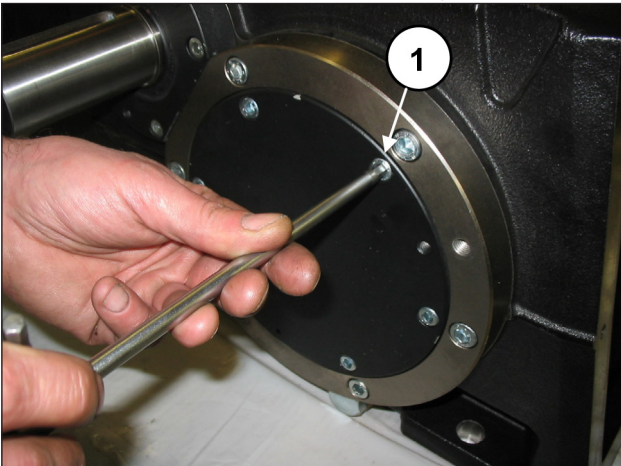

Fig. 10

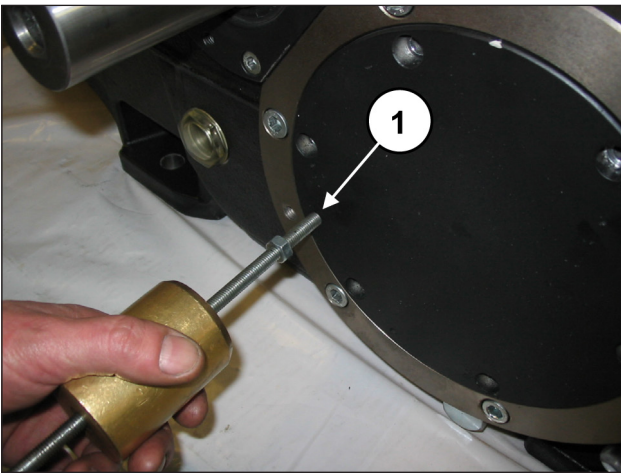

Fig. 11

Insert a shim under the shank of the central connecting rod, to stop the rotation of the bend shaft (pos. ①, Fig. 12).

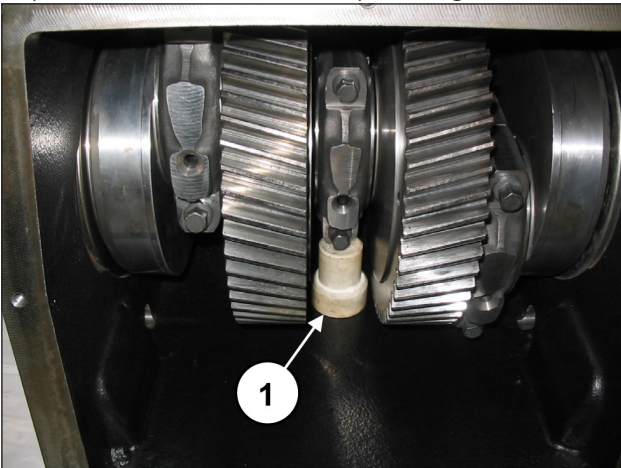

Fig. 12

Unscrew and take out the bush locking flange attachment screws, from both sides (pos. ①, Fig. 13).
The bush locking flanges must be left in position (pos. ①, Fig. 14).

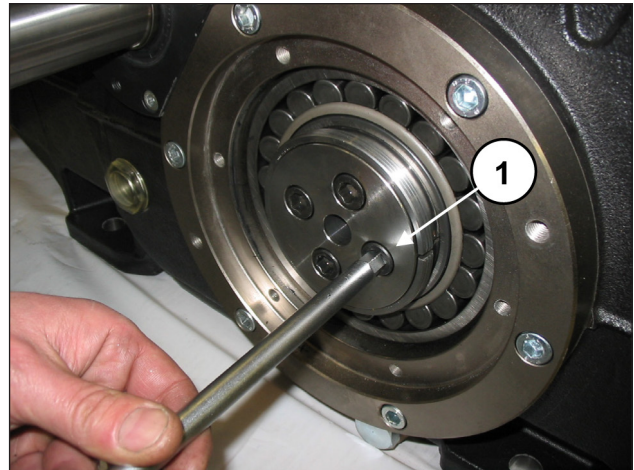

Fig. 13

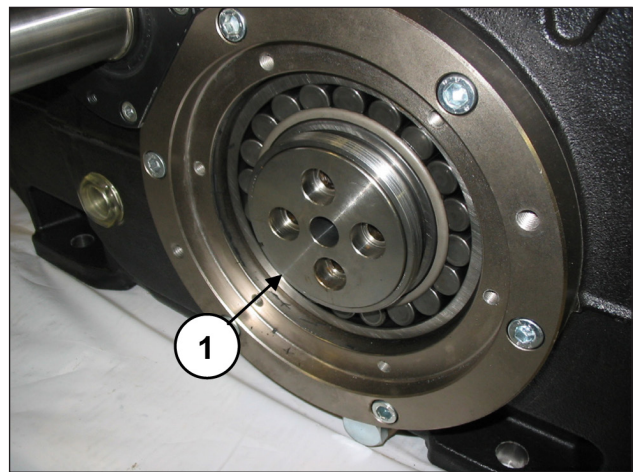

Fig. 14

On one side, screw a ring nut, type SKF KM20, onto the pressure bush (pos. ①, Fig. 15), and then unblock the bush using an extractor hammer (pos. ①, Fig. 16), but do not remove it.

Repeat the operation on the other side.

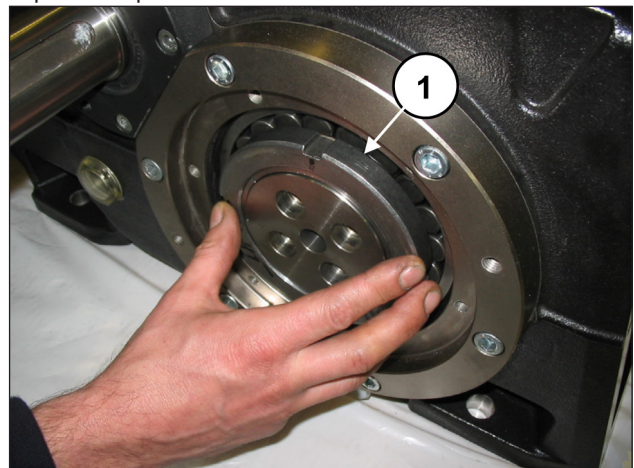

Fig. 15

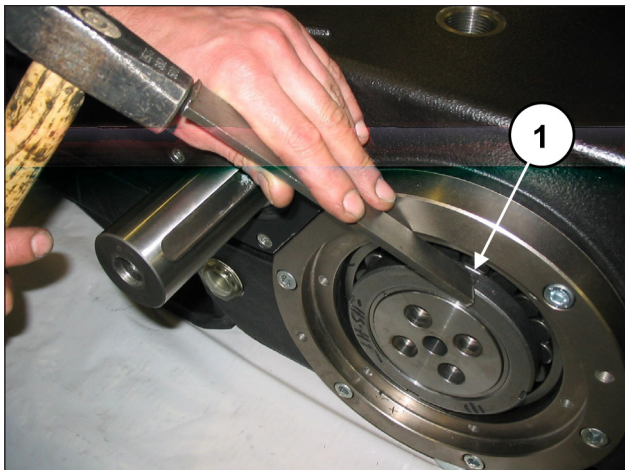

Fig. 16

Remove the shim from under the shank of the central connecting rod.
Unscrew the con-rod screws (pos. ①, Fig. 17).

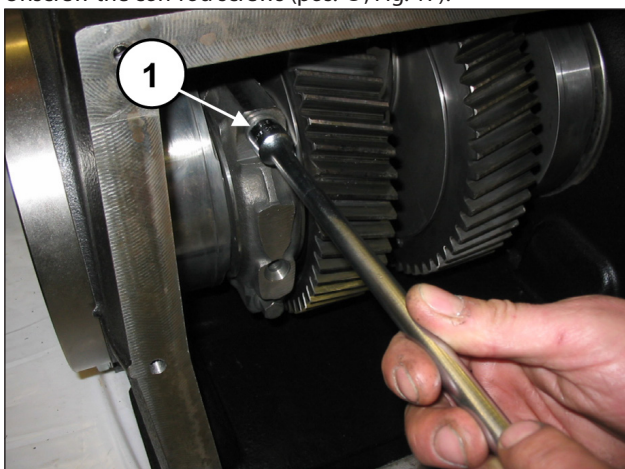

Fig. 17

Remove the con-rod caps with the semi-bearings, taking special care of the disassembly sequence during disassembly.



The con-rod caps and their relative half supports must be reassembled in exactly the same order and coupling with which they were disassembled.

To avoid possible errors, caps and half supports have been numbered on one side (pos. ①, Fig. 18).

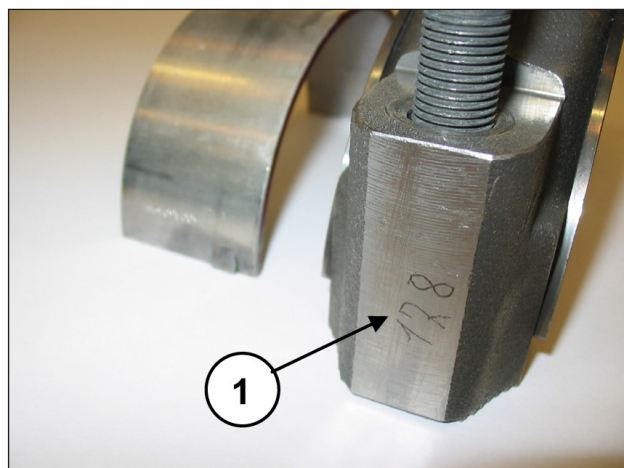

Fig. 18

Advance the three half supports as far as possible in the direction of the head.
Remove the three upper half-bearings of the half supports (pos. ①, Fig. 19).

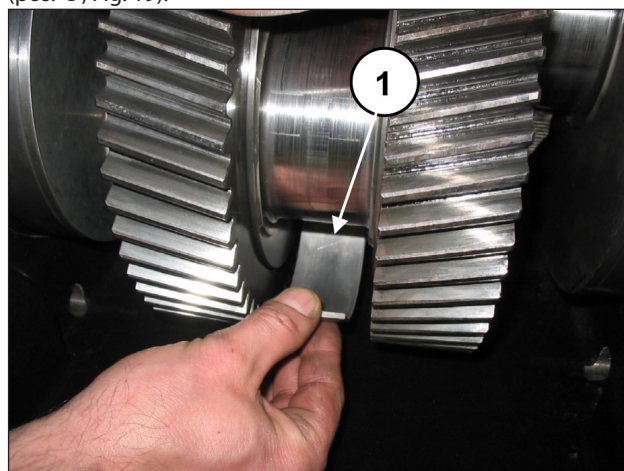

Fig. 19

Remove both pressure bushes (pos. ①, Fig. 20).

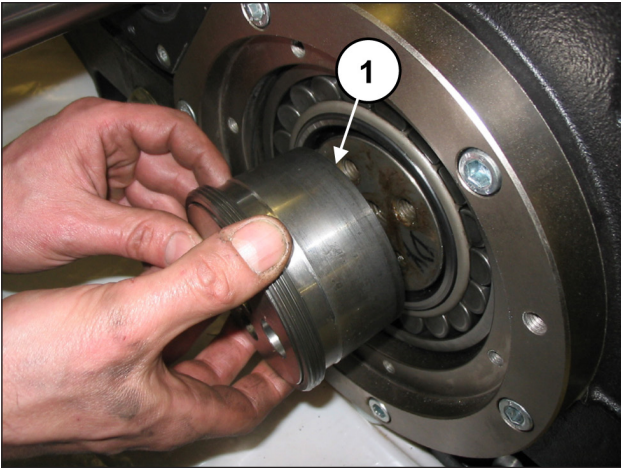

Fig. 20

Separate the bush locking flange from the pressure bush (pos. ①, Fig. 21).

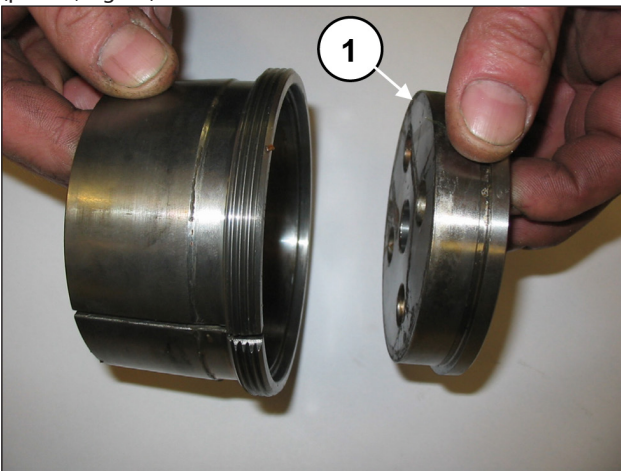

Fig. 21

Unscrew the screws of the two bearing support covers (pos. ①, Fig. 22).

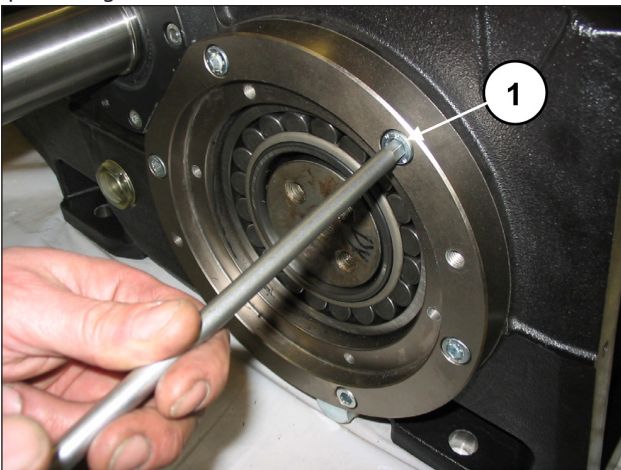

Fig. 22

Apply an M16 threaded pin to one end of the bend shaft (pos. ①, Fig. 23) and, while keeping it raised, take out the bearing support cover complete with bearing and O-ring (pos. ②, Fig. 24). To help with their removal, use 2 x M10 grub screws or screws (pos. ②, Fig. 23) as extractors. Repeat the operation on the other side.

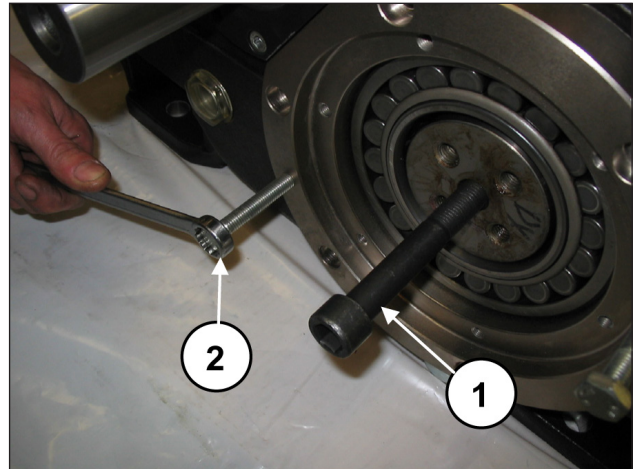

Fig. 23

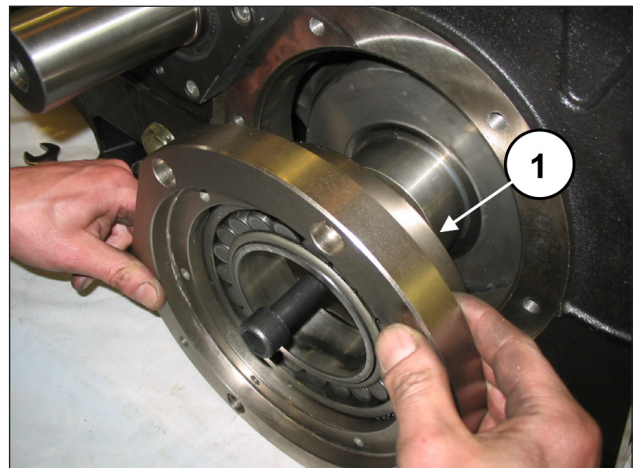

Fig. 24

Lay the bend shaft on the bottom of the casing. Separate the bearing support cover from the bearing, using an extractor hammer (pos. ①, Fig. 25).

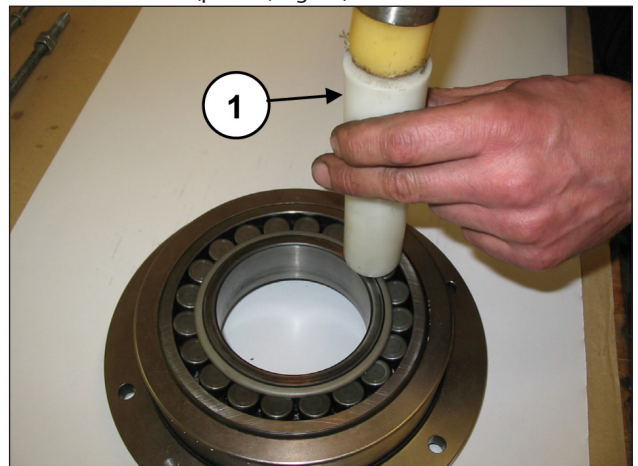

Fig. 25

Unscrew the attachment screws of the left and right PTO bearing cover (pos. ①, Fig. 26) and take the two covers off the PTO shaft. To help with their removal, use 3 x M8 grub screws or screws (pos. ①, Fig. 27) as extractors.

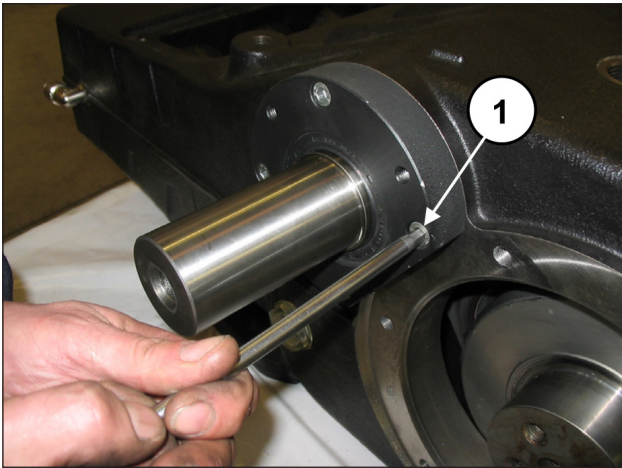

Fig. 26

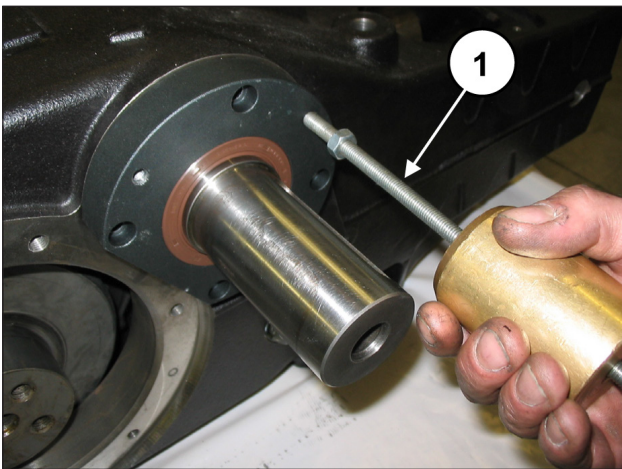

Fig. 27

Take out the radial seal ring (pos. ①, Fig. 28), the outside O-ring (pos. ①, Fig. 29) and the lubrication hole O-ring (pos. ①, Fig. 30).

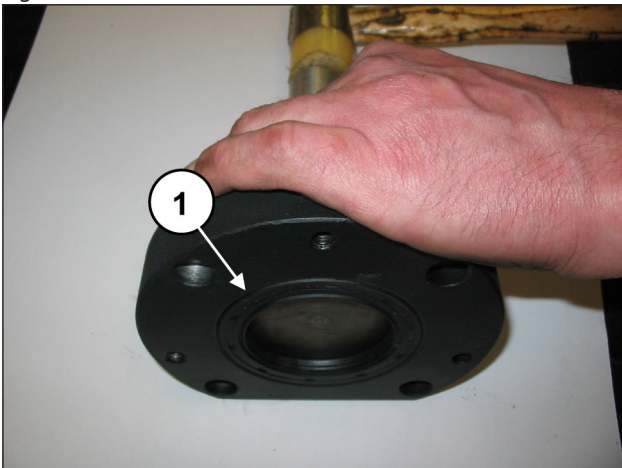

Fig. 28

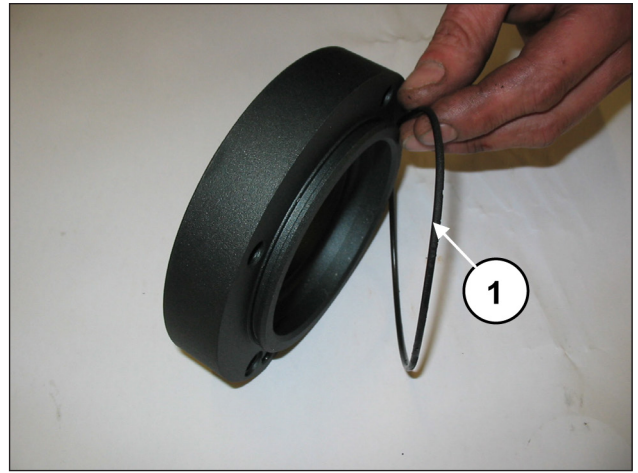

Fig. 29

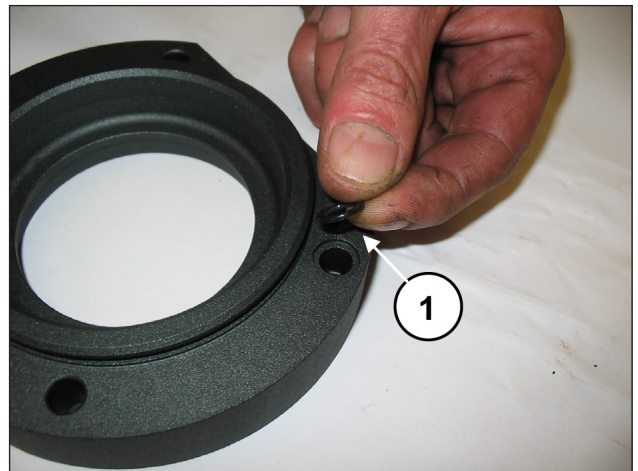

Fig. 30

Roll back the three connecting rods as far as possible (until they touch the bend shaft).

Using an extractor hammer (pos. ①, Fig. 31) take out the PTO shaft from either one of the two sides (pos. ①, Fig. 32).

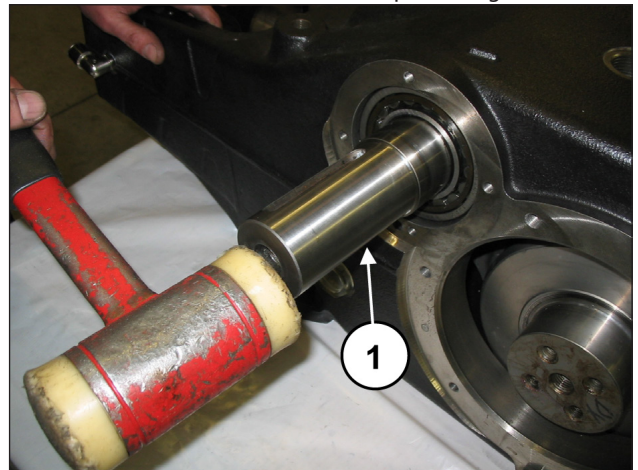

Fig. 31

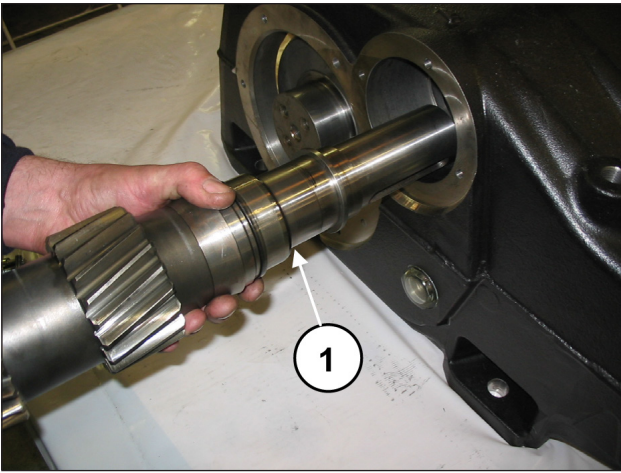

Fig. 32

Remove the internal bearing rings from the PTO shaft (pos. ①, Fig. 33) and also take out the two internal bearing spacers (pos. ②, Fig. 33).

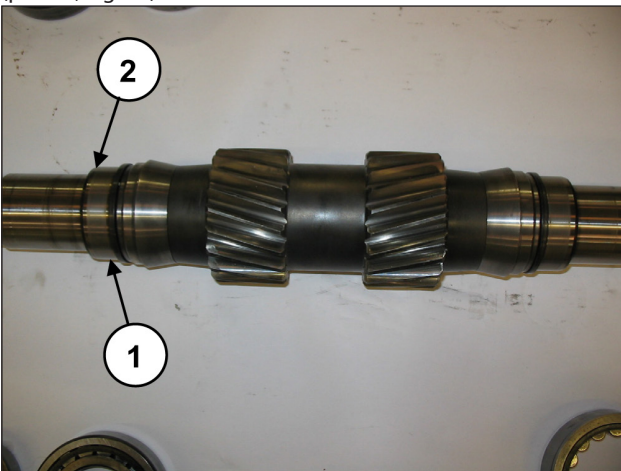

Fig. 33



The internal and external bearing rings must be reassembled in exactly the same order and pairings in which they were dismantled.

Using a sufficiently long bar (pos. ①, Fig. 34) and an extractor hammer, take the bearing rings out of the pump casing (pos. ①, Fig. 35), along with the external bearing spacer (pos. ①, Fig. 36) and the bearing lubrication bush (pos. ①, Fig. 37).

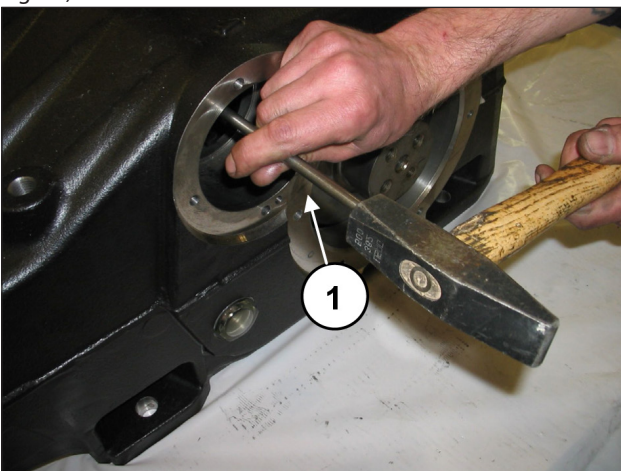

Fig. 34

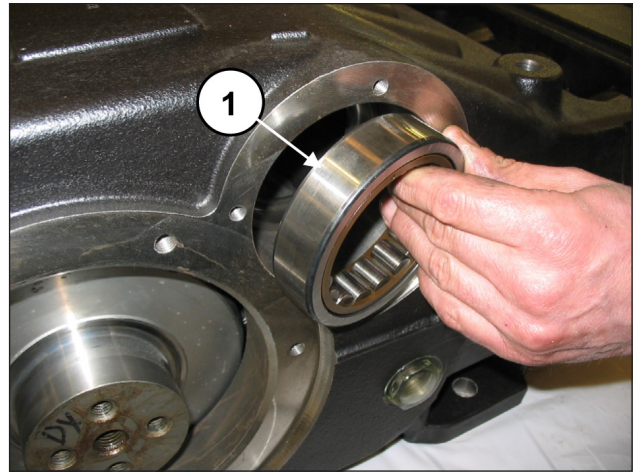

Fig. 35

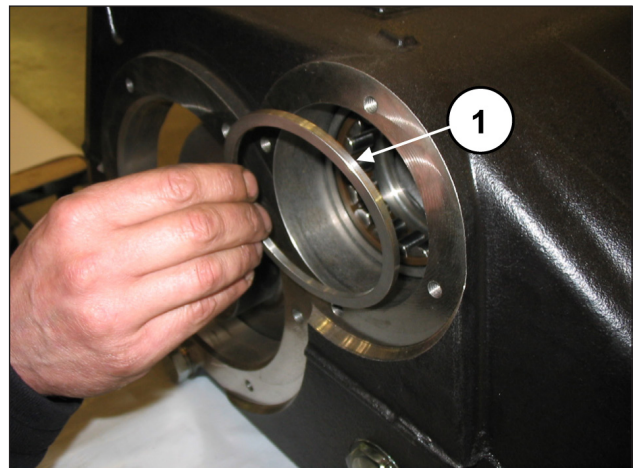

Fig. 36

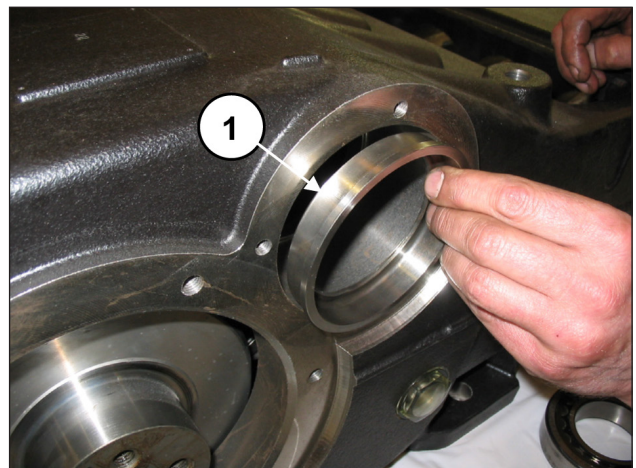

Fig. 37

Advance the half supports in the direction of the hydraulic part and lock them in place using the special tool (code 27566200) (pos. ①, Fig. 38).

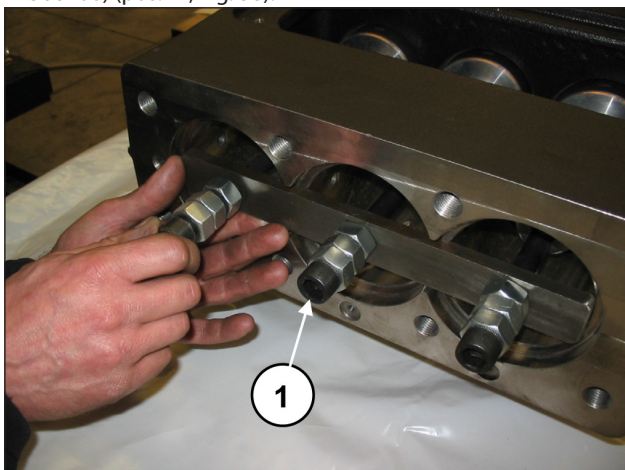

Fig. 38

Remove the bend shaft from the back of the casing (pos. ① pos. ①, Fig. 39).

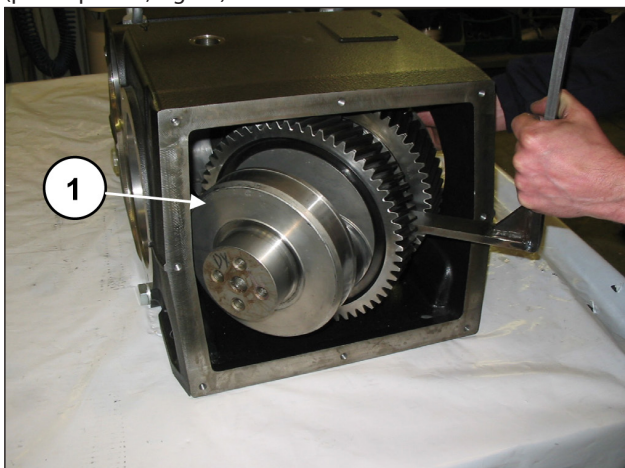

Fig. 39

Unscrew the screws with tool code 27566200 to unlock the con-rods (pos. ①, Fig. 40) and then extract the con-rod-piston guide units from the back casing opening (pos. ①, Fig. 41).

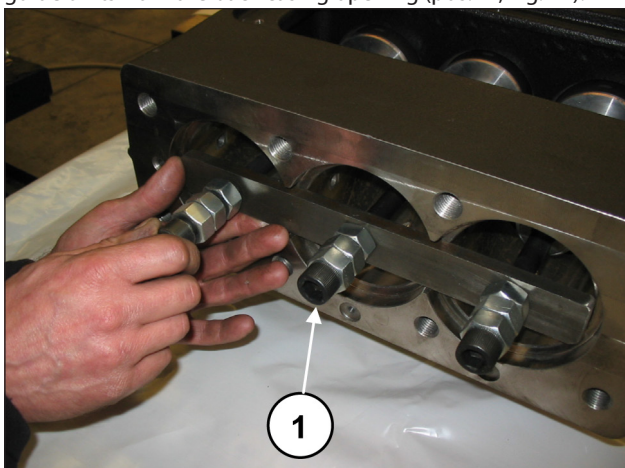

Fig. 40

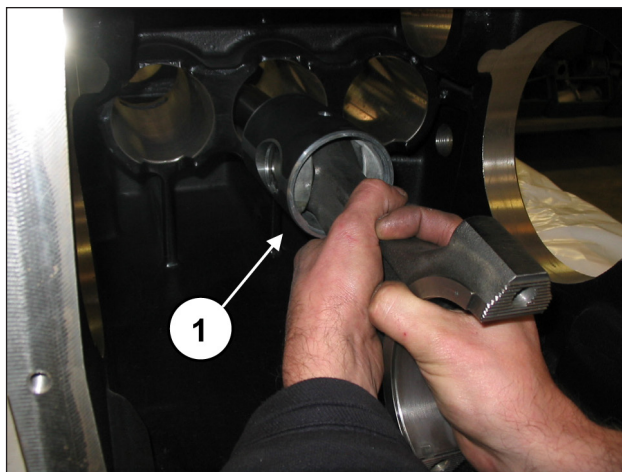

Fig. 41

Couple the half supports to the previously disassembled caps, referring to the numbering (pos. ①, Fig. 42).

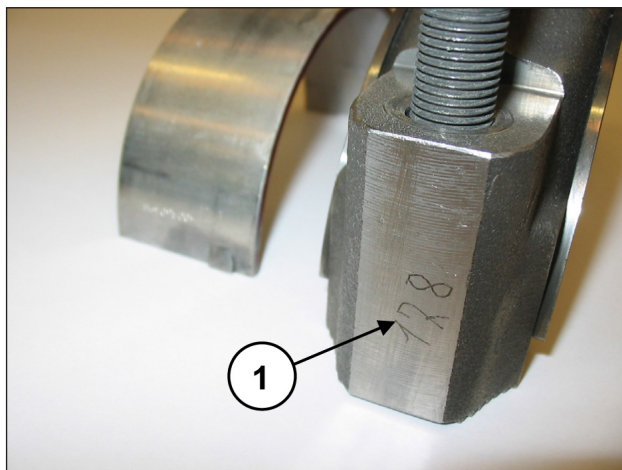
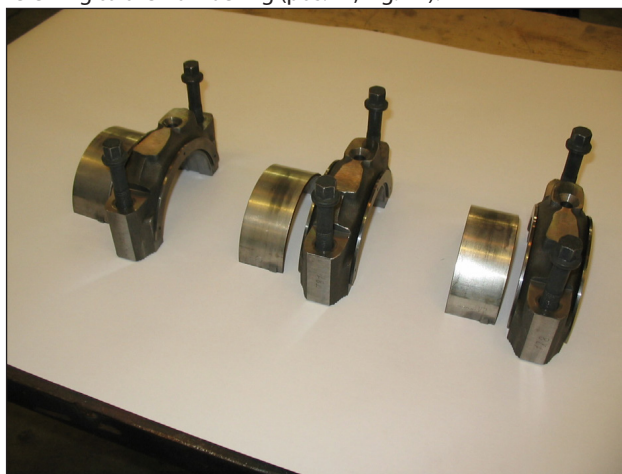

Fig. 42

Remove the two spindle locking Seeger rings using a special tool (pos. ①, Fig. 43).

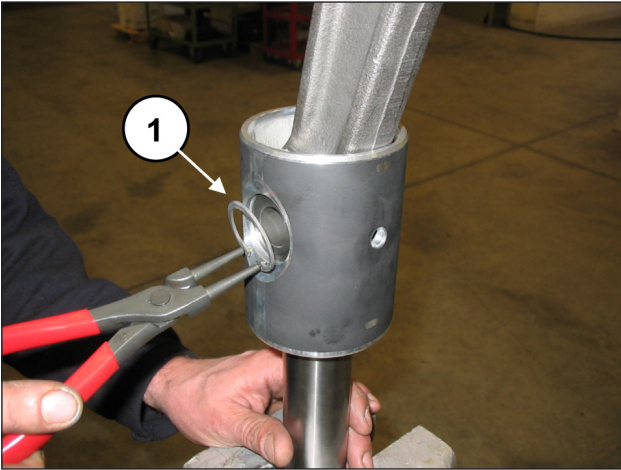

Fig. 43

Remove the spindle (pos. ①, Fig. 44) and extract the con-rod (pos. ①, Fig. 45).

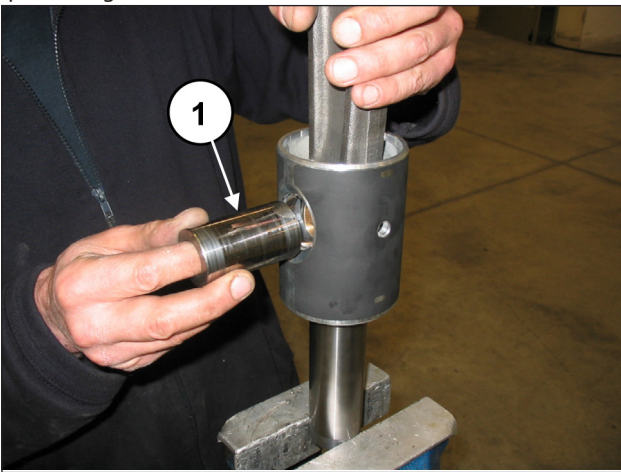

Fig. 44

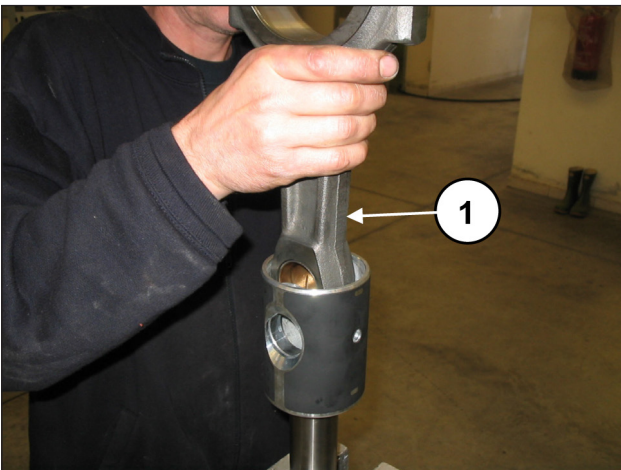

Fig. 45

To separate the rod from the piston guide, unscrew the hexagonal head M6 screws with a special wrench (pos. ①, Fig. 46).

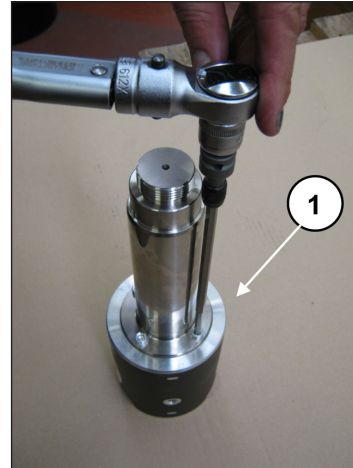

Fig. 46

Complete the disassembly of the mechanical part by removing the oil level indicators and the eyebolts.

2.1.2 Assembly of mechanical parts

Proceed with assembly following the reverse order indicated in par. 2.1.1.

The correct sequence is as follows:

Attach the two oil level indicators, the two oil drain plugs and the 90° quick coupler (pos. ①, ② and ③ Fig. 47).

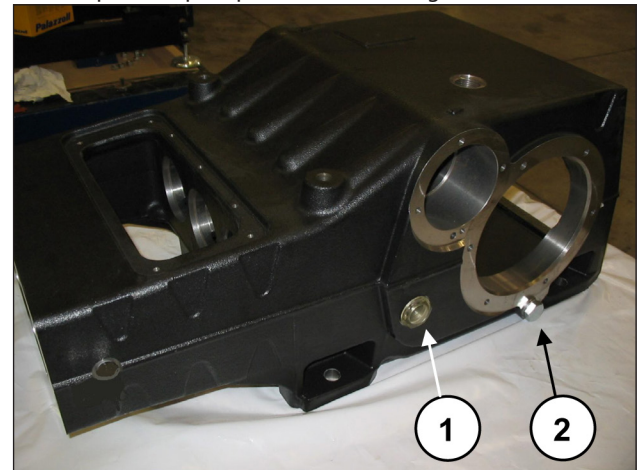

Fig. 47

Assemble the red to the piston guide.

Insert the piston guide rod into its seat on the piston guide (pos. ①, Fig. 48) and join the rod to the piston guide by means of the 4 M6x20 screws (pos. ①, Fig. 49).



Fig. 48



Fig. 49

Lock the piston guide in a vice with the aid of a special tool and calibrate the screws with a torque wrench (pos. ①, Fig. 50) as indicated in chapter 3.

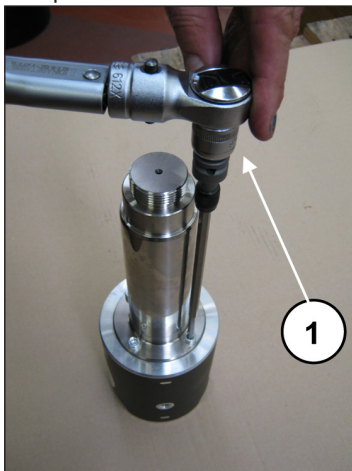

Fig. 50

Insert the con-rod in the piston guide (pos. ①, Fig. 45) and then insert the spindle (pos. ①, Fig. 44). Fit on the two Seeger rings with the special tool (pos. ①, Fig. 43).



Assembly has been carried out properly if the con-rod foot, piston guide and spindle rotate freely.

Separate the caps from the half supports. Proper coupling can be verified by the numbering on the side (pos. ①, Fig. 42). After having checked casing cleaning, proceed with assembly of half support-piston guide unit inside casing rods (pos. ①, Fig. 41).



Insertion of the half support-piston guide unit in the casing must be made with the half bearings set in the direction in which numbers are visible from above.

Block the three units with the use of special tool code 27566200 (pos. ①, Fig. 40).

Insert the bend shaft through the rear opening of the casing and lay it on the bottom.



The bend shaft must be inserted into the casing so that the teeth on the ring gears are oriented as shown in Fig. 51.

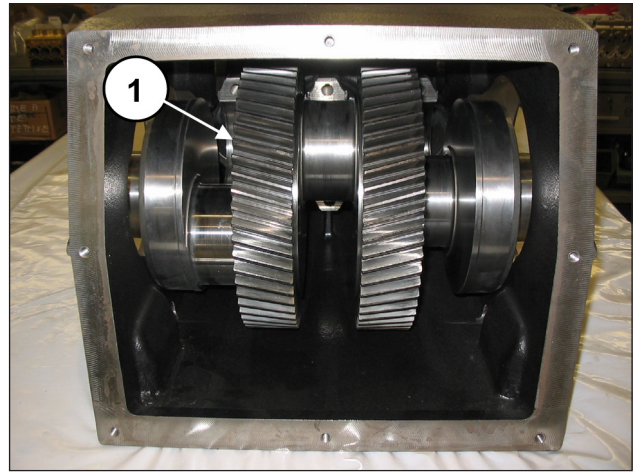

Fig. 51

Pre-assemble the PTO shaft:

Onto the PTO shaft, slip on the 2 internal rings of the bearings (one per side) (pos. ①, Fig. 52).

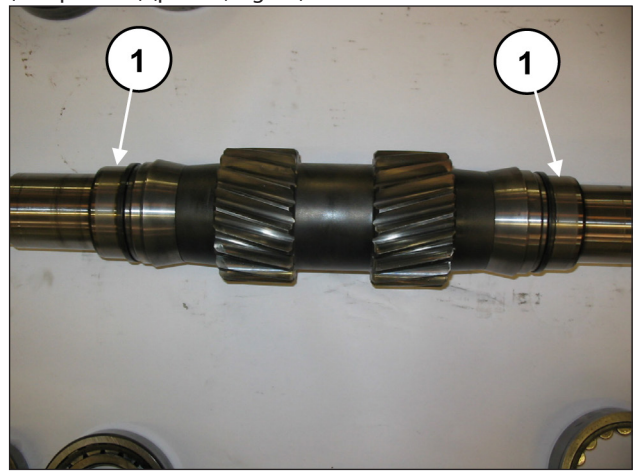

Fig. 52



The internal and external bearing rings must be reassembled in exactly the same order and pairings in which they were dismantled.

From one side of the casing, insert the bearing lubrication bush (pos. ①, Fig. 53) and an external bearing ring (pos. ①, Fig. 54) using a buffer and an extractor hammer.

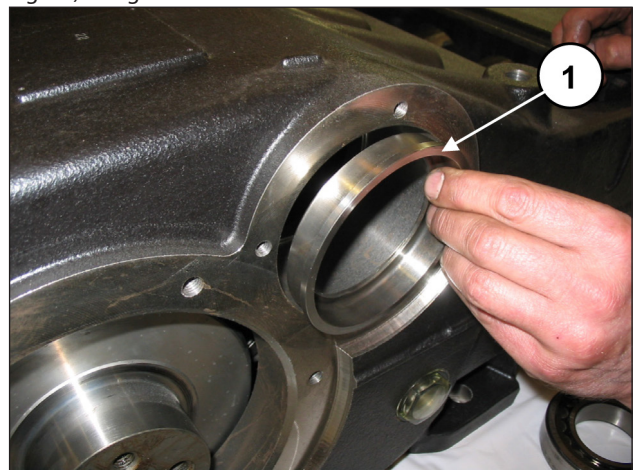

Fig. 53

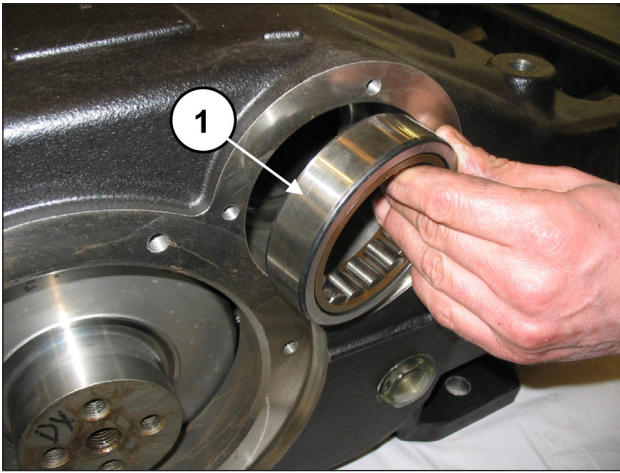

Fig. 54

Remove the tool for blocking the con-rods code 27566200 (pos. ①, Fig. 40) and roll back the connecting rods until they touch the bend shaft.

Insert the pre-assembled PTO shaft into the casing (pos. ①, Fig. 55). Insert it from the other side to the side where the external bearing ring and the bearing lubrication bush were inserted.



The PTO shaft must be inserted into the casing so that the teeth are oriented as shown in Fig. 55.

It is easier to insert the PTO shaft completely inside the bearing by applying an M16 screw to the end of the shaft being inserted, to keep the shaft lifted up (pos. ①, Fig. 56).

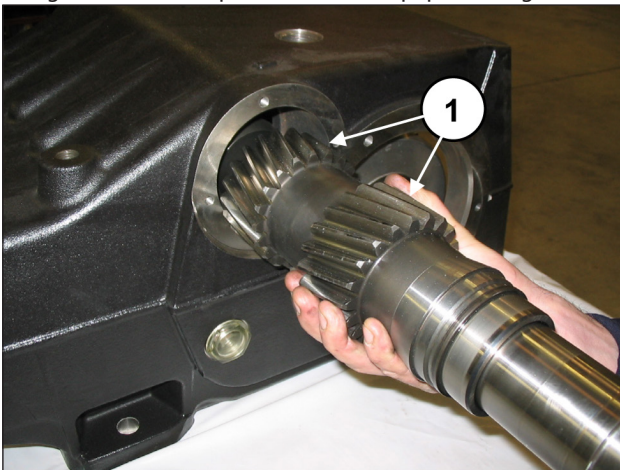

Fig. 55

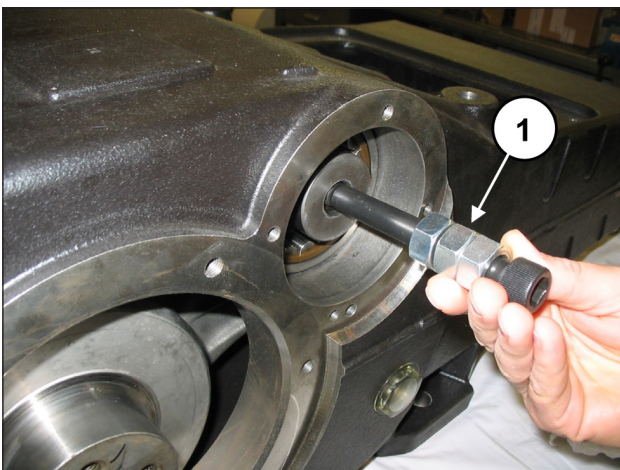

Fig. 56

From the side of the casing where the PTO shaft was inserted, proceed to insert the bearing lubrication bush (pos. ①, Fig. 57) and an external bearing ring (pos. ①, Fig. 58) using a buffer and an extractor hammer.



Fig. 57

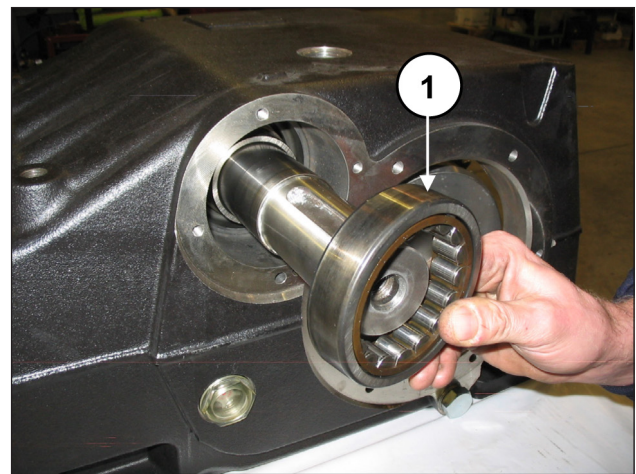

Fig. 58

At both sides, insert the internal bearing spacers (pos. ①, Fig. 59) and the external bearing spacers (pos. ①, Fig. 60).

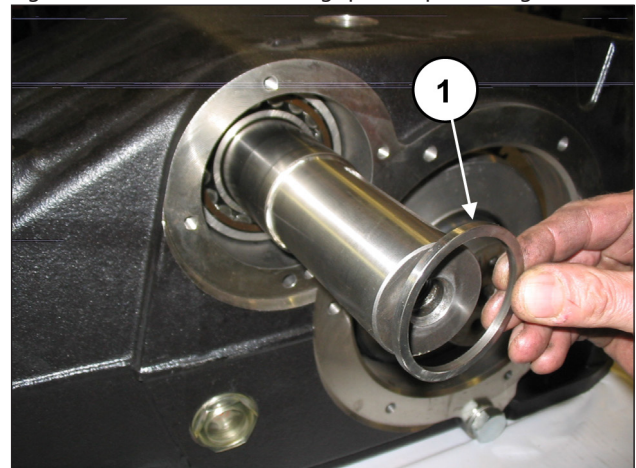

Fig. 59

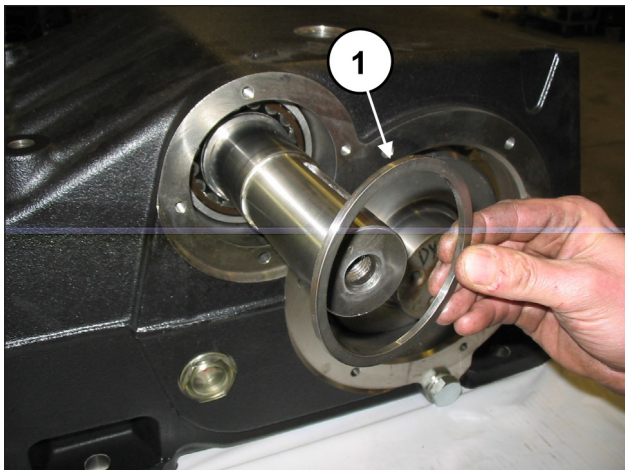

Fig. 60

Insert the internal ring (pos. ①, Fig. 61) and external ring (pos. ①, Fig. 62) of a bearing from one side of the pump only.

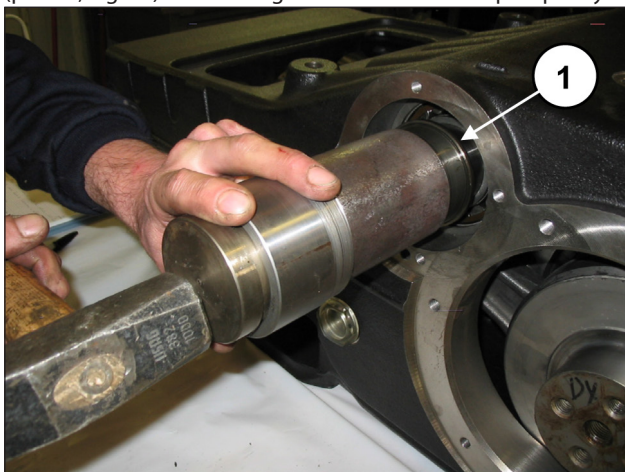

Fig. 61

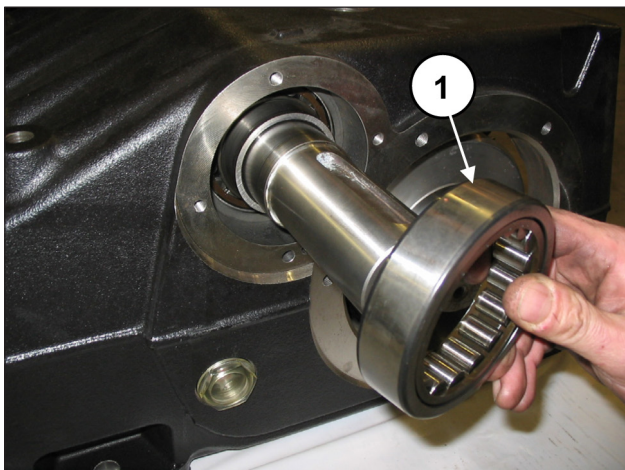

Fig. 62

Pre-assemble the left and right PTO bearing covers:
 Insert the radial seal ring into the PTO bearing cover using the tool code 27539500 (pos. ①, Fig. 63).
 Before proceeding with the assembly of the radial seal ring, verify the condition of the seal lip. If it is necessary to replace it, position the new ring as shown in Fig. 64.



If the PTO shaft shows diameter wear corresponding to the seal lip, then to avoid grinding you can position the ring as a second step as shown in Fig. 64.

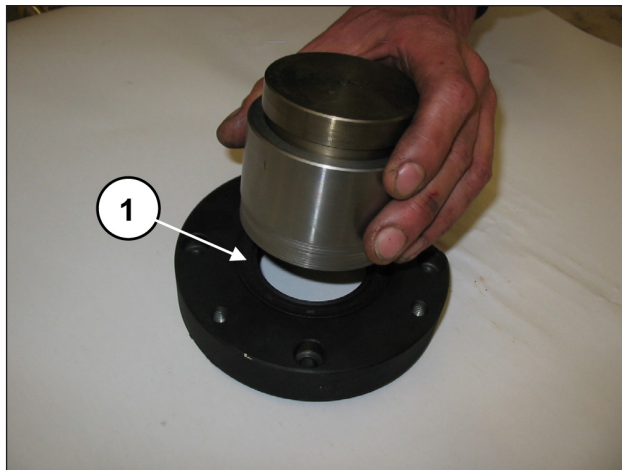

Fig. 63

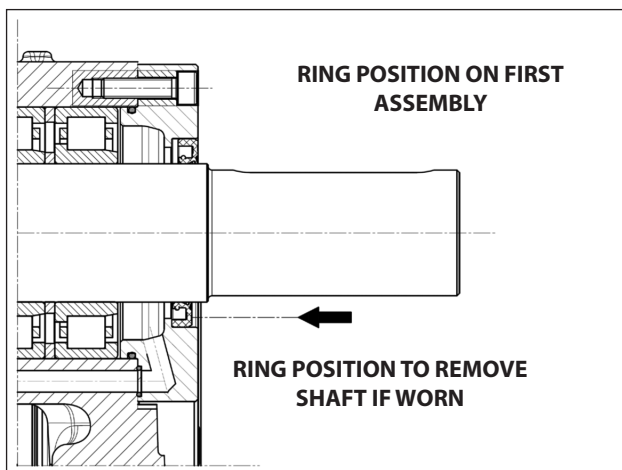

Fig. 64

Apply to the PTO bearing covers: the external O-ring (pos. ①, Fig. 65) and the lubrication hole O-ring (pos. ①, Fig. 66).

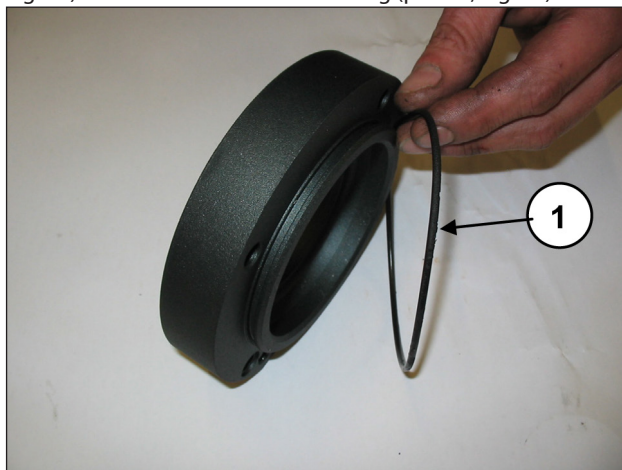

Fig. 65

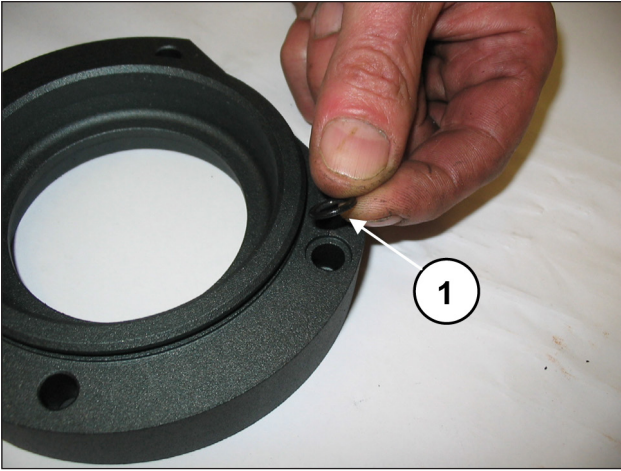

Fig. 66

Mount one of the PTO bearing covers (left or right) on the pump casing (pos. ①, Fig. 67) and fasten it with 4 M8x30 screws (pos. ①, Fig. 68).



Pay attention to the direction of assembly of the cover. The lubrication hole in the cover must correspond to the hole in the casing.

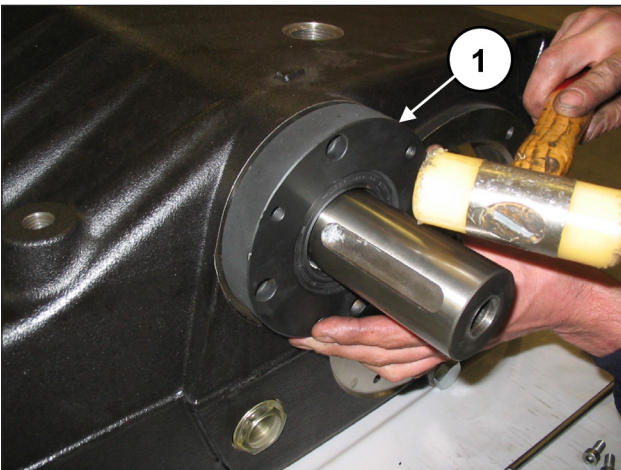

Fig. 67

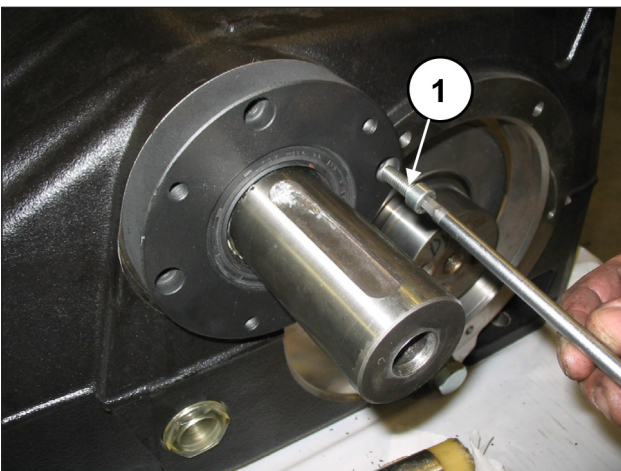

Fig. 68

Repeat the operation on the other side:
 Insert the internal ring (pos. ①, Fig. 61) and external ring (pos. ①, Fig. 62) of the last bearing.
 Mount the missing PTO bearing cover on the pump casing (pos. ①, Fig. 67) and fasten it with 4 M8x30 screws (pos. ①, Fig. 68).
 Calibrate the 4+4 screws with a torque wrench, as shown in chapter 3.

Pre-assemble the two bearing support covers:
 Insert the bearing using an extractor hammer (pos. ①, Fig. 69) until 4 to 4.5 mm of the bearing is still protruding, as shown in Fig. 70.



Fig. 69

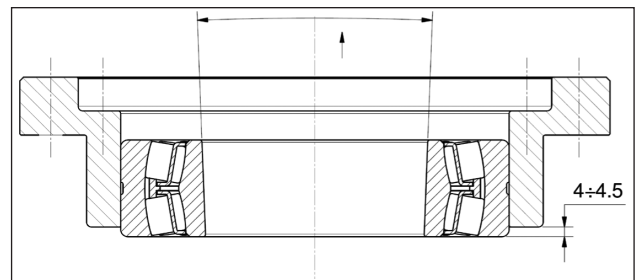

Fig. 70



The bearing in Fig. 70 has a tapered internal ring. Check that the taper goes from the outside inwards to allow inserting the bush.

Apply the O-ring to the outside of the bearing support cover (pos. ①, Fig. 71).

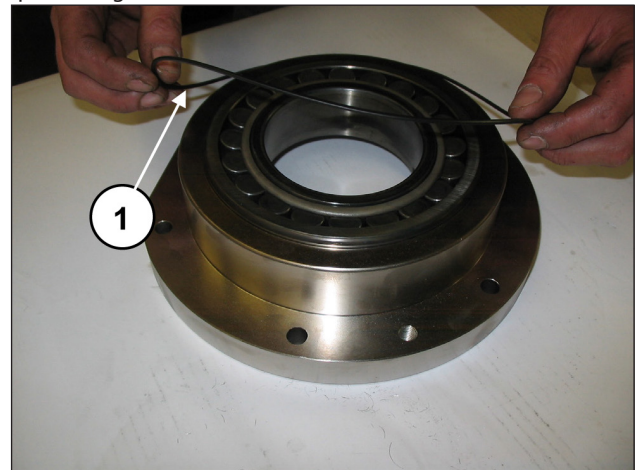

Fig. 71

Repeat the operation with the other cover.
 Lock the three connecting rod assemblies, using the special tool code 27566200 (pos. ①, Fig. 40).

Apply two M16 threaded pins to the end of the crankshaft and, while keeping it raised (pos. ①, Fig. 72), insert the bearing support cover complete with bearing and O-ring (pos. ①, Fig. 73) using an extractor hammer. Repeat the operation on the other side

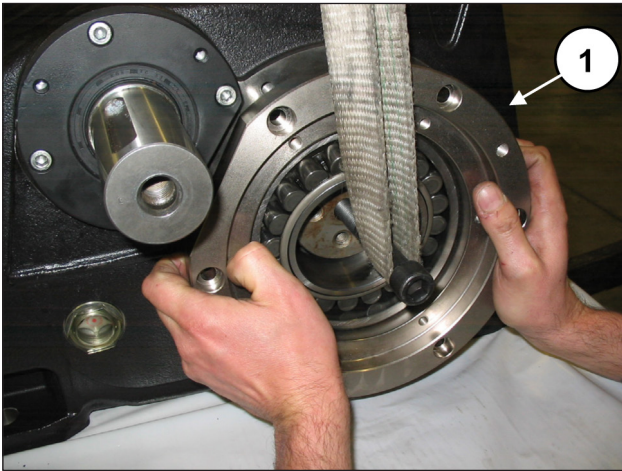

Fig. 72

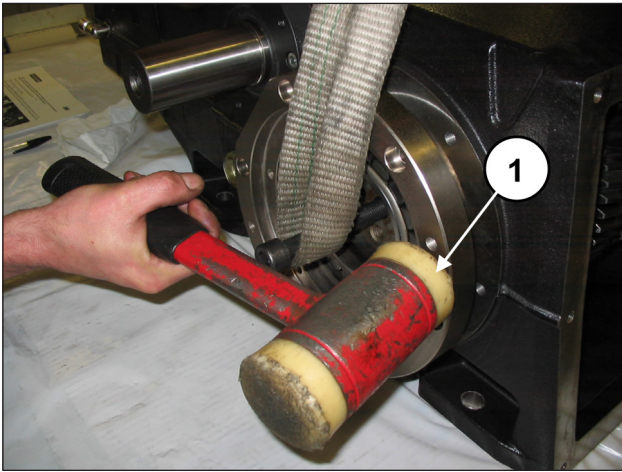

Fig. 73

Fasten the bearing support covers with 6+6 x M10x30 screws (pos. ①, Fig. 74).

Calibrate the screws with a torque wrench as indicated in chapter 3.

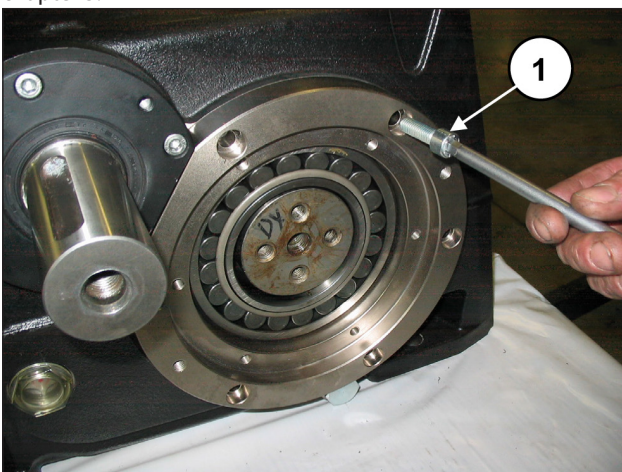

Fig. 74

Partly insert the two pressure bushes, keeping the bend shaft lifted up by means of the previously-mounted M16 pin (pos. ①, Fig. 75).

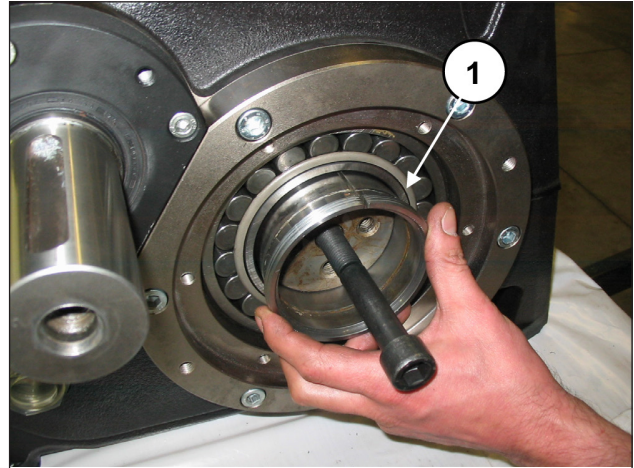

Fig. 75

Insert the pressure bush completely onto the bend shaft (pos. ①, Fig. 76 and Fig. 77) using an extractor hammer and a buffer.

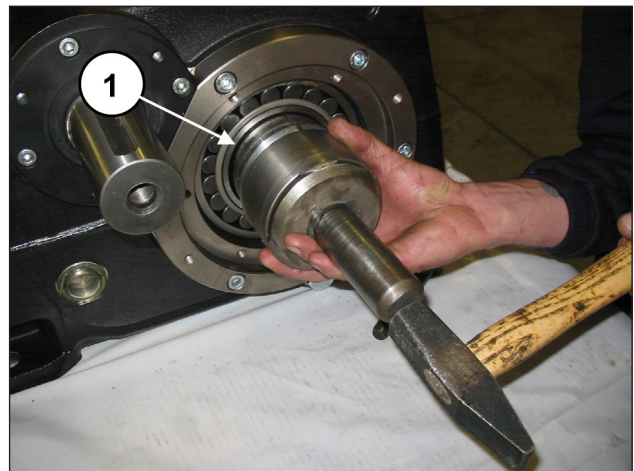

Fig. 76

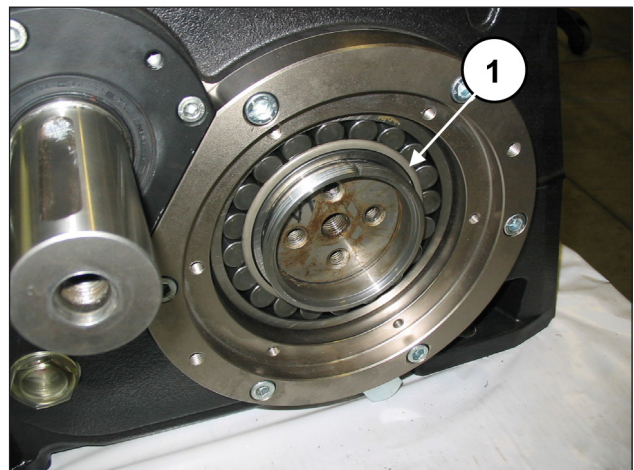

Fig. 77



The pressure bush must be inserted dry (no lubricant oils).

Insert the bush until the outside (conical) surface perfectly couples with the inside of the bearing. During insertion, make sure that the bearing stays in contact with the bend shaft shoulder.

Repeat the operation on the other side.

Insert the bush locking flanges into the conical bushes (pos. ①, Fig. 78).
 Apply a sufficiently long (35-40 mm) M16 screw to the M16 hole on the bend shaft and screw it in, until the flange is touching the bush (pos. ①, Fig. 79). Do not tighten the screw.

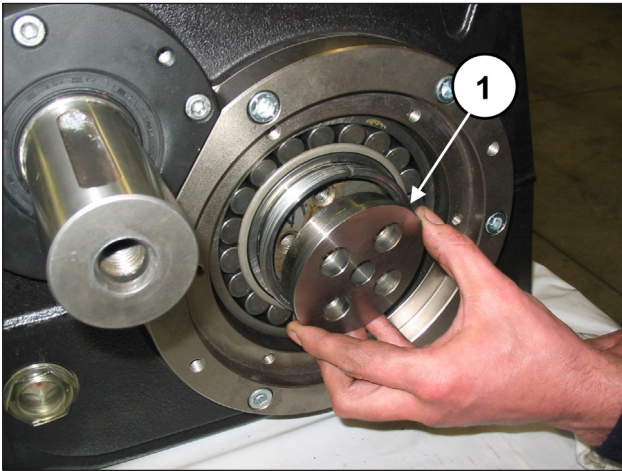

Fig. 78

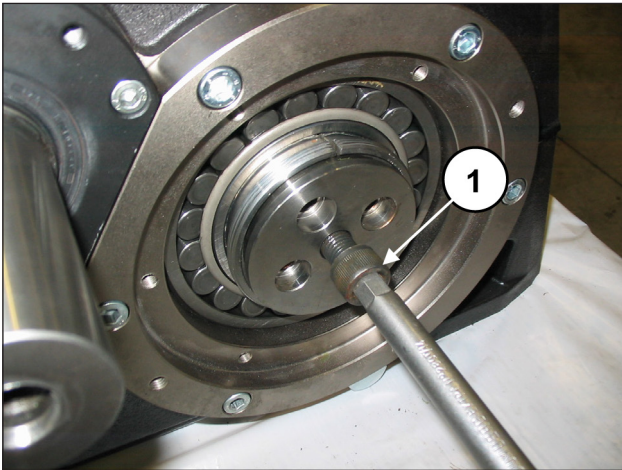

Fig. 79

Repeat the operation on the other side.
 Remove the tool for blocking the con-rods code 27566200 (pos. ①, Fig. 40).
 Insert the upper half-bearings between the con-rods and the bend shaft (pos. ①, Fig. 80).

⚠ For proper assembly of the half-bearings, ensure that the reference tab on the half-bearings are positioned in their housing on the half support (pos. ①, Fig. 81).

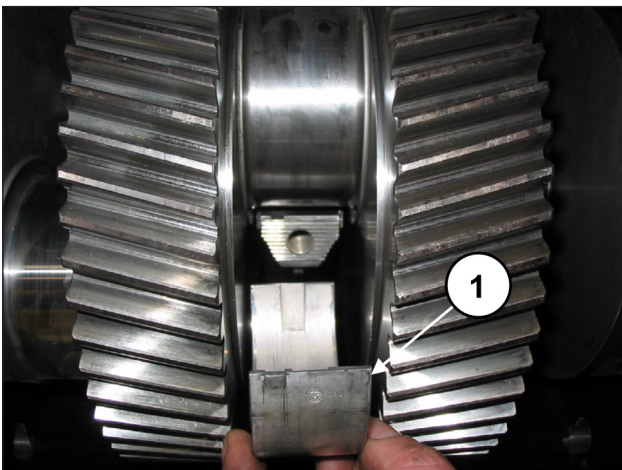

Fig. 80

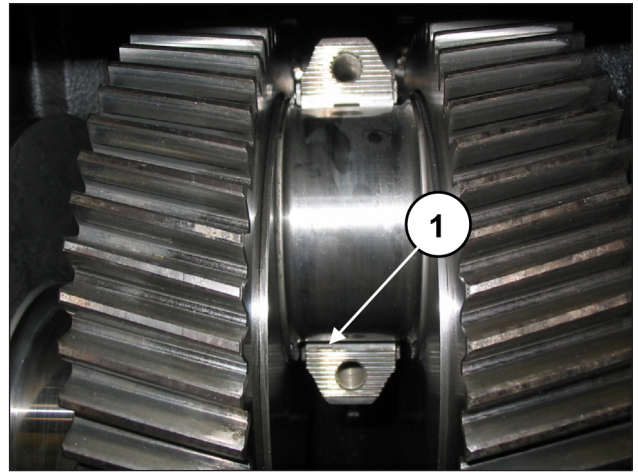

Fig. 81

Apply the lower half-bearings to the caps (pos. ①, Fig. 82) ensuring that the half-bearing reference notches are positioned in their housing on the cap (pos. ②, Fig. 82).
 Fasten the caps to the half supports by means of M12x1.25x87 screws (pos. ①, Fig. 83).
 Calibrate the screws with a torque wrench as indicated in chapter 3 bringing the screws to tightening torque at the same time.

⚠ Note the correct assembly direction of the caps. Numbering must be turned upward.

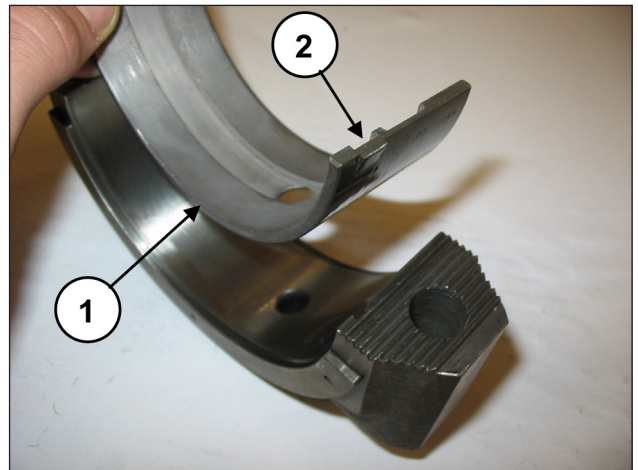

Fig. 82

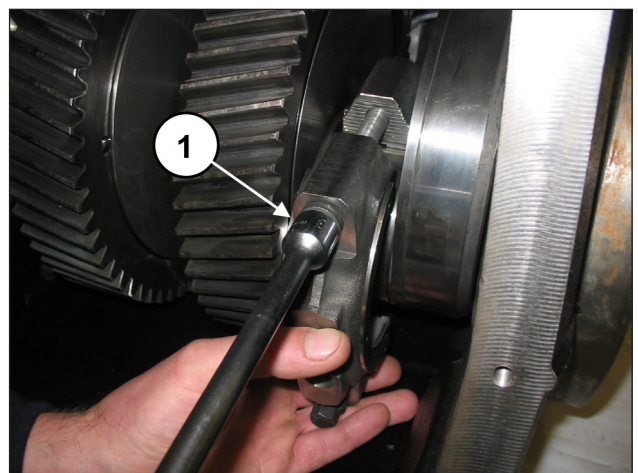

Fig. 83

⚠ After finishing this operation, verify that the con-rods have axial clearance in both directions.

Insert a shim under the shank of the central connecting rod, to stop the rotation of the bend shaft (pos. ①, Fig. 84).

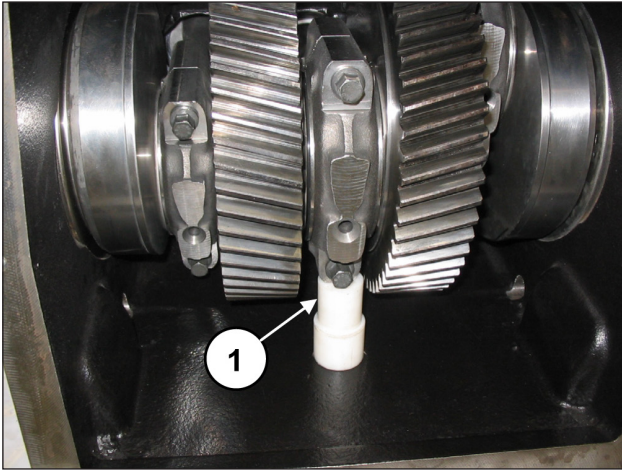

Fig. 84

Measure the distance X indicated in Fig. 85 between the conical bush and the bend shaft bearing.

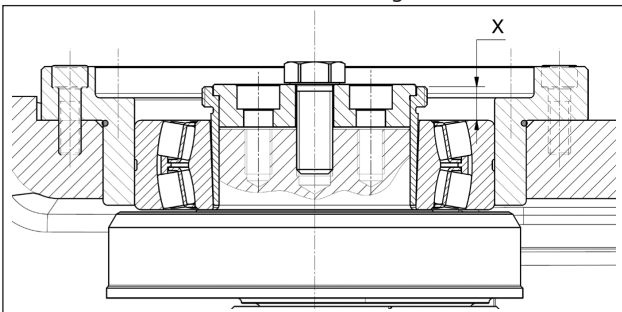

Fig. 85

Screw in the M16 screw until there is a reduction in the distance X of between 0.7 mm and 0.8 mm (Fig. 86).

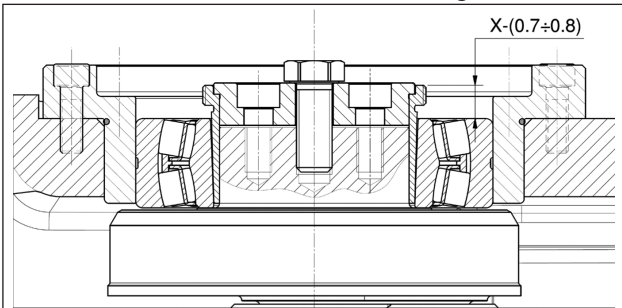

Fig. 86

Repeat the operation on the other side.
Remove the M16 screw from the bend shaft.
Screw the two bush locking flanges onto the crankshaft using 4+4 x M12x25 screws (pos. ①, Fig. 88).



Apply LOCTITE 243 to the threads of the M12x25 screws (pos. ①, Fig. 87).

Calibrate the screws with a torque wrench as indicated in chapter 3.

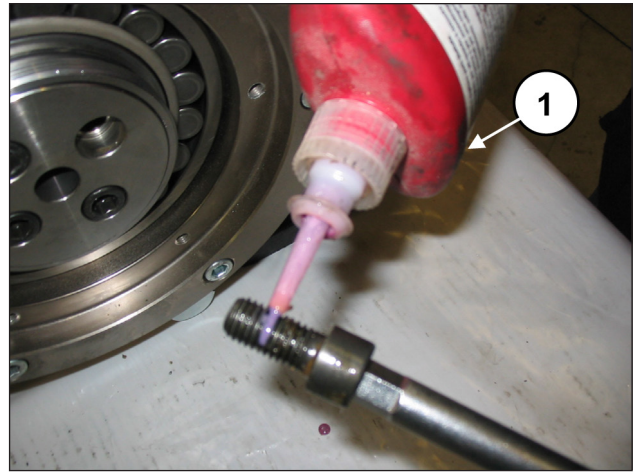

Fig. 87

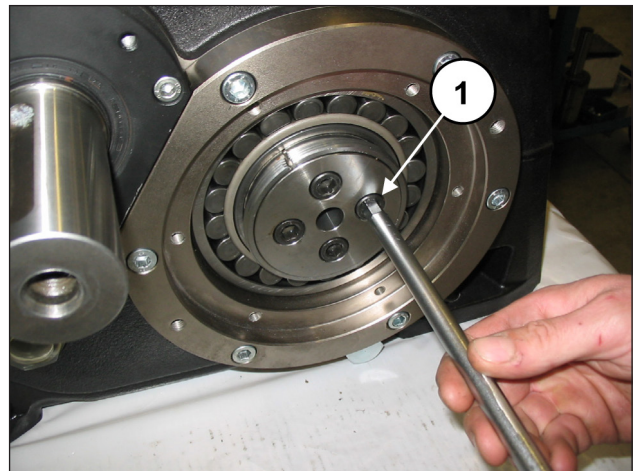

Fig. 88

Remove the anti-rotation shim from under the shank of the central connecting rod.

Mount the two bearing covers (with their O-rings) (pos. ①, Fig. 89) using 6+6 x M8x20 screws (pos. ①, Fig. 90).
Calibrate the screws with a torque wrench as indicated in chapter 3.

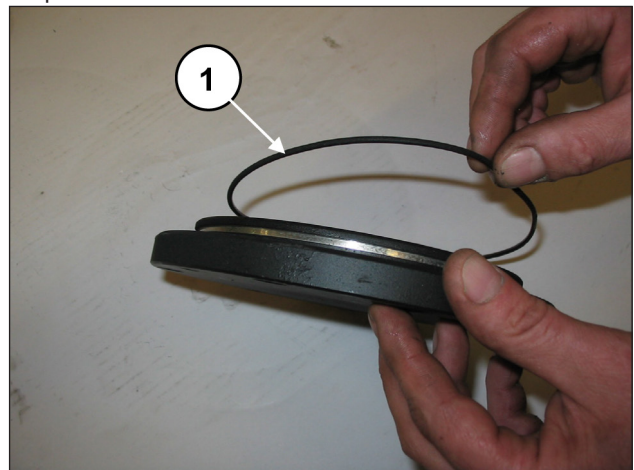

Fig. 89

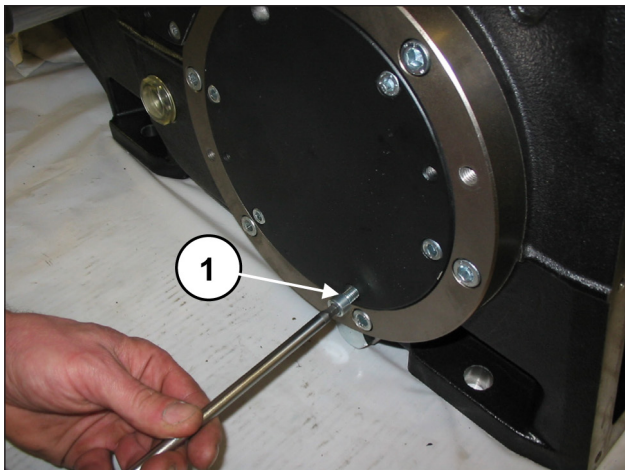

Fig. 90

Insert the O-ring on the rear cover (pos. ①, Fig. 91) and fasten it to the casing with 10 x M8x20 screws (pos. ①, Fig. 92). Calibrate the screws with a torque wrench as indicated in chapter 3.

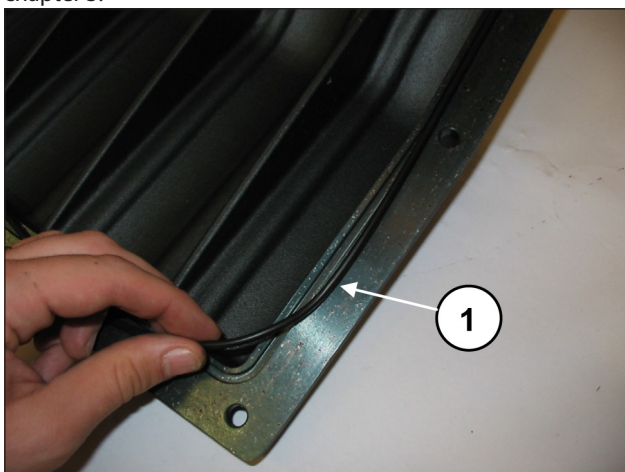

Fig. 91

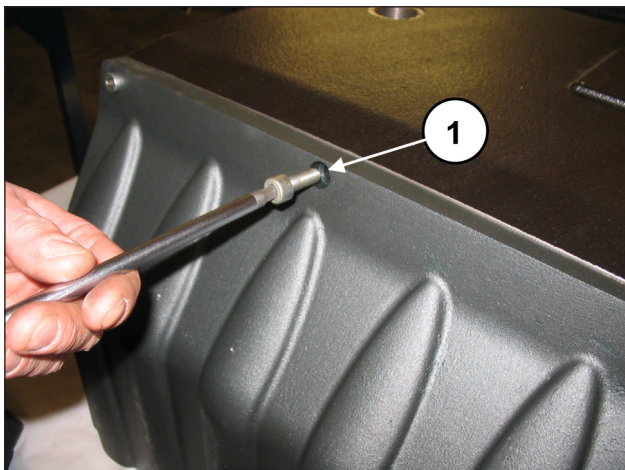

Fig. 92

Mount the radial seal ring onto the oil seal cover (pos. ①, Fig. 93) using a buffer code 27910900.

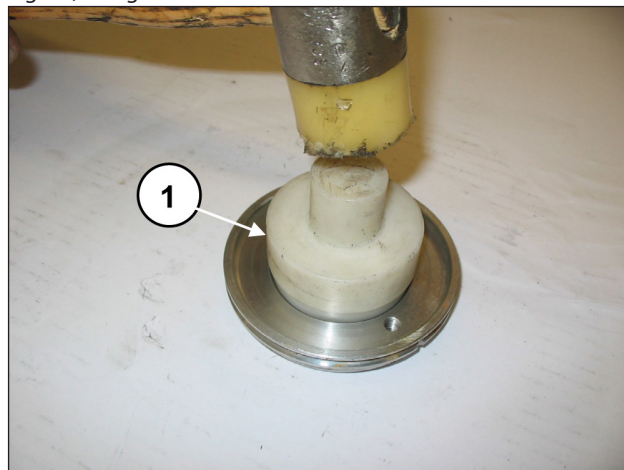

Fig. 93

Position the O-ring (pos. ①, Fig. 94) in the seat of the oil seal cover.

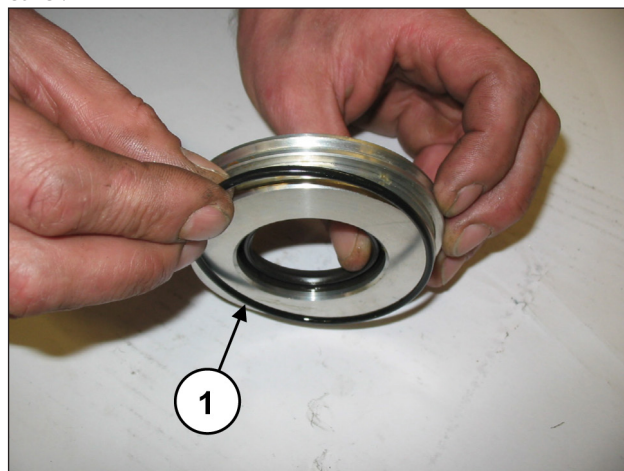

Fig. 94

Insert the assembly into the casing and into the seat provided, making sure that the cover completely enters its seat (pos. ①, Fig. 95) being careful not to damage the lip of the radial seal ring. Screw in the oil seal covers using 2 x M6x30 grub screws (pos. ①, Fig. 96).

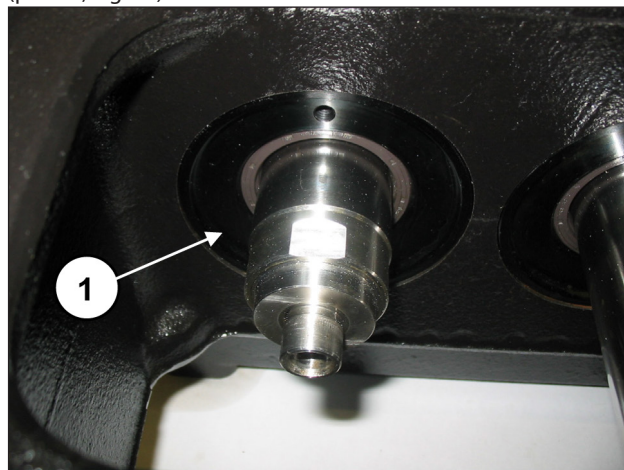

Fig. 95

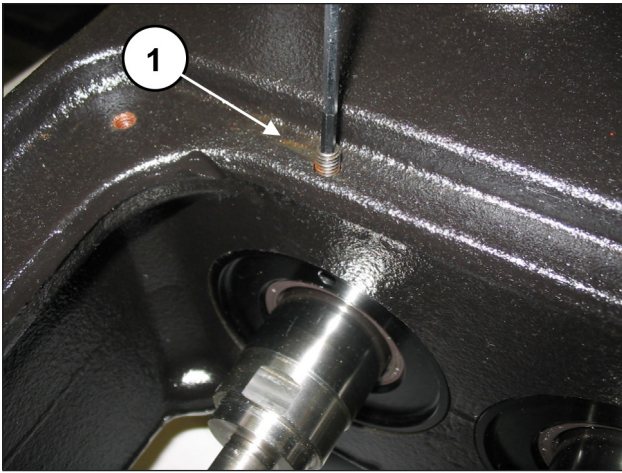

Fig. 96

Calibrate the screws with a torque wrench as indicated in chapter 3.

Position the spray-guard and the spray-guard spacer ring in the seat on the piston head stem (pos. ①, Fig. 97 and Fig. 98).

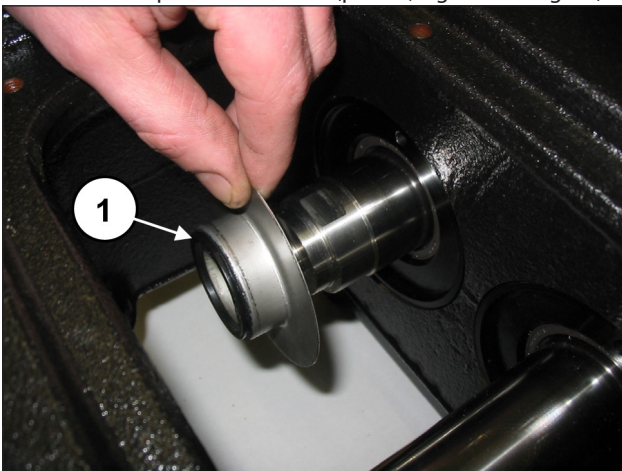

Fig. 97

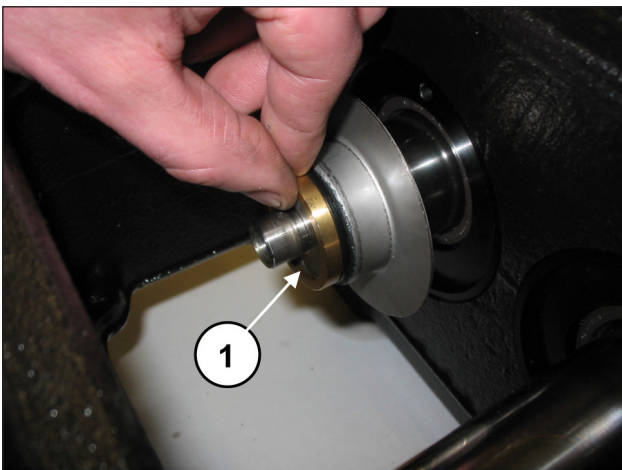

Fig. 98

Insert the O-ring on the two inspection covers (pos. ①, Fig. 99) and assemble the covers with the use of 4+4 M6x14 screws (pos. ①, Fig. 100).

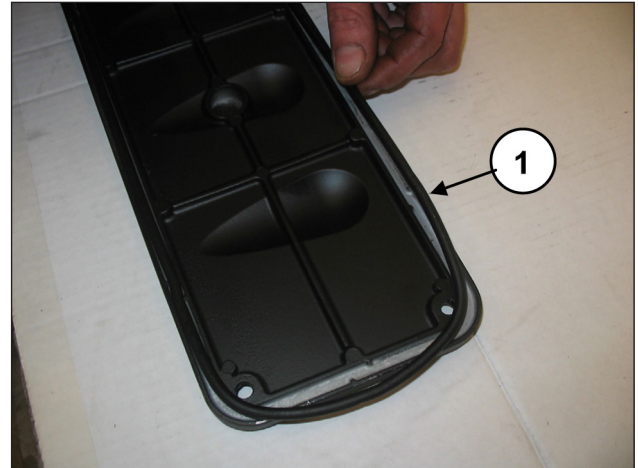

Fig. 99

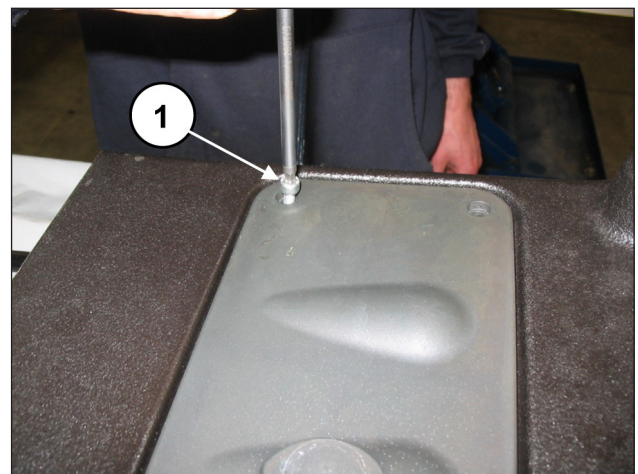

Fig. 100

Calibrate the screws with a torque wrench as indicated in chapter 3 "Screw Tightening Calibration".

Mount the shaft end cover and affix it to the casing using 3 x M8x20 screws (pos. ①, Fig. 101).

Calibrate the screws with a torque wrench as indicated in chapter 3 "Screw Tightening Calibration".



Fig. 101

Apply the tab to the PTO shaft (pos. ①, Fig. 102).

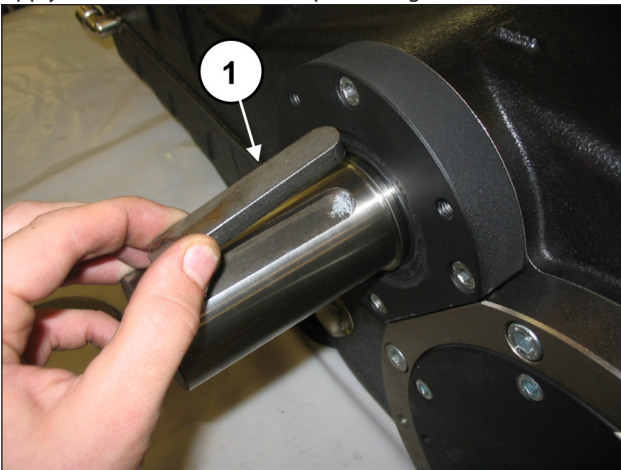

Fig. 102

2.1.3 Classes of increase

INCREASE TABLE FOR BEND SHAFTS AND CON-ROD HALF-BEARINGS			
Recovery classes (mm)	Upper Half-Bearing Code	Lower Half-Bearing Code	Correction on the shaft pin diameter (mm)
0.25	90931100	90930100	Ø92.75 0/-0.03 Ra 0.4 Rt 3.5
0.50	90931200	90930200	Ø92.50 0/-0.03 Ra 0.4 Rt 3.5

INCREASE TABLE FOR PUMP CASING AND PISTON GUIDE		
Recovery classes (mm)	Piston Guide Code	Adjustments on the Pump Casing housing (mm)
1.00	79050543	Ø81 H6 +0.022/0 Ra 0.8 Rt 6

2.2 REPAIRING HYDRAULIC PARTS

2.2.1 Dismantling the head – valve units

The head needs preventive maintenance as indicated in the **Use and maintenance manual**.

Operations are limited to inspection or replacement of valves, if necessary.

Proceed as follows to remove the valve units:

Unscrew the valve opening device by means of a 30 mm spanner (pos. ①, Fig. 103).

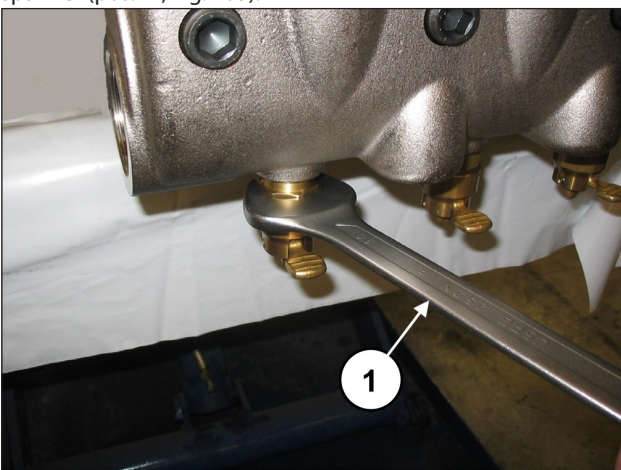

Fig. 103

Apply two supports with G2" threading to the outlet connections of the head (pos. ①, Fig. 104) and then unscrew the 8 M16x150 screws (pos. ①, Fig. 105).

Take care to not subject the pistons to knocks or bumps when taking them out of the head.

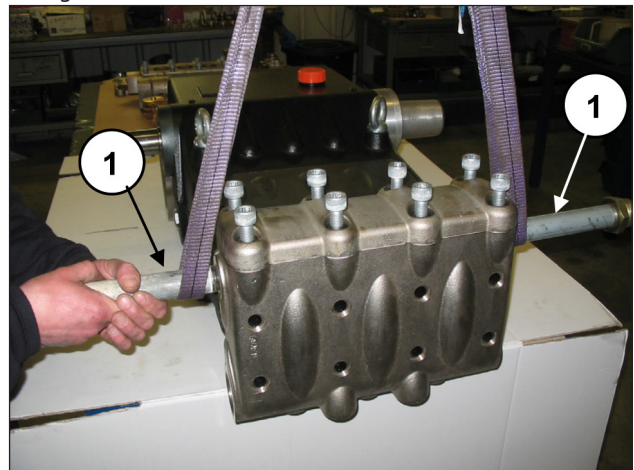

Fig. 104

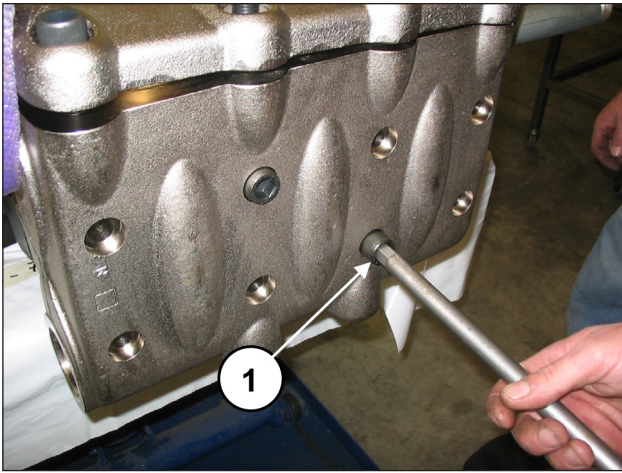

Fig. 105

Unscrew and remove the 8 M16x55 screws of the valve cover (pos. ①, Fig. 106) and remove the cover (pos. ①, Fig. 107).

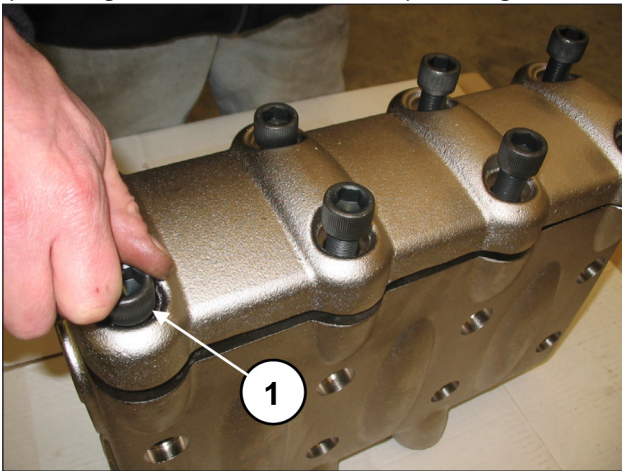

Fig. 106

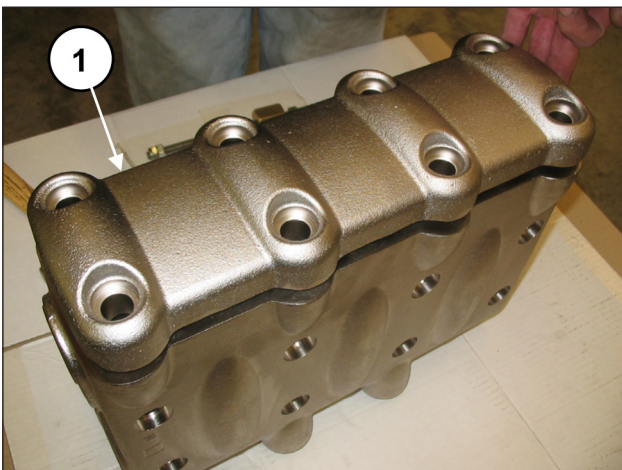

Fig. 107

Extract the valve plug with the use of an extractor hammer to be applied on the M10 hole of the valve plug (pos. ①, Fig. 108).

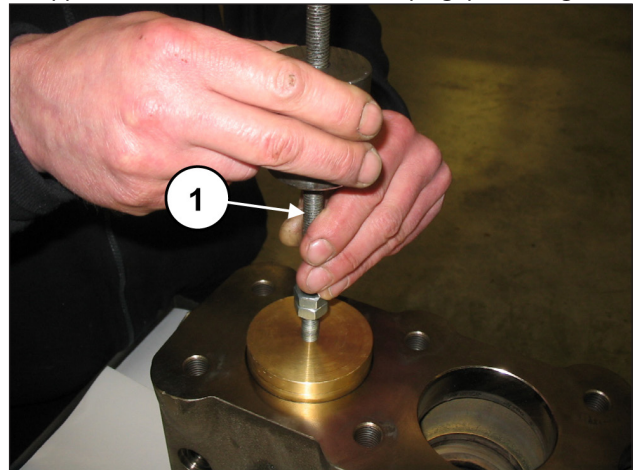

Fig. 108

Remove the spring (pos. ①, Fig. 109).

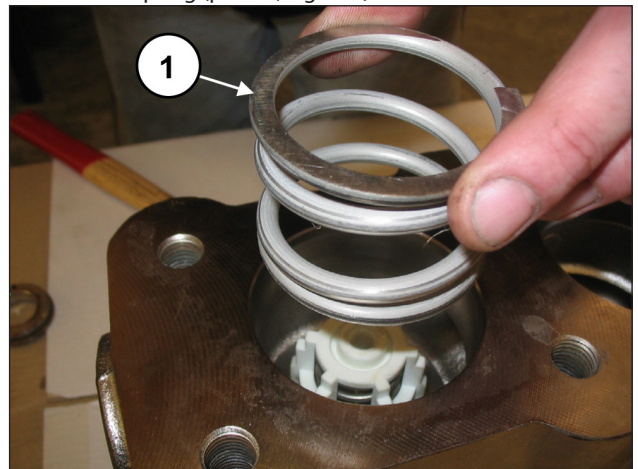

Fig. 109

Extract the outlet valve unit with an extractor hammer to be applied on the M10 hole of the valve guide (pos. ①, Fig. 110).

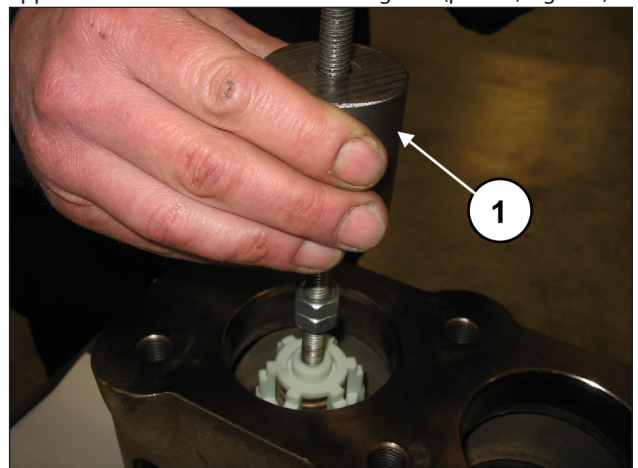

Fig. 110



If removing the outlet valve unit proves to be particularly difficult (for example because of incrustations due to prolonged inactivity of the pump), use the extractor tool (code 27516400).

Take out the valve guide spacer using an 8 mm hex wrench (pos. ①, Fig. 111).

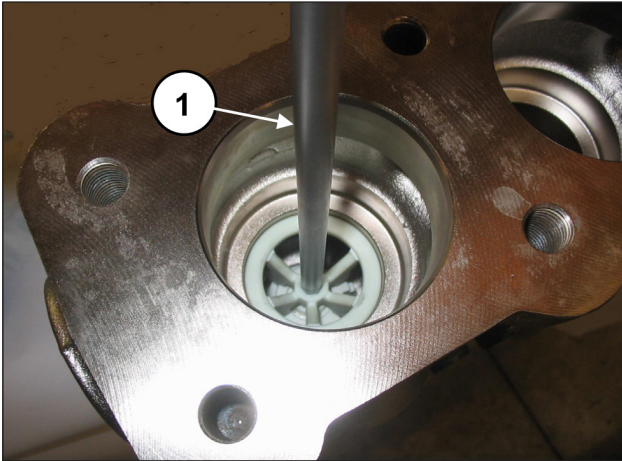

Fig. 111

Extract the suction valve unit with an extractor hammer to be applied on the M10 hole of the valve guide (pos. ①, Fig. 112).

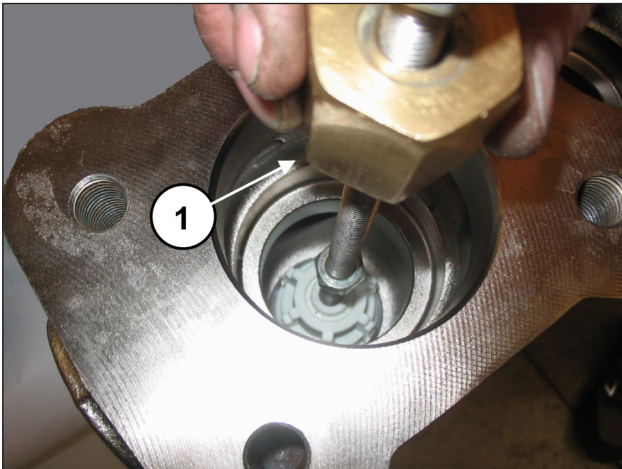

Fig. 112



If removing the suction valve unit proves to be particularly difficult (for example because of incrustations due to prolonged inactivity of the pump), use the extractor tool (code 27516200 (for LK36-LK40-LK45) or code 27516300 (for LK50-LK55-LK60)(pos. ①, Fig. 113) as indicated.

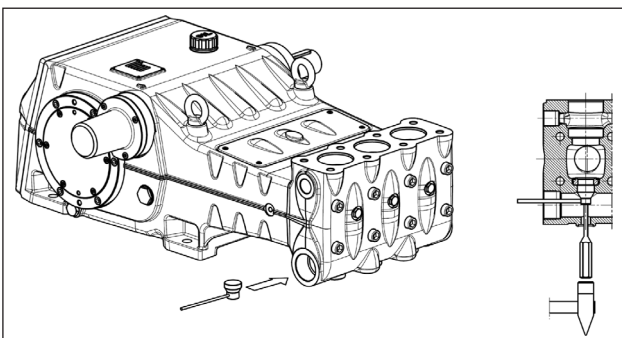

Fig. 113

Remove the suction and outlet valve units, unscrewing an M10 screw in such a way to press on the inner guide and remove the valve guide from the valve housing (pos. ①, Fig. 114).

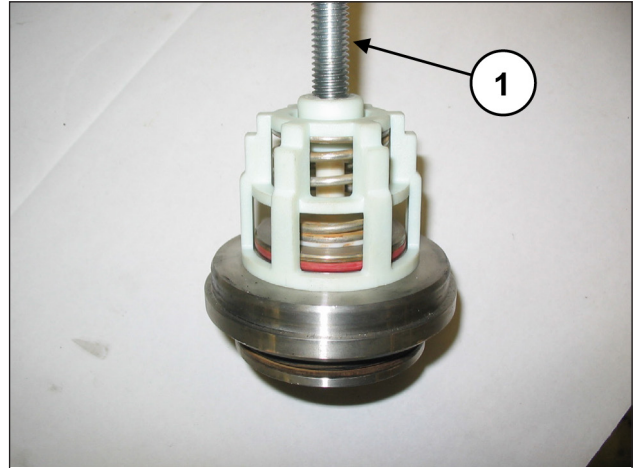

Fig. 114

2.2.2 Assembling the head – valve units



Pay particular attention to the conditions of the various components and replace if necessary. At every valve inspection, replace all O-rings both in the valve unit and in the valve plugs.



Before repositioning the valve units, thoroughly clean and dry the relative housings on the head indicated by the arrows (pos. ①, Fig. 115).

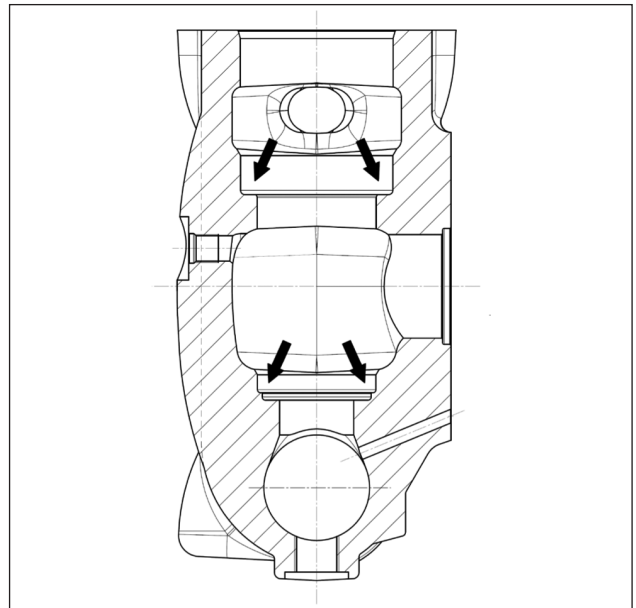

Fig. 115

Proceed with reassembly following the reverse order indicated in par. 2.2.1.

Assemble the suction and outlet valve units (Fig. 116 and Fig. 117) taking care not to invert the previously disassembled springs.

To facilitate insertion of the valve guide in its housing, you can use a pipe resting on the horizontal guide planes (Fig. 118) and use an extractor hammer acting on the whole circumference



Fig. 116

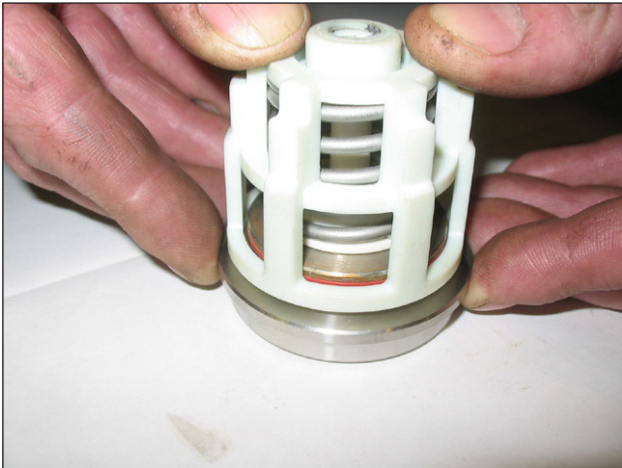

Fig. 117



Fig. 118



Proceed with insertion of the valve units (suction and outlet) in the head, taking care to follow the correct insertion sequence of O-rings and anti-extrusion rings.

The proper sequence of valve unit assembly on the head is as follows:

Insert the anti-extrusion ring, exploded view pos. 4 (pos. ①, Fig. 119).

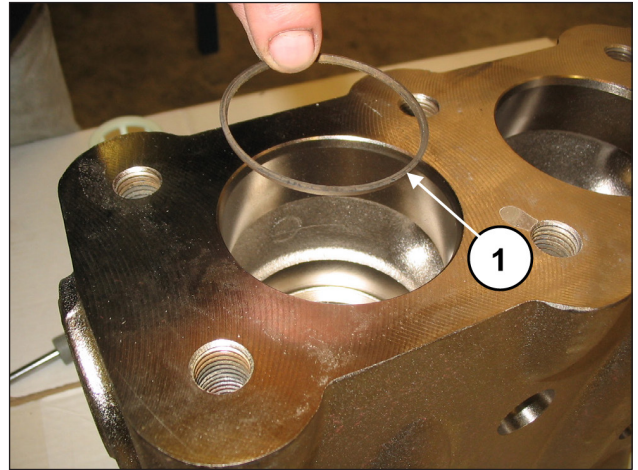

Fig. 119

Insert the O-ring, exploded view pos. 5 (pos. ①, Fig. 120).

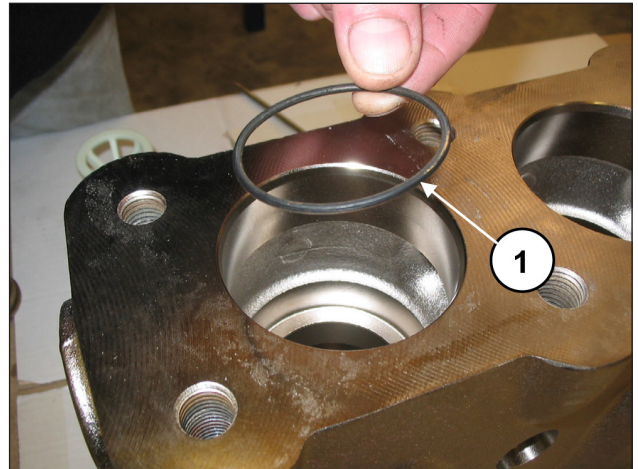

Fig. 120

Ensure that the O-ring and anti-extrusion ring are perfectly placed in their housings.

Insert the suction valve unit (pos. ①, Fig. 121) and then the spacer (pos. ①, Fig. 122).

The complete valve unit must be fully inserted into the bottom and should look like the image in pos. ①, Fig. 122.

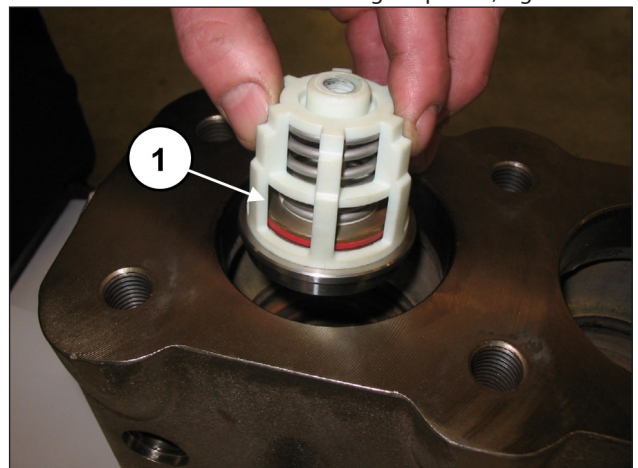

Fig. 121

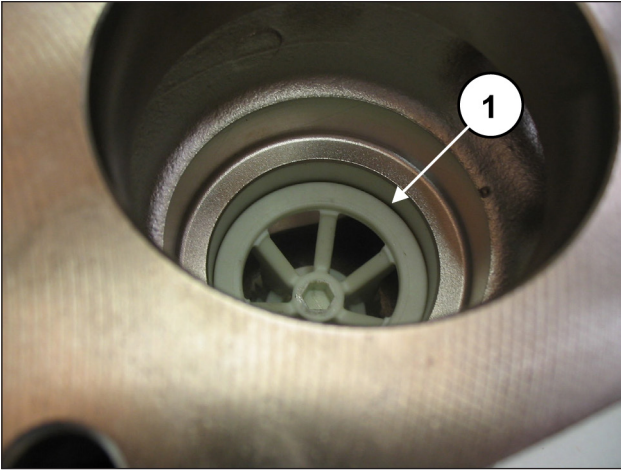

Fig. 122

Assemble the O-ring, exploded view pos. 5 (pos. ①, Fig. 123) and the anti-extrusion ring, exploded view pos. 15 (pos. ②, Fig. 123) on the outlet valve housing.

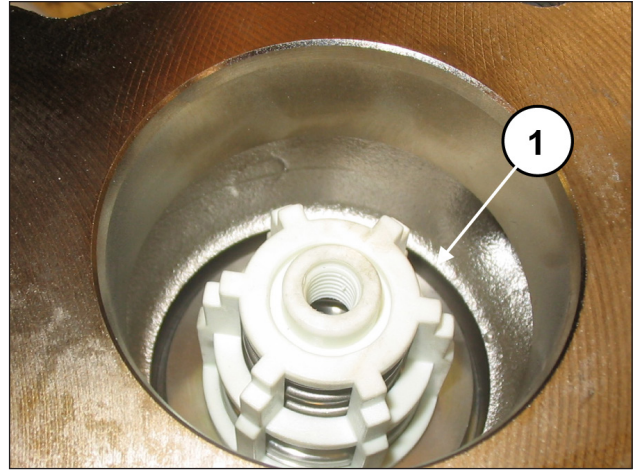

Fig. 125

Insert the anti-extrusion ring, exploded view pos. 16 (pos. ①, Fig. 126).

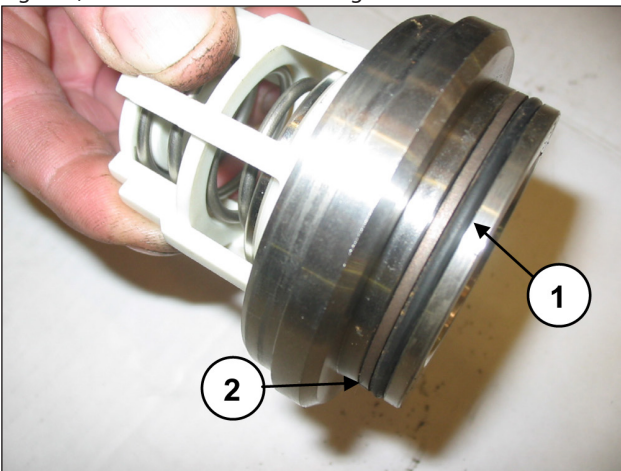

Fig. 123

Insert the outlet valve unit (pos. ①, Fig. 124). The valve unit must be fully inserted into the bottom and should look like the image in pos. ①, Fig. 125.

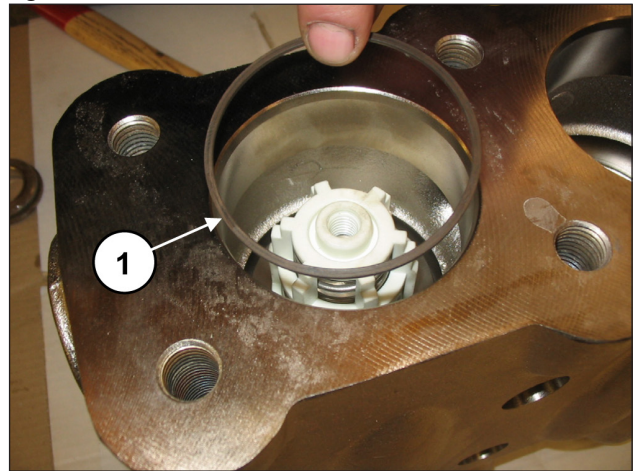

Fig. 126

Insert the O-ring, exploded view pos. 17 (pos. ①, Fig. 127).

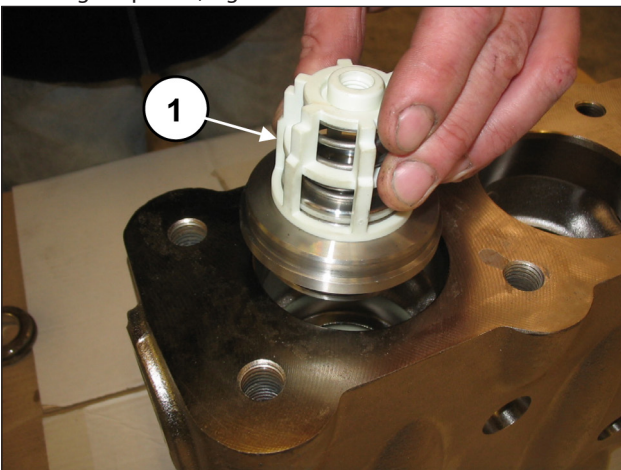

Fig. 124

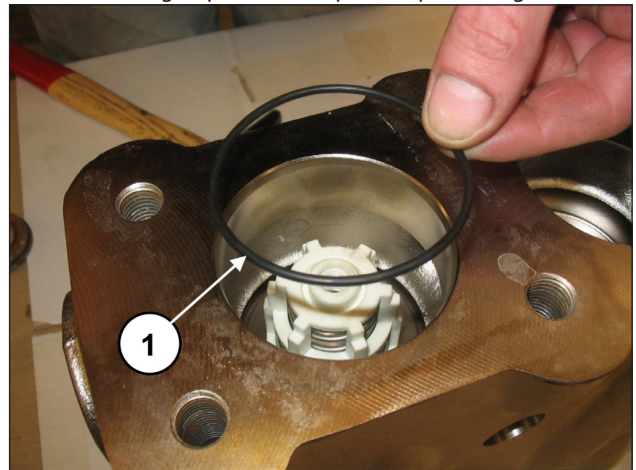

Fig. 127



Pay special attention to O-ring insertion indicated in pos. ①, Fig. 128. Use a special tool code 27516000 (for LK36-LK40-LK45) or code 27516100 (for LK50-LK55-LK60) to prevent the O-ring getting cut during insertion.

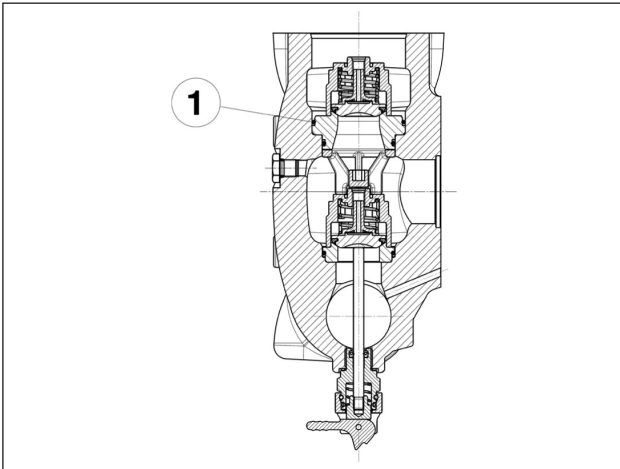

Fig. 128

Insert the valve housing ring (pos. ①, Fig. 129) and the spring (pos. ①, Fig. 130).

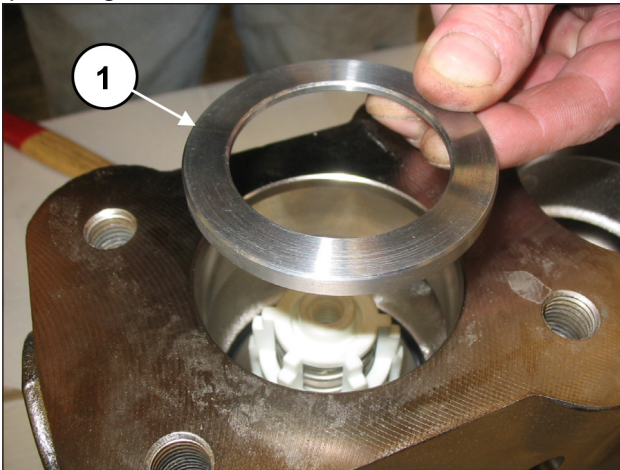

Fig. 129

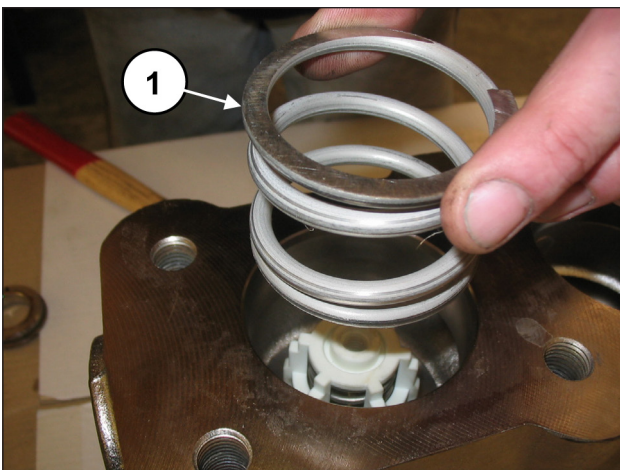

Fig. 130

Assemble the O-ring, exploded view pos. 17 (pos. ①, Fig. 131) and the anti-extrusion ring, exploded view pos. 21 (pos. ②, Fig. 131) on the outlet valve plug.

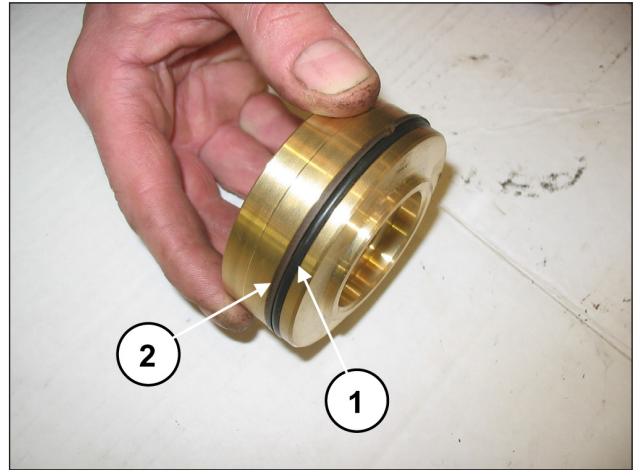

Fig. 131

Insert the valve plug housing complete with O-ring and anti-extrusion rings.

After having completed assembly of the valve units and the valve plug, apply the valve cover (pos. ①, Fig. 132) and screw in the 8 M16x55 screws (pos. ①, Fig. 133).

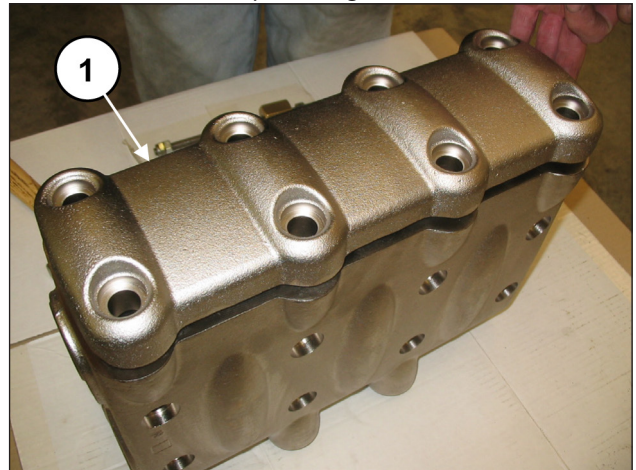

Fig. 132

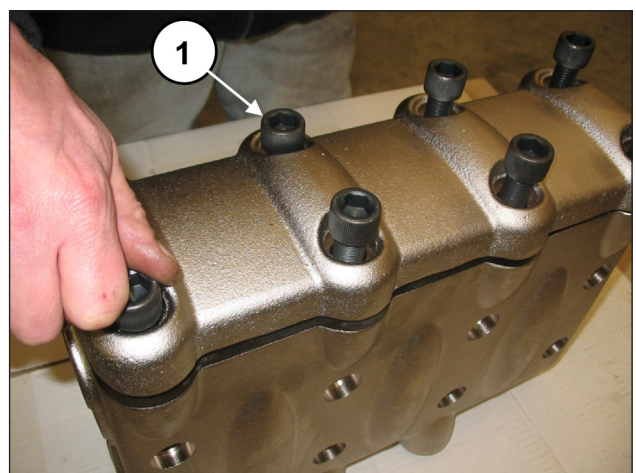

Fig. 133

Assemble the pump casing head (pos. ①, Fig. 134) taking care not to hit the pistons and screw in the 8 M16x150 screws (pos. ①, Fig. 135).

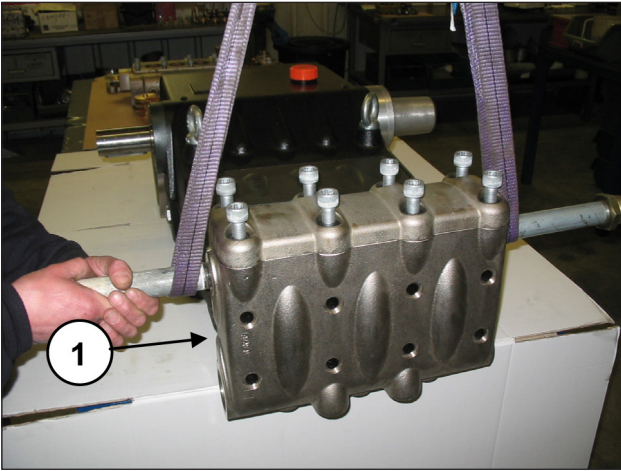

Fig. 134

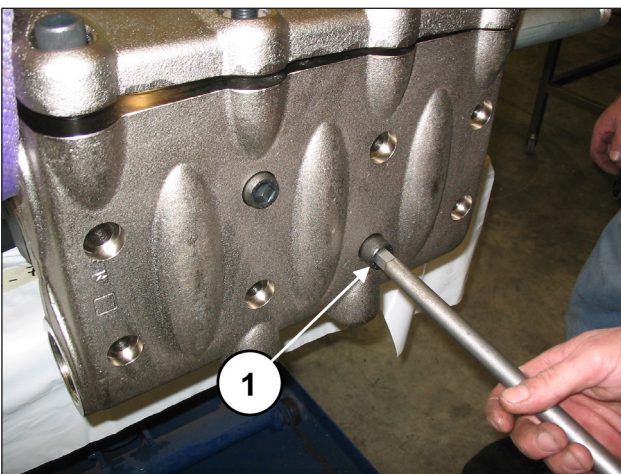

Fig. 135

Proceed with calibration of the M16x150 screws with a torque wrench as indicated in chapter 3 "Screw Tightening Calibration".



Tighten the 8 M16x150 screws starting crosswise from the 4 inner screws (see Fig. 135), to then continue with the 4 outer screws, always tightening crosswise.

Calibrate the M16x55 screws of the cover with a torque wrench as indicated in chapter 3 "Screw Tightening Calibration".

Apply the valve opening devices (pos. ①, Fig. 136) and screw them in with the use of a 30 mm spanner (pos. ①, Fig. 137).

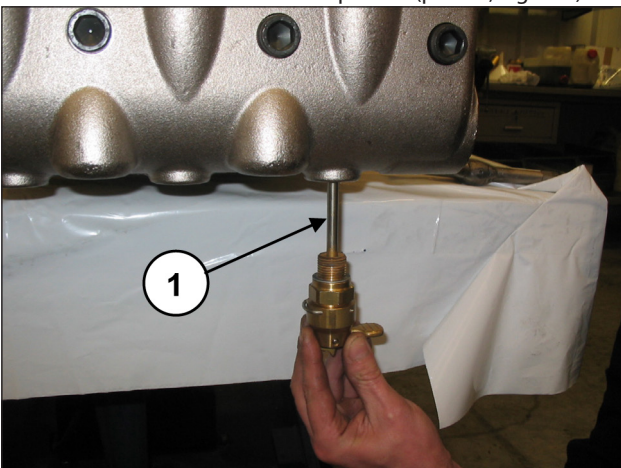

Fig. 136

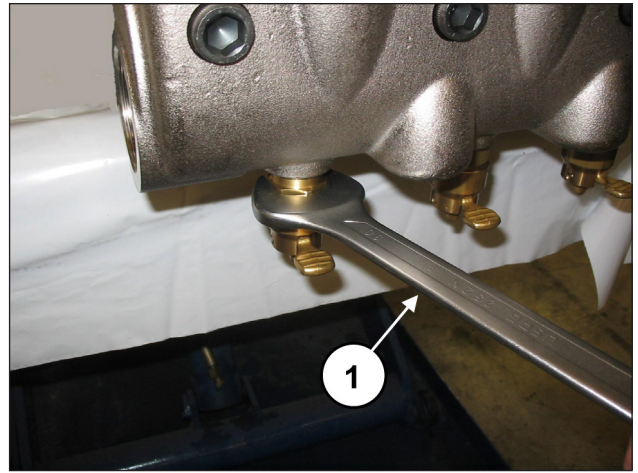

Fig. 137

2.2.3 Disassembly of the piston unit – supports – seals

The piston unit requires preventive checks as indicated in the preventive maintenance table in the *Use and maintenance manual*.

Maintenance is limited to visual inspection of any drainage from the hole present on the lower cover. If abnormalities / variations on the outlet pressure gauge or dripping from the drainage hole circuit are detected, the seal pack will have to be checked and replaced.

Proceed as follows to remove the piston units:

To access the piston unit, unscrew the M16x150 screws and remove the head.



Remove the head taking care to avoid hitting the pistons.

Disassemble pistons unscrewing the fixing screws (pos. ①, Fig. 138).

Remove the piston from the seal support and check that its surfaces do not present any scratches, signs of wear or cavitation

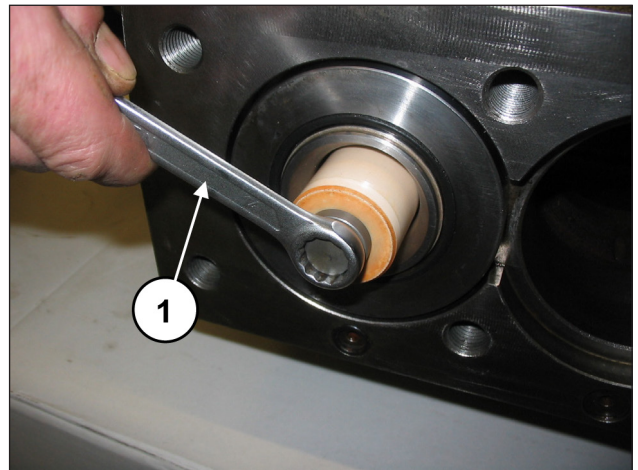

Fig. 138

Remove the upper inspection cover (pos. ①, Fig. 139) and the lower inspection cover (pos. ①, Fig. 140) by unscrewing the 4+4 attachment screws.

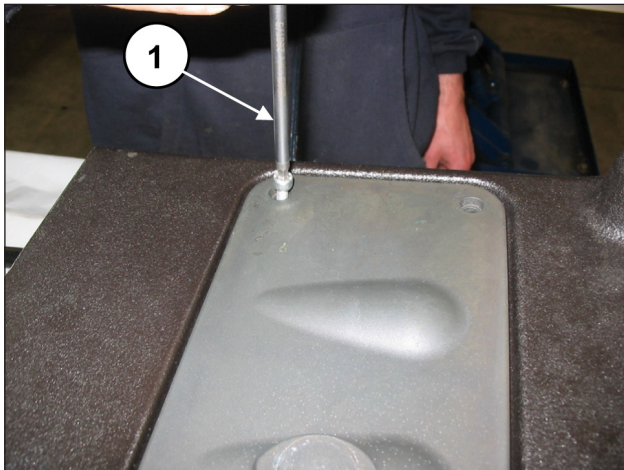

Fig. 139

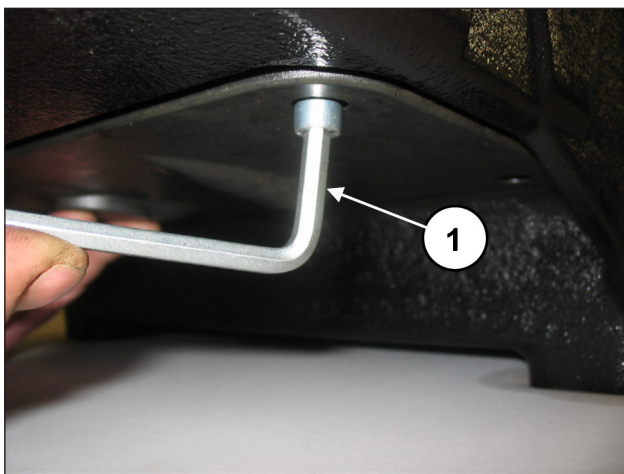

Fig. 140

Manually turn the shaft in such a way to bring the 3 pistons to the top dead centre position. Insert the buffering tool code 27516600 between the piston guide and the piston (pos. ①, Fig. 141).

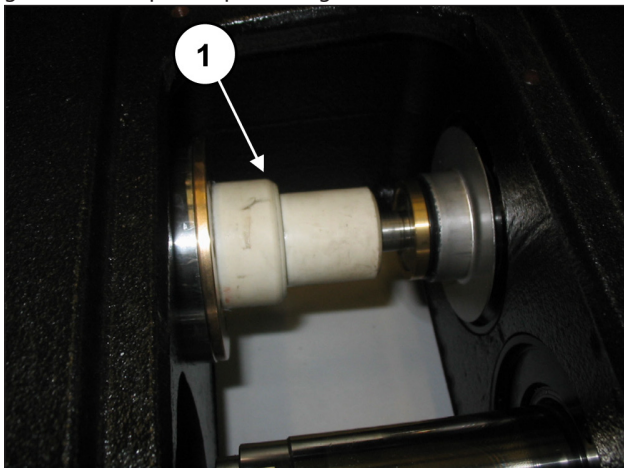

Fig. 141

Turning the shaft, have the piston guide move forward so that the buffer, moving ahead, can expel the seal support and the entire piston unit (pos. ①, Fig. 142).

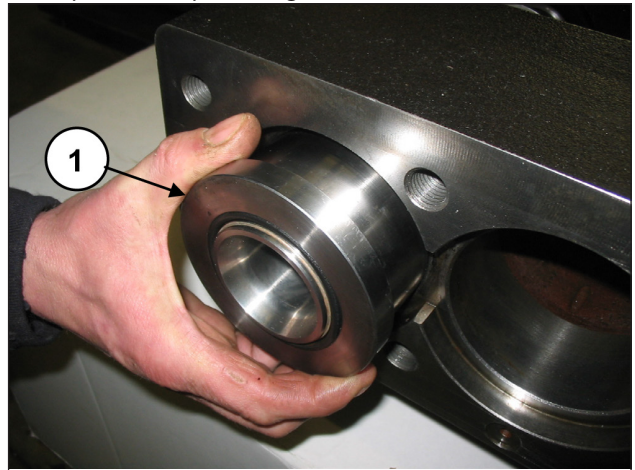

Fig. 142

Extract the seal support unit and the buffering tool. Slip the spray-guard spacer rings off the piston heads (pos. ①, Fig. 143) and also the spray-guards (pos. ①, Fig. 144).

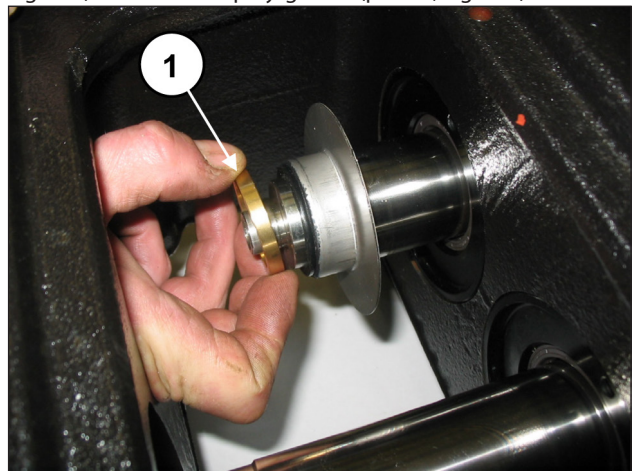

Fig. 143



Fig. 144

Separate the gasket support from the liner by using a compass spanner with $\varnothing 5$ round ends, available on the market (pos. ①, Fig. 145) and unscrew the support until it is completely removed (pos. ①, Fig. 146).

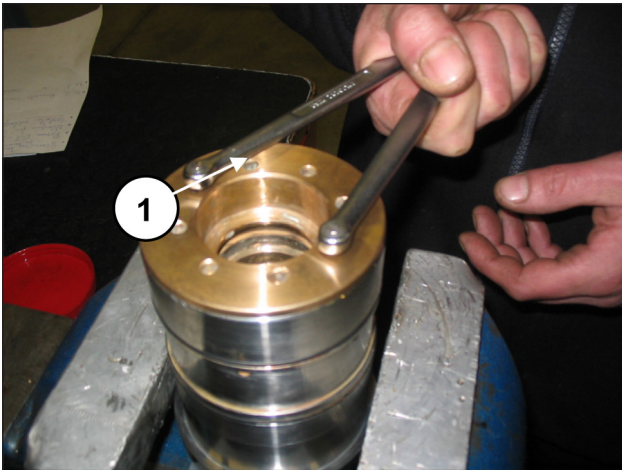

Fig. 145

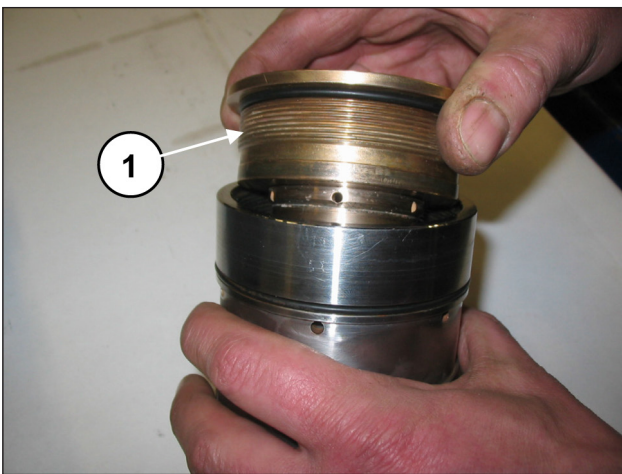

Fig. 146

Manually remove the head rings, the pressure gaskets and the restop rings (pos. ①, Fig. 147).



Fig. 147

To remove the low pressure seal, use a thickness gauge or another tool which will not damage the seal support housing (pos. ①, Fig. 148).

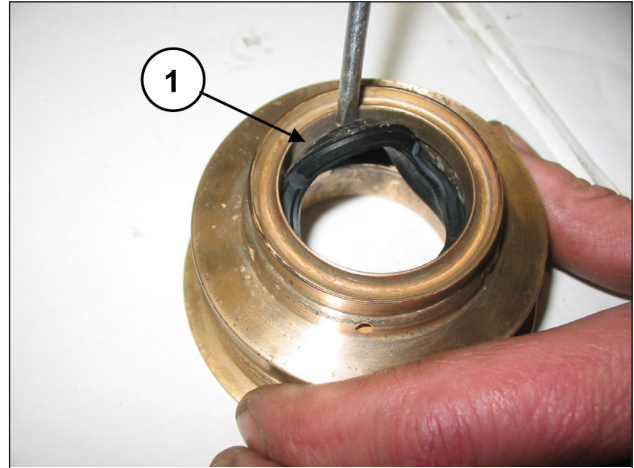

Fig. 148

2.2.4 Assembling the piston unit – supports – seals

Proceed with reassembly following the reverse order indicated in par. 2.2.3.



Replace the pressure seals moistening the lips with silicone grease (without spreading it), taking extra care not to damage them during liner insertion.



The O-rings and the pressure seals must be replaced at each disassembly.

Insert the low pressure seal in the seal support (pos. ①, Fig. 149) paying attention to the mounting direction which requires that the sealing lip be set forward (towards the head).

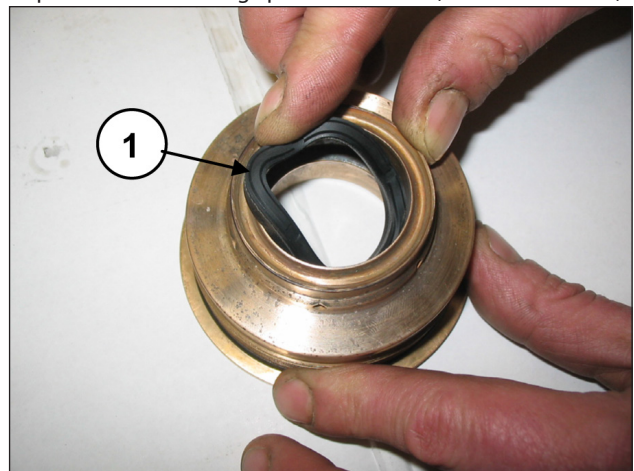

Fig. 149

Install the head ring (pos. ①, Fig. 150), the high pressure seal (pos. ①, Fig. 151) and the restop ring (pos. ①, Fig. 152).

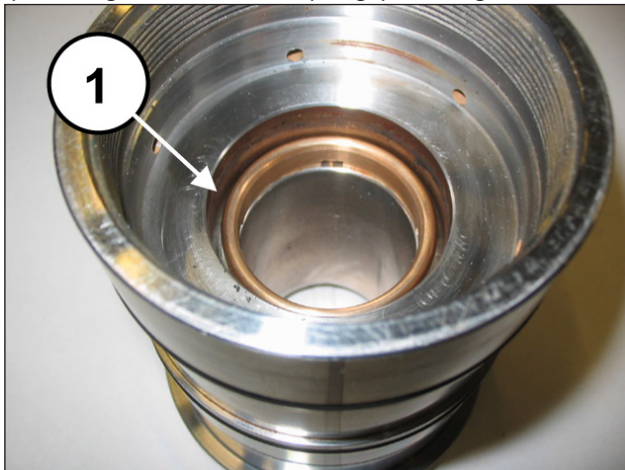

Fig. 150

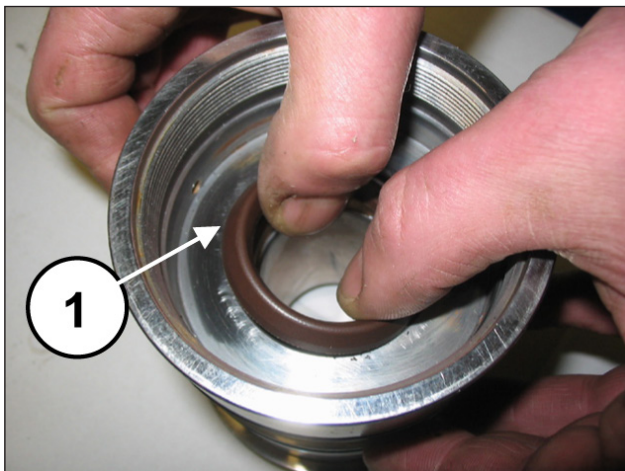

Fig. 151



Fig. 152

Place the O-ring for the gasket support in its seat (pos. ①, Fig. 153).

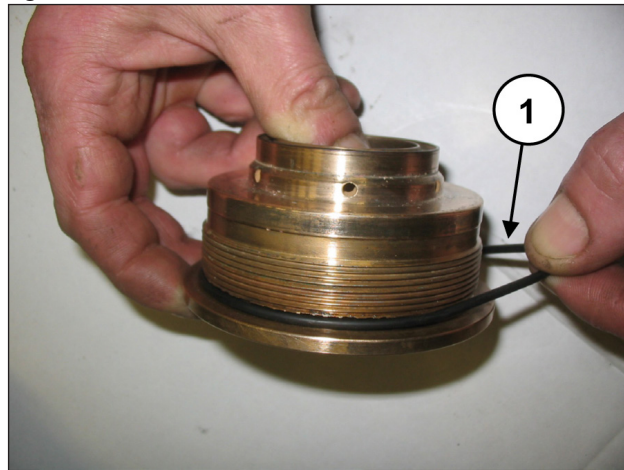

Fig. 153

Screw the gasket support to the liner (pos. ①, Fig. 154) and tighten using a compass spanner with Ø5 round ends, available on the market (pos. ①, Fig. 155) until the support abuts the liner.



Fig. 154

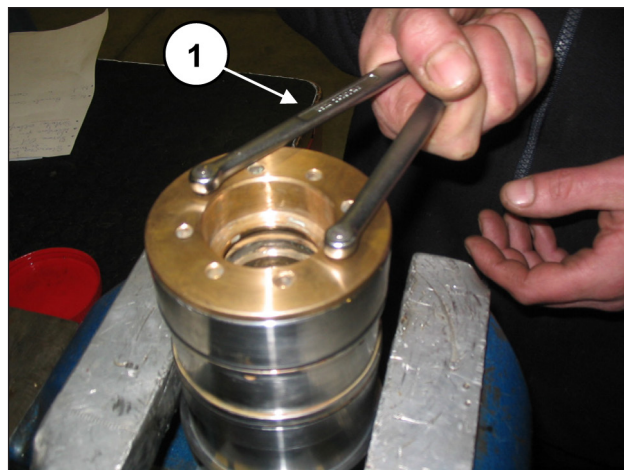

Fig. 155

Insert the $\text{\O}10 \times 18 \times 0.9$ washer in the piston fixing screw (pos. ①, Fig. 156).

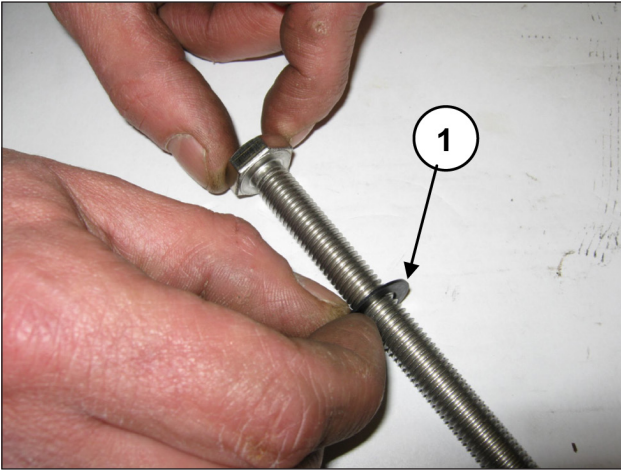

Fig. 156

Install the pistons on their respective guides (pos. ①, Fig. 157) and fasten them as per pos. ①, Fig. 158.

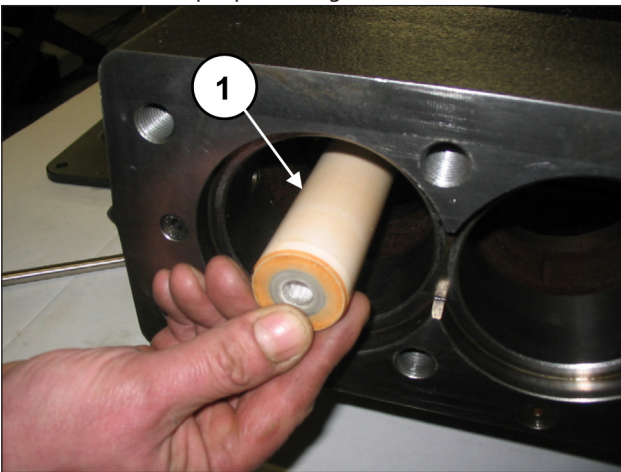

Fig. 157

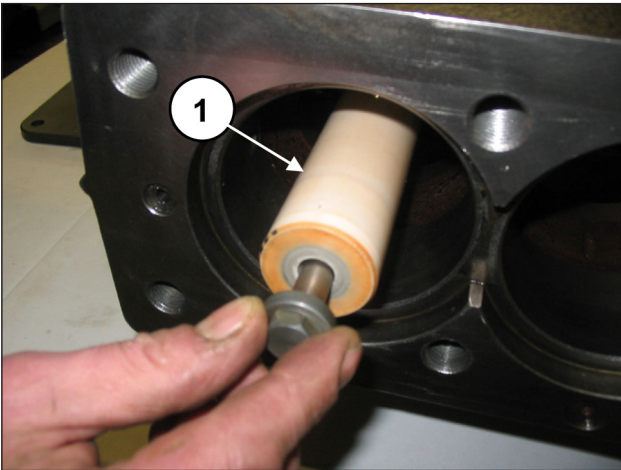

Fig. 158

Calibrate the screws with a torque wrench as indicated in chapter 3.

Insert the previously-assembled liner/gasket support block (complete with its two O-rings), until it is snugly in place (pos. ①, Fig. 159).

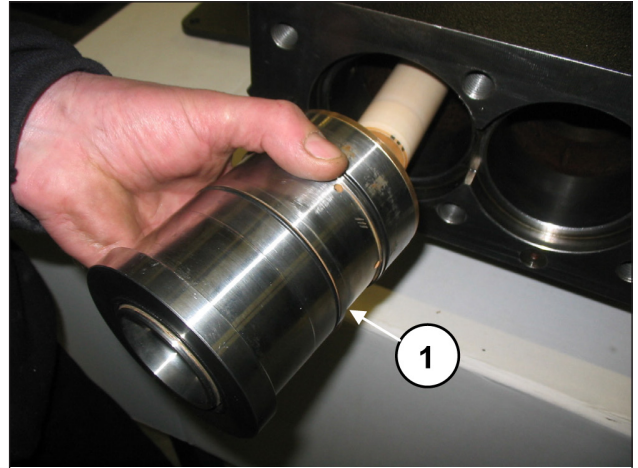

Fig. 159

Ensure that the liner-support block is positioned correctly down to the bottom of the housing (pos. ①, Fig. 160).

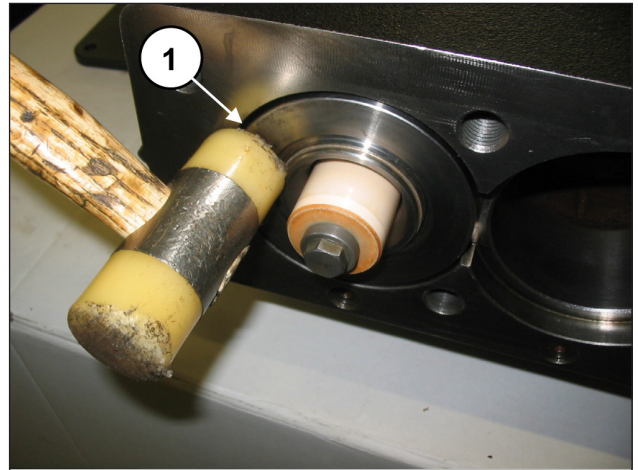

Fig. 160

Install the front O-ring in the liner (pos. ①, Fig. 161) and the recirculation hole O-ring (pos. ①, Fig. 162).

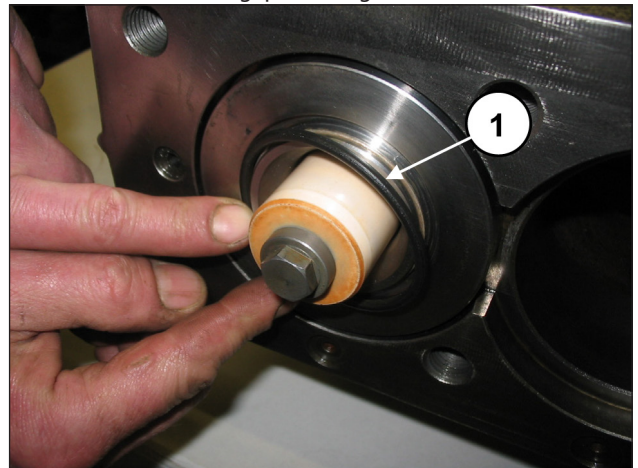

Fig. 161

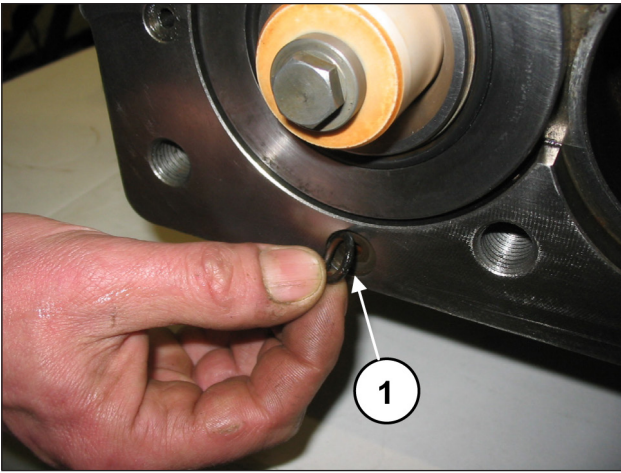

Fig. 162

Insert the O-ring on the inspection covers (pos. ①, Fig. 163) and assemble the covers with the use of 4+4 M6x14 screws (pos. ①, Fig. 164).

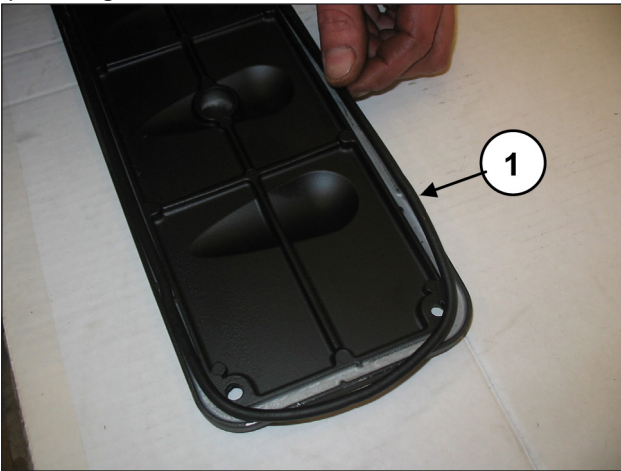

Fig. 163

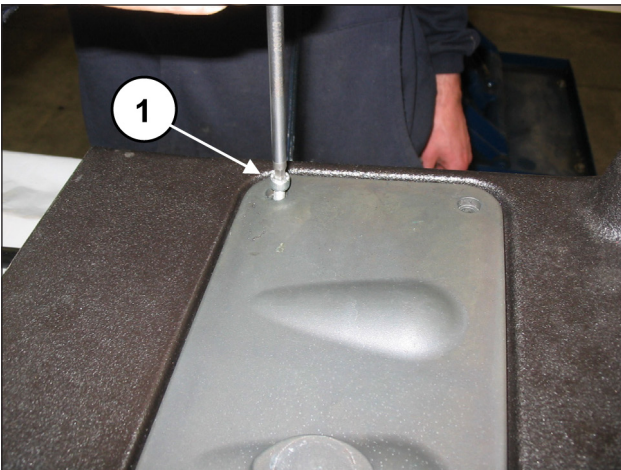

Fig. 164

Calibrate the screws with a torque wrench as indicated in chapter 3.

2.2.5 Recovering the heads

If the insides of the piston chambers on the head show clear signs of cavitation, due to incorrect pump feeding, it is possible to recover the damaged head and avoid the need to replace it.

In order to recover the head, perform the operations indicated in Fig. 165 for LK36-40-45 and in Fig. 166 for LK50-55-60:

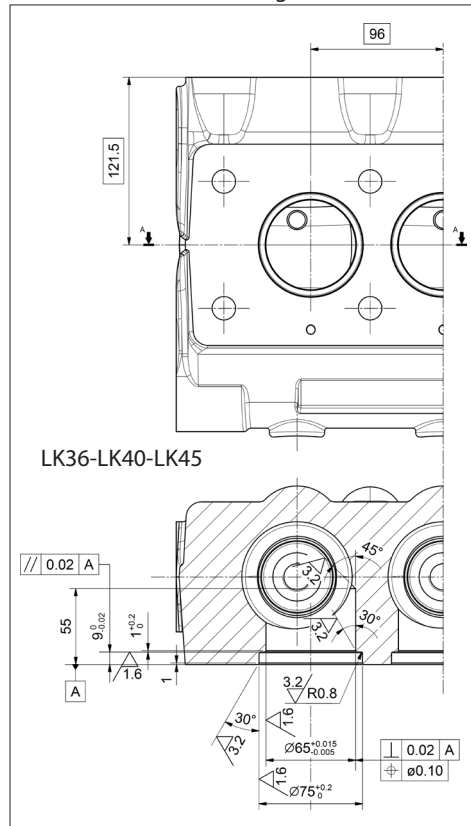

Fig. 165

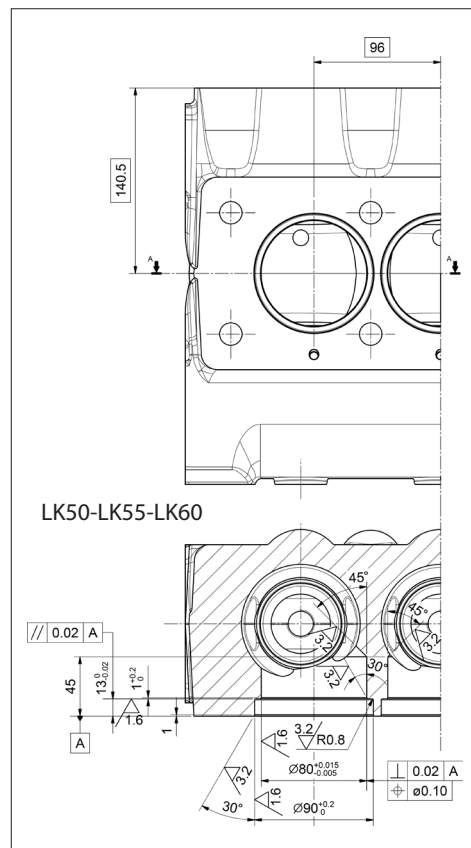

Fig. 166

The machined head must be assembled by driving in the bushes (pos. ①) together with the anti-extrusion rings (pos. ②) and O-rings (pos. ③) as shown in Fig. 167 for LK36-40-45 and in Fig. 168 for LK50-55-60:

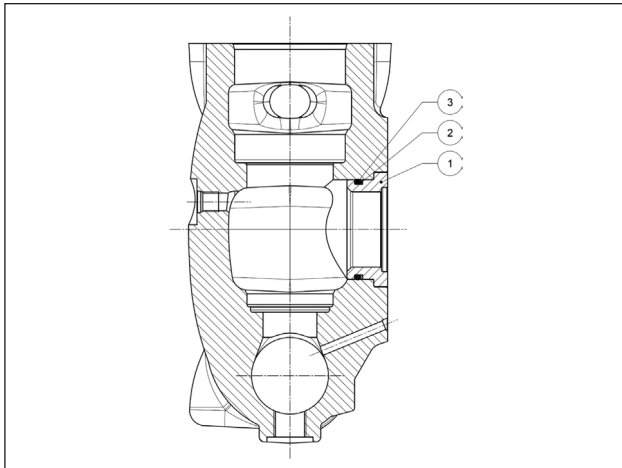

Fig. 167

no. 1 - Bush LK36-40-45 - code 78216756 - qty 3

no. 2 - Anti-extruder ring - code 90526880 - qty 6
no. 3 - O-ring - code 90410200 - qty 6

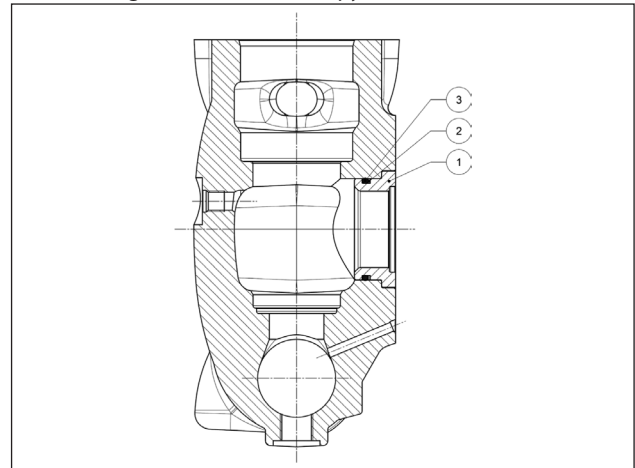

Fig. 168

no. 1 - Bush LK50-55-60 - code 78216656 - qty 3
no. 2 - Anti-extruder ring - code 90528500 - qty 6
no. 3 - O-ring - code 90412900 - qty 6

3 SCREW TIGHTENING CALIBRATION

Screw tightening must only be performed with a torque wrench.

Description	Exploded Drawing Position	Tightening Torque Nm
Casing cover M8x20 screw	54	25
G1/2x13 casing plug	78	40
M8x30 screw, PTO bearing cover	95	25
M8x20 screw, shaft end cover	54	25
M10x30 screw, bearing support cover	69	45
Upper and lower cover M6x14 screw	82	10
M8x20 screw, bearing cover	54	25
M12x1.25x87 screw, connecting rod tightening	52	75*
Piston guide M6x20 screw	49	10
M12x25 screw, bush locking flange	63	68.5
M10x160 screw, piston attachment	27	40
M16x55 screw, valve cover	26	333
G1/4"x13 head plug	13	40
M16x150 screw, head	25	333**
Valve opening device	2	40

* Achieve coupling torque tightening screws at the same time.

** Tighten the screws starting crosswise from the 4 inner screws (see Fig. 135), to then continue with the 4 outer screws, always tightening crosswise.

4 REPAIR TOOLS

Pump maintenance can be carried out with simple component disassembly and reassembly tools. The following tools are available:

For assembly:

Piston head radial seal ring	code 27910900
PTO shaft radial seal ring	code 27539500
	code 27548200
O-ring, outlet valve seat LK36-LK40-LK45	code 27516000
O-ring, outlet valve seat LK50-LK55-LK60	code 27516100

For disassembly:

Inlet valve seat LK36-LK40-LK45	code 27516200
Inlet valve seat LK50-LK55-LK60	code 27516300
Outlet valve seat	code 27516400
Liner block + seals support	code 27516600
Shaft (con-rod interlocking)	code 27566200

5 SPECIAL VERSIONS

The instructions for repairing special versions are given below. Unless specified otherwise, refer to the information above for the standard LK pump.

- LKN pumps: for repair, follow the instructions for the standard LK pump.

6 REPLACING THE CON-ROD FOOT BUSH

Perform cold-driving of the bush and the subsequent work bearing in mind the dimensions and tolerances shown in Fig. 169 below.

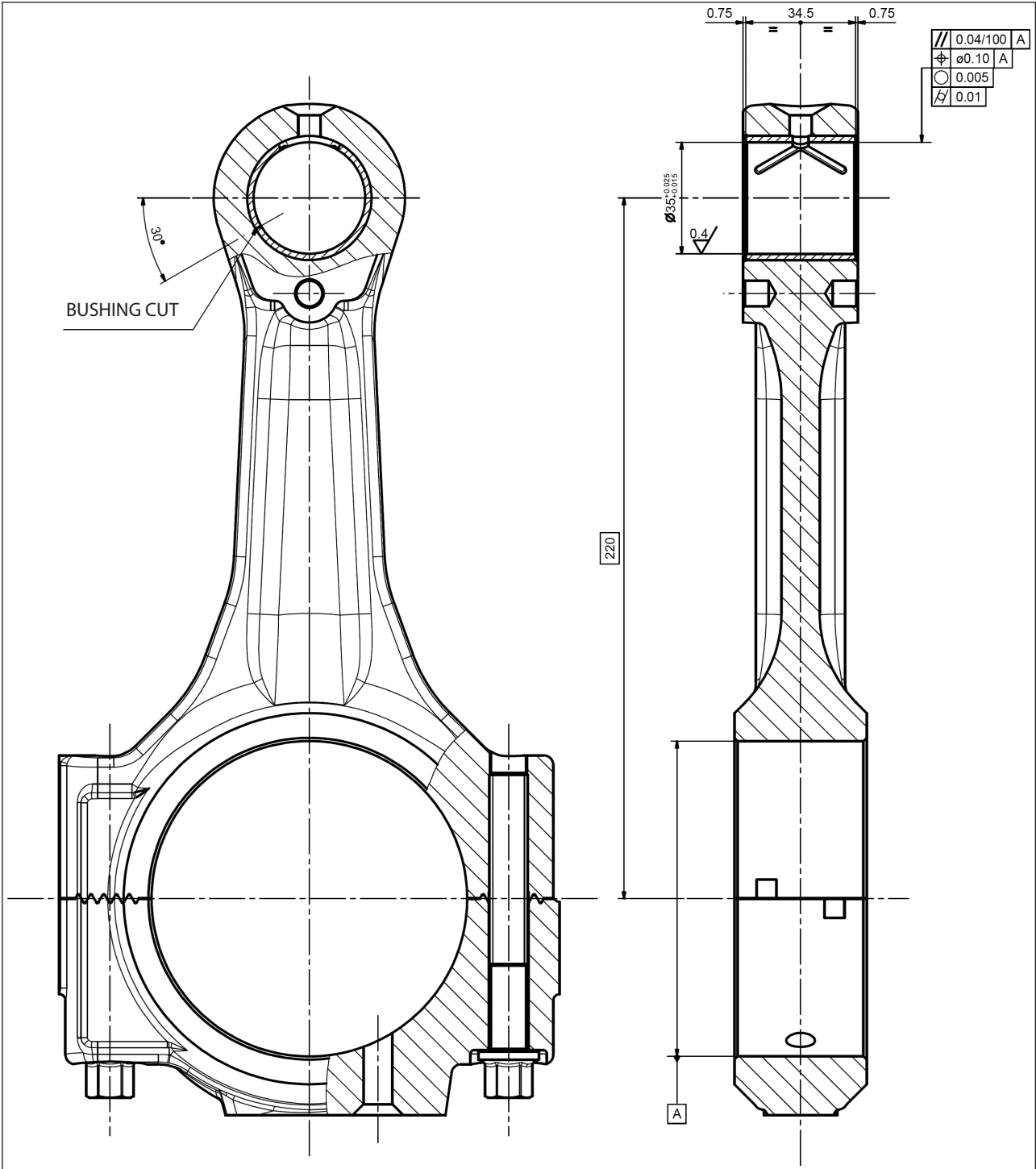

Fig. 169

Sommaire

1	INTRODUCTION	71
1.1	DESCRIPTION DES SYMBOLES	71
2	CONSIGNES DE RÉPARATION	71
2.1	RÉPARATION DE LA PARTIE MÉCANIQUE.....	71
2.1.1	<i>Démontage de la partie mécanique</i>	71
2.1.2	<i>Remontage de la partie mécanique</i>	79
2.1.3	<i>Classes de majorations prévues</i>	89
2.2	RÉPARATION DE LA PARTIE HYDRAULIQUE	89
2.2.1	<i>Désassemblage de la tête - groupes des soupapes</i>	89
2.2.2	<i>Remontage de la tête - ensembles de soupapes</i>	91
2.2.3	<i>Démontage du groupe piston - supports - joints d'étanchéité</i>	95
2.2.4	<i>Montage du groupe piston - supports - joints d'étanchéité</i>	97
2.2.5	<i>Récupération des têtes</i>	100
3	FORCES DE SERRAGE DES VIS	101
4	OUTILS POUR LA RÉPARATION	102
5	VERSIONS SPÉCIALES	102
6	REMPLACEMENT DE LA DOUILLE PIED DE LA BIELLE	102

1 INTRODUCTION

Ce manuel décrit les instructions pour la réparation des pompes de la série LK et doit être attentivement lu et compris avant d'effectuer et de réaliser toute intervention sur la pompe.

Le bon fonctionnement et la durée de la pompe dépendent de l'usage correct et de l'entretien approprié effectué sur celle-ci.

Interpump Group décline toute responsabilité concernant les dommages causés par négligence et inobservation des consignes décrites dans ce manuel.

1.1 DESCRIPTION DES SYMBOLES

Lire attentivement ce qui est indiqué dans ce manuel avant de commencer toute opération.



Signal de Mise en garde



Lire attentivement ce qui est indiqué dans ce manuel avant de commencer toute opération.



Signal de Danger

S'équiper de lunettes de protection.



Signal de Danger

S'équiper de gants de protection avant chaque opération.

2 CONSIGNES DE RÉPARATION



2.1 RÉPARATION DE LA PARTIE MÉCANIQUE

Les opérations de réparation de la partie mécanique doivent être effectuées après avoir éliminé l'huile du carter.

Pour vidanger l'huile, retirer le bouchon de remplissage rep. ①, Fig. 1 puis le bouchon de vidange rep. ②, Fig. 1.

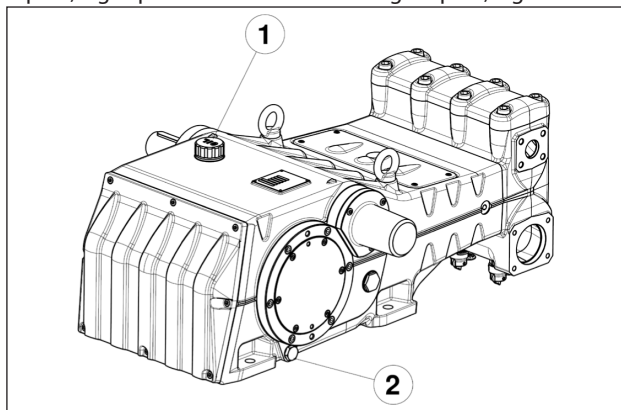

Fig. 1



Verser l'huile usagée dans un récipient spécial et l'éliminer auprès des centres autorisés. Elle ne doit en aucun cas être déversée dans l'environnement.

2.1.1 Démontage de la partie mécanique

La séquence correcte est la suivante :

Vidanger l'huile de la pompe en suivant les explications au parag. 2.1.

Démonter la manette de levage des soupapes de la tête et la tête du carter de pompe, en suivant les explications au parag. 2.2.1 (de Fig. 103 à Fig. 105).

Déposer le couvercle d'inspection supérieur et le couvercle d'inspection inférieur en dévissant les 4+4 vis de fixation en suivant les explications au parag. 2.2.3 (Fig. 139 et Fig. 140). Dégager les joints toriques et les remplacer si nécessaire.

Déposer les trois pistons et les groupes chemises-supports de joint en suivant les explications au parag. 2.2.3 (Fig. 138, Fig. 141 et Fig. 142).

Déposer les trois entretoises anti-éclaboussures et les anneaux anti-éclaboussures, en suivant les explications au parag. 2.2.3 (Fig. 143 et Fig. 144).

Dévisser les goujons de retenue M6 des trois couvercles du joint d'huile (rep. ①, Fig. 2).

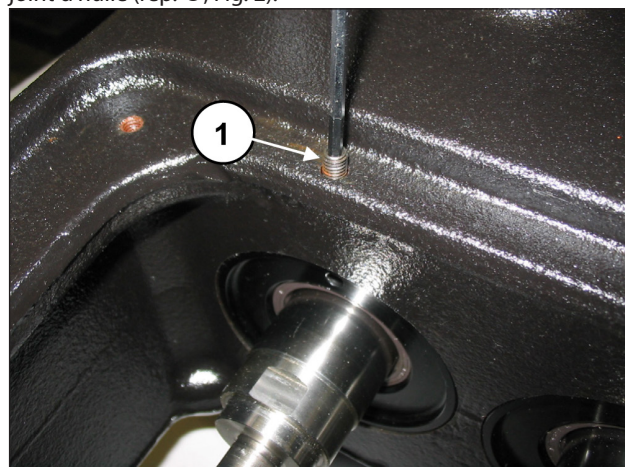

Fig. 2

Visser une barre filetée ou une vis M6 faisant office d'extracteur, dans les orifices prévus à cet effet sur le couvercle du joint d'huile (rep. ①, Fig. 3) et dégager les couvercles du groupe pompe (rep. ①, Fig. 4).

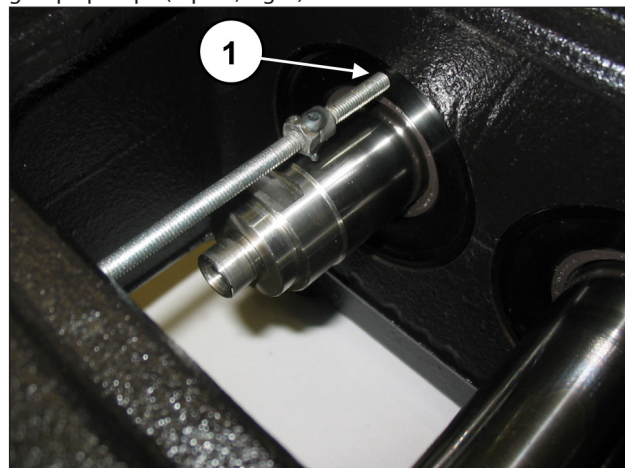

Fig. 3

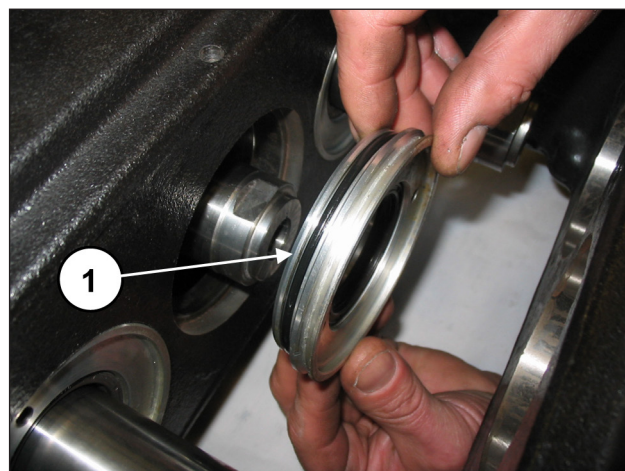

Fig. 4

Extraire la bague d'étanchéité radiale (rep. ①, Fig. 5) et le joint torique extérieur (rep. ①, Fig. 6).

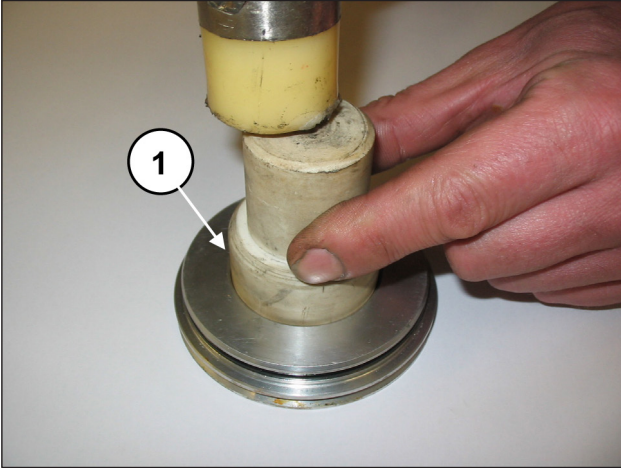

Fig. 5

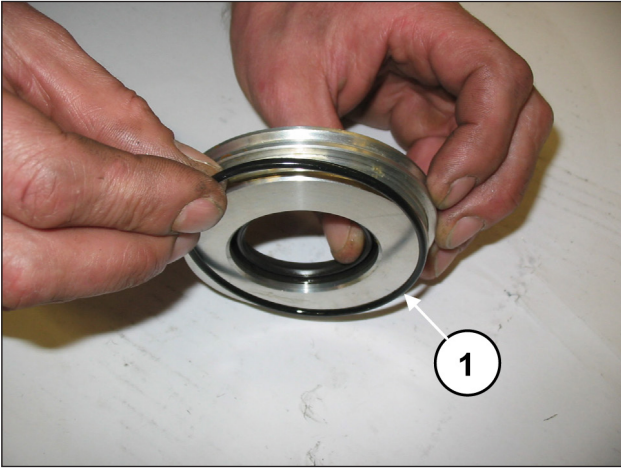

Fig. 6

Déposer la languette de l'arbre PTO (rep. ①, Fig. 7).

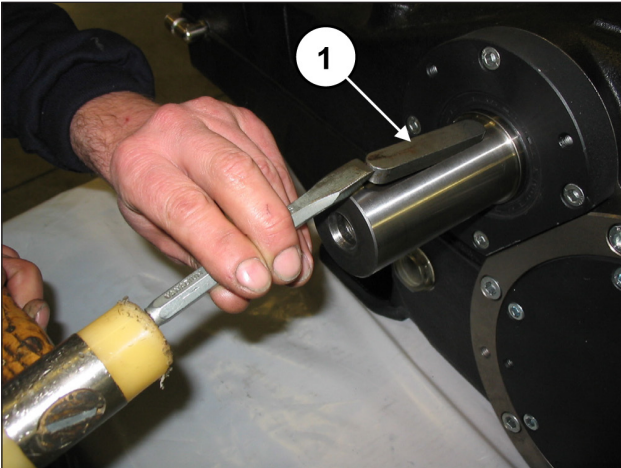

Fig. 7

Dévisser les vis de fixation du couvercle à l'extrémité de l'arbre (rep. ①, Fig. 8) et dégager le couvercle de l'arbre PTO.

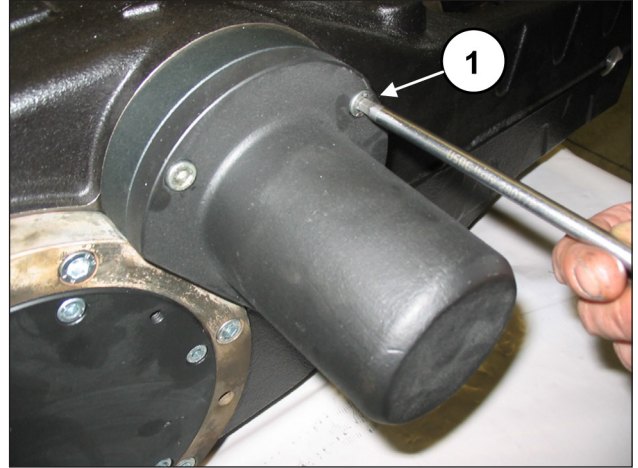

Fig. 8

Dévisser les vis de fixation du couvercle du carter (rep. ①, Fig. 9) et le déposer. Dégager le joint torique et le remplacer si nécessaire.

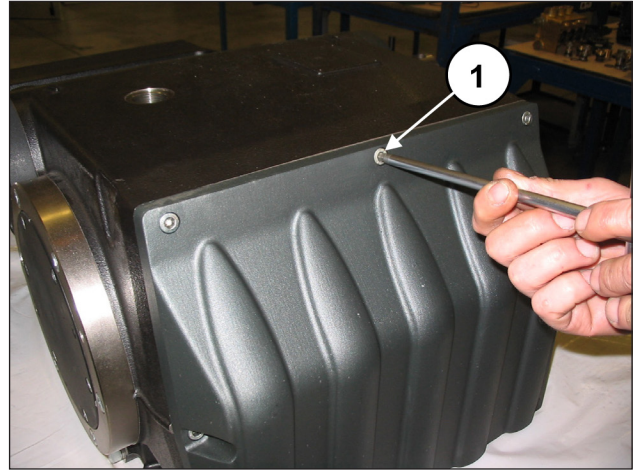

Fig. 9

Démontez ensuite les deux couvercles du coussinet en dévissant les vis correspondantes (rep. ①, Fig. 10). Pour faciliter le démontage, utiliser 2 goujons ou vis M8 (rep. ①, Fig. 11) faisant office d'extracteurs.

Dégager le joint torique et le remplacer si nécessaire.

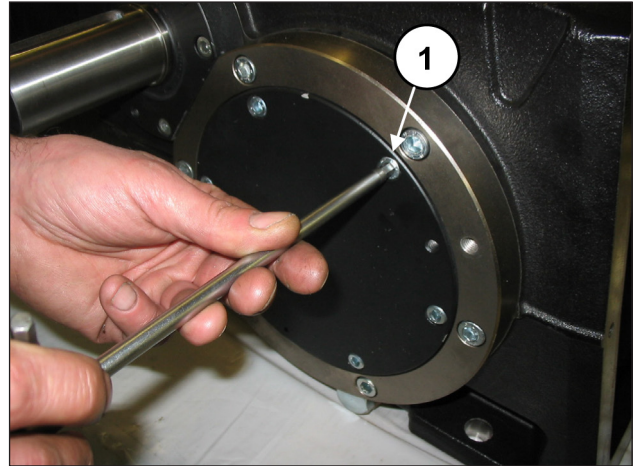

Fig. 10

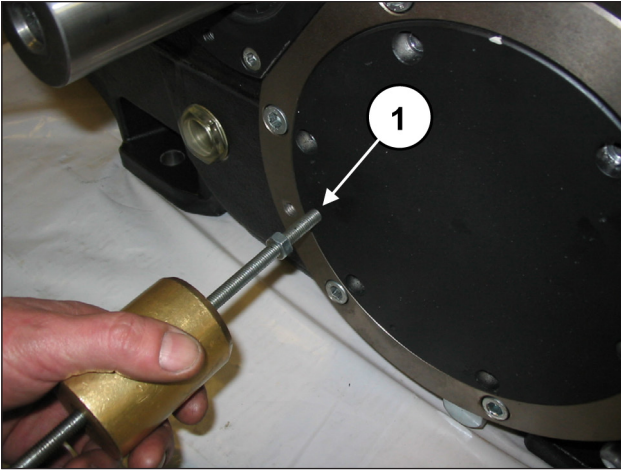

Fig. 11

Insérer une cale sous le corps de la bielle centrale pour empêcher le vilebrequin de tourner (rep. ①, Fig. 12).

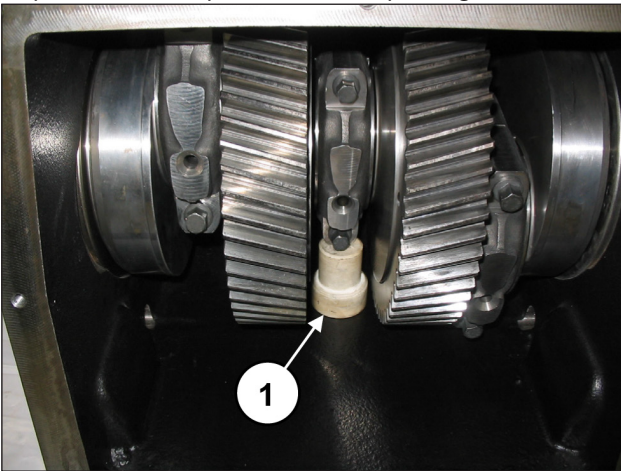

Fig. 12

Dévisser et enlever les vis de fixation du flasque de retenue de la douille, des deux côtés (rep. ①, Fig. 13). Laisser les flasques de retenue de la douille dans leur siège (rep. ①, Fig. 14).

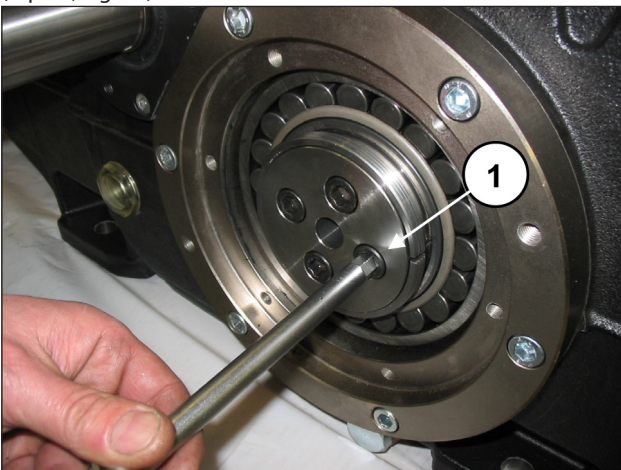

Fig. 13

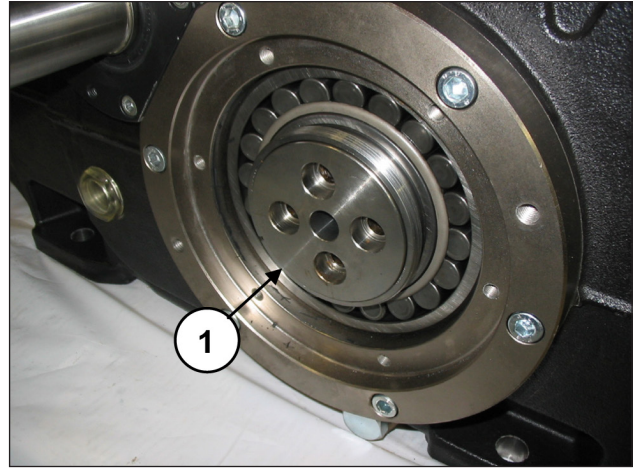

Fig. 14

Sur un côté, visser une bague type SKF KM20 sur la douille de pression (rep. ①, Fig. 15) puis débloquer la douille à l'aide d'un outil à inertie (rep. ①, Fig. 16) sans la dégager. Répéter l'opération de l'autre côté.

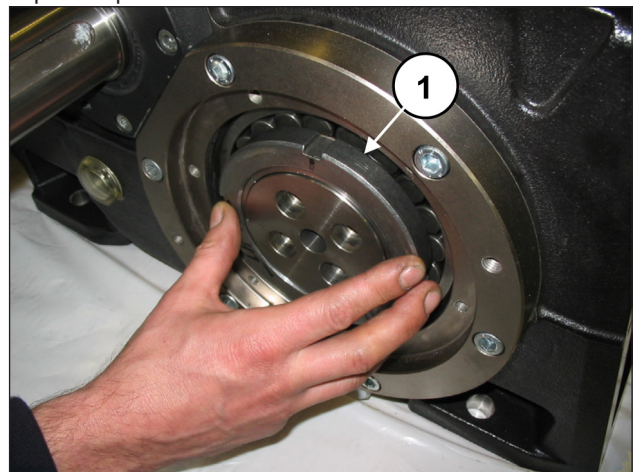

Fig. 15

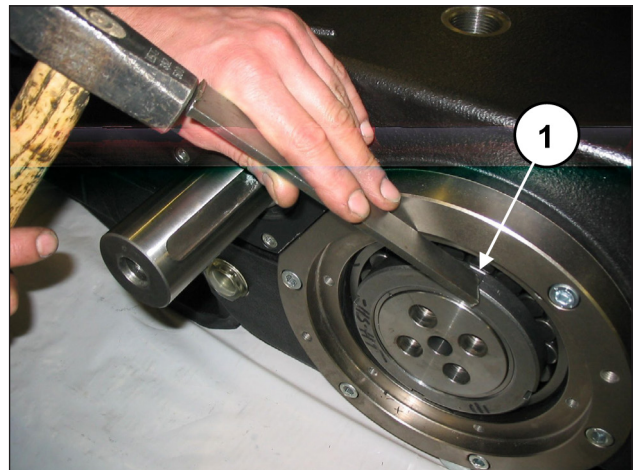

Fig. 16

Retirer la cale sous le corps de la bielle centrale.

Dévisser les vis de la bielle (rep. ①, Fig. 17).

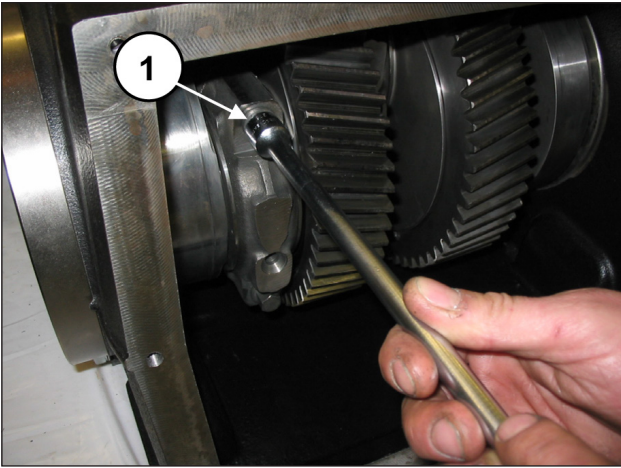

Fig. 17

Démonter les chapeaux de bielle avec les demi-coussinets en prenant note de l'ordre de démontage.



Remonter et accoupler les chapeaux de bielle et leurs demi-bielles dans l'ordre selon lequel ils ont été démontés.

Pour éviter toute erreur possible, les chapeaux et les demi-bielles ont été numérotés sur un côté (rep. ①, Fig. 18).

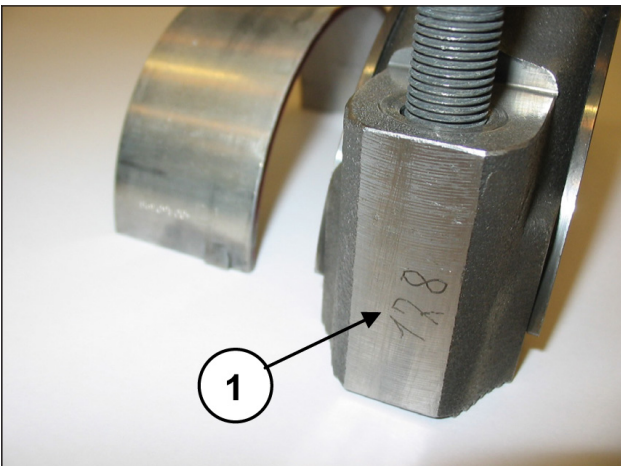
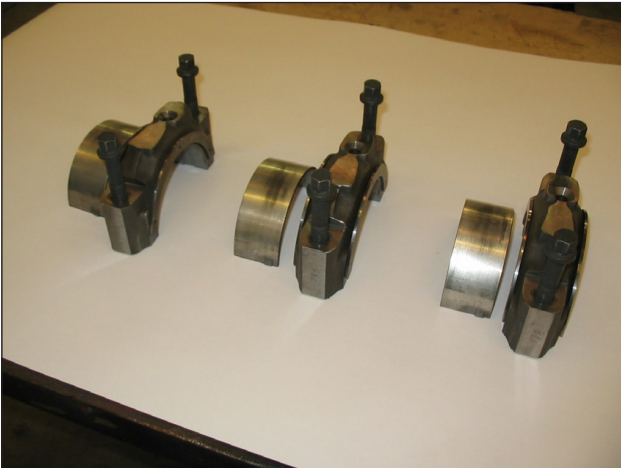

Fig. 18

Faire avancer le plus possible les trois demi-bielles dans la direction de la tête.

Dégager les trois demi-coussinets supérieurs des demi-bielles (rep. ①, Fig. 19).

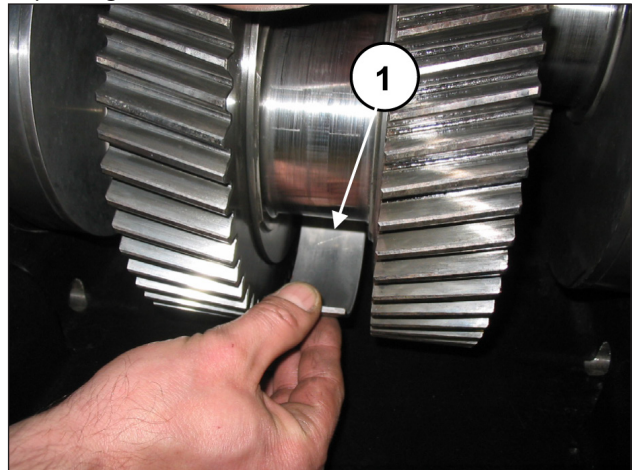

Fig. 19

Déposer les deux douilles de pression (rep. ①, Fig. 20).

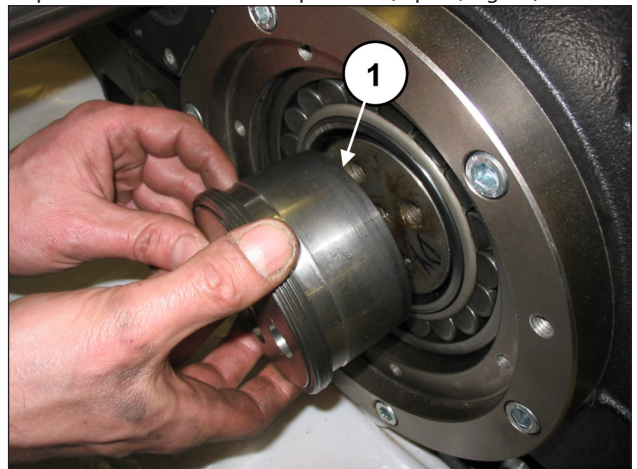

Fig. 20

Désassembler le flasque de retenue de la douille de pression (rep. ①, Fig. 21).

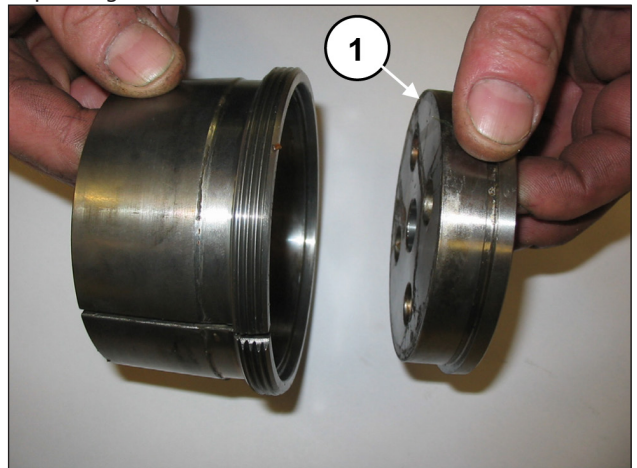

Fig. 21

Dévisser les vis des deux couvercles du support de coussinet (rep. ①, Fig. 22).

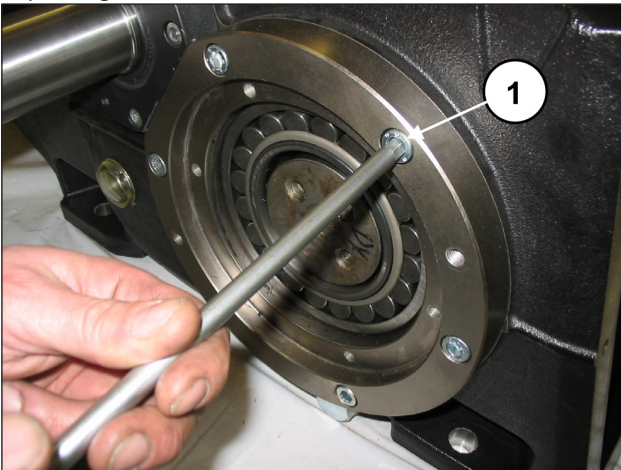

Fig. 22

Poser un axe fileté M16 sur une extrémité du vilebrequin (rep. ①, Fig. 23), soulever ce dernier et extraire le couvercle du support de coussinet avec le joint torique (rep. ①, Fig. 24). Pour faciliter le démontage, utiliser 2 goujons ou vis M10 (rep. ②, Fig. 23) faisant office d'extracteurs. Répéter l'opération de l'autre côté.

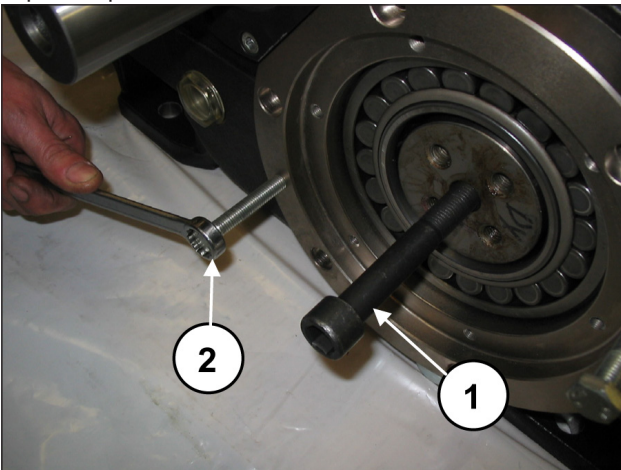

Fig. 23

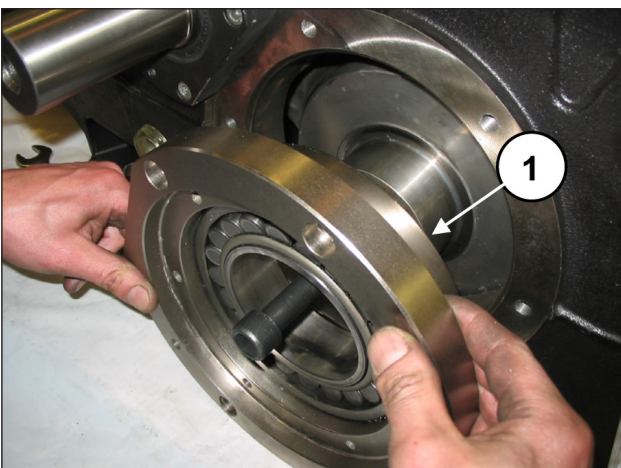

Fig. 24

Poser le vilebrequin sur le fond du carter.

Désassembler le couvercle du support de coussinet du coussinet à l'aide d'un outil à inertie (rep. ①, Fig. 25).

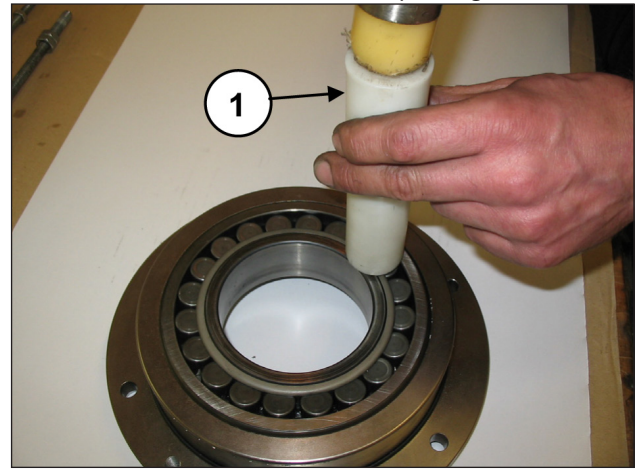

Fig. 25

Desserrer les vis de fixation du couvercle du coussinet de PTO droit et gauche (rep. ①, Fig. 26) et dégager les deux couvercles de l'arbre PTO. Pour faciliter le démontage, utiliser 3 goujons ou vis M8 (rep. ①, Fig. 27) faisant office d'extracteurs.

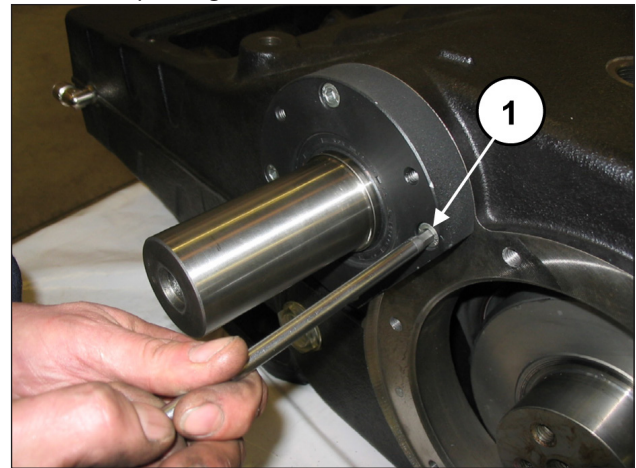

Fig. 26

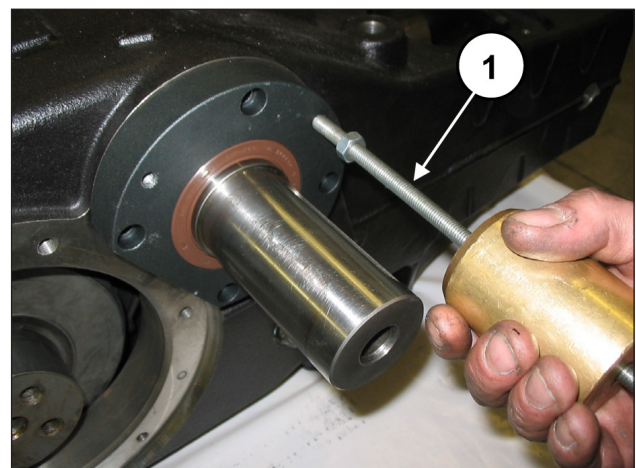

Fig. 27

Extraire la bague d'étanchéité radiale (rep. ①, Fig. 28), le joint torique extérieur (rep. ①, Fig. 29) et le joint torique de l'orifice de lubrification (rep. ①, Fig. 30).

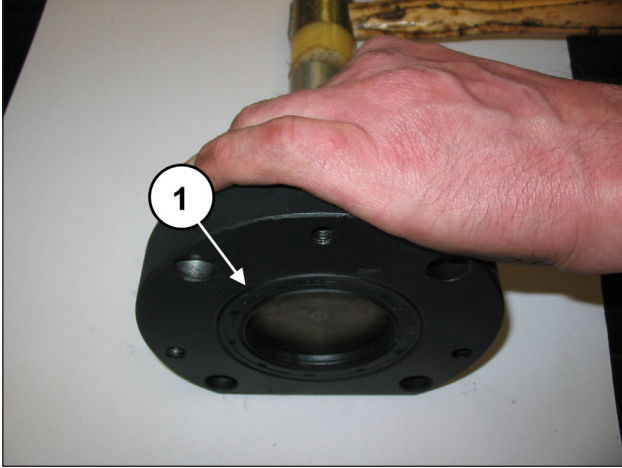

Fig. 28

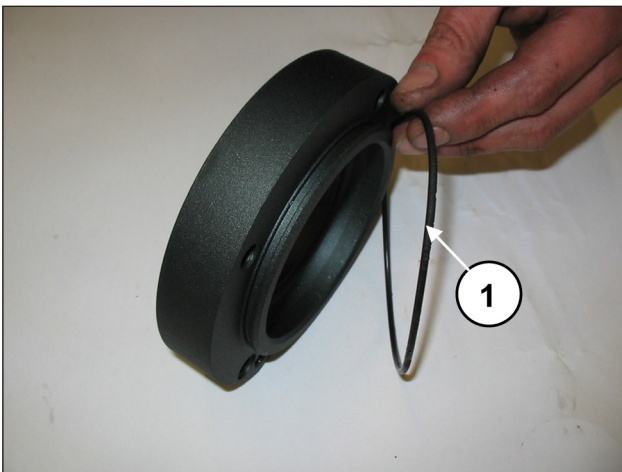

Fig. 29

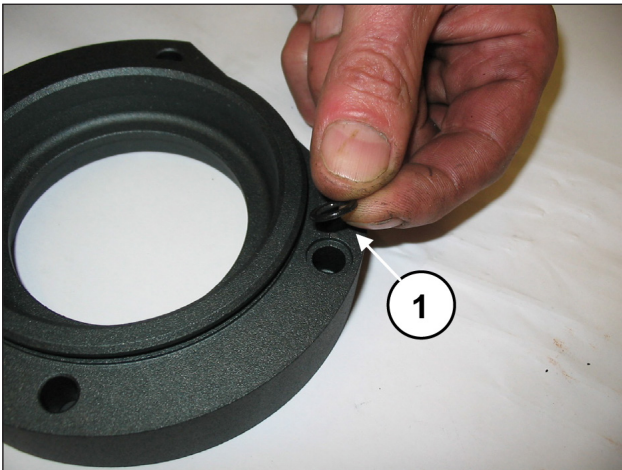

Fig. 30

Faire reculer le plus possible les trois bielles (les amener en contact avec le vilebrequin).

Utiliser un outil à inertie (rep. ①, Fig. 31) pour dégager l'arbre PTO d'un des deux côtés (rep. ①, Fig. 32).

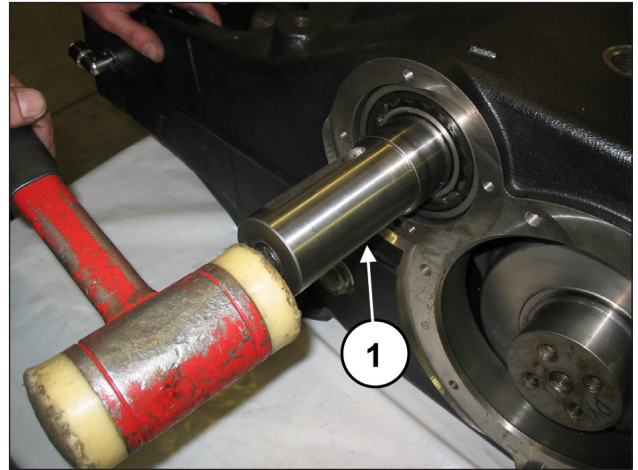

Fig. 31

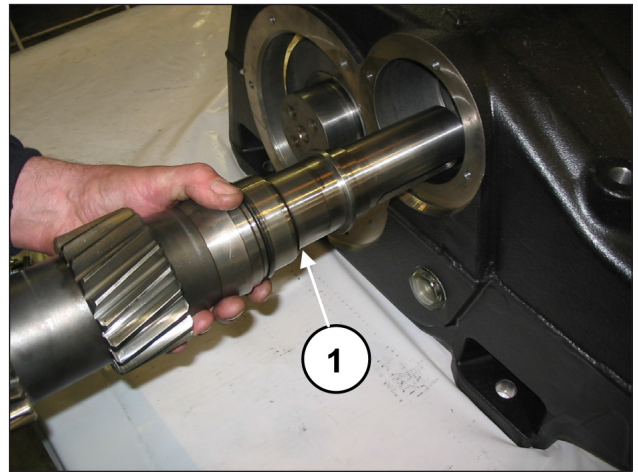

Fig. 32

Dégager les pistes intérieures des coussinets de l'arbre PTO (rep. ①, Fig. 33) et les deux entretoises du coussinet intérieur (rep. ②, Fig. 33).

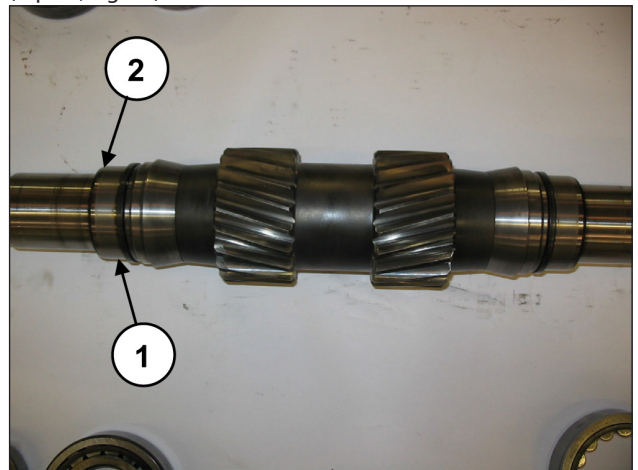

Fig. 33



Remonter les bagues internes et externes des coussinets selon le même ordre de couplage du démontage.

Utiliser une barre suffisamment longue (rep. ①, Fig. 34) et un outil à inertie pour dégager du carter de pompe les bagues des coussinets (rep. ①, Fig. 35), l'entretoise du coussinet extérieur (rep. ①, Fig. 36) et la douille de lubrification des coussinets (rep. ①, Fig. 37).

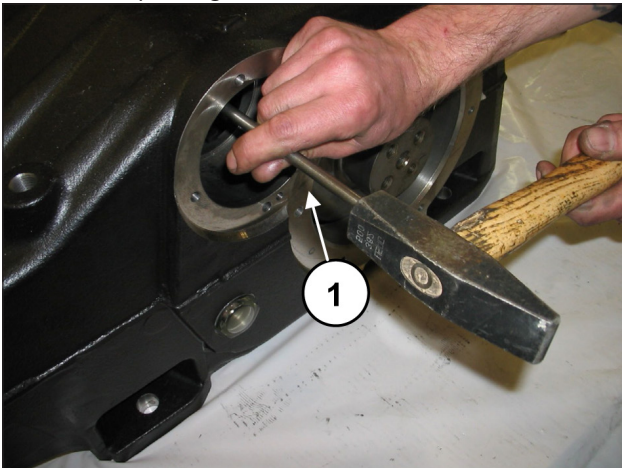

Fig. 34

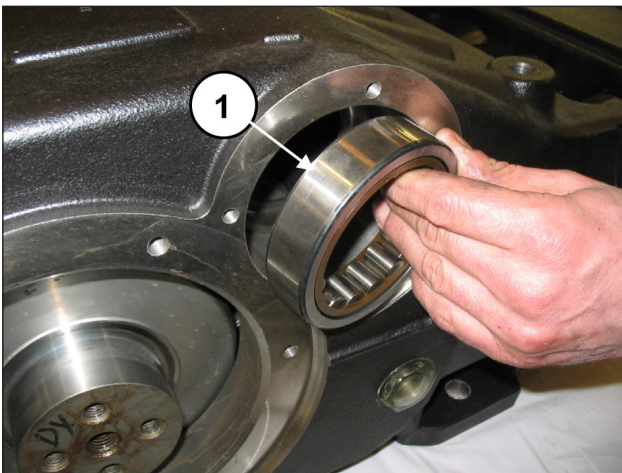

Fig. 35

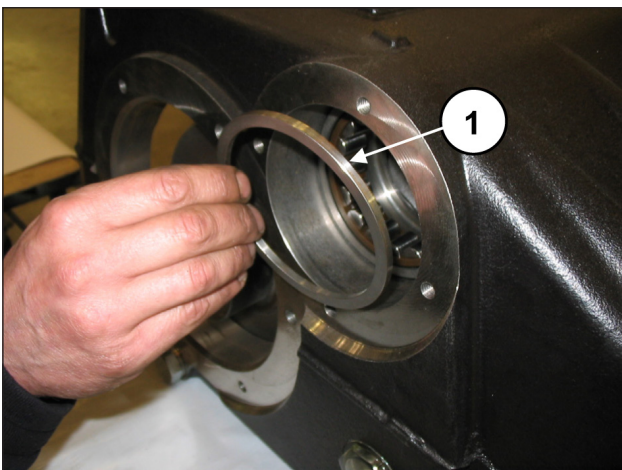

Fig. 36

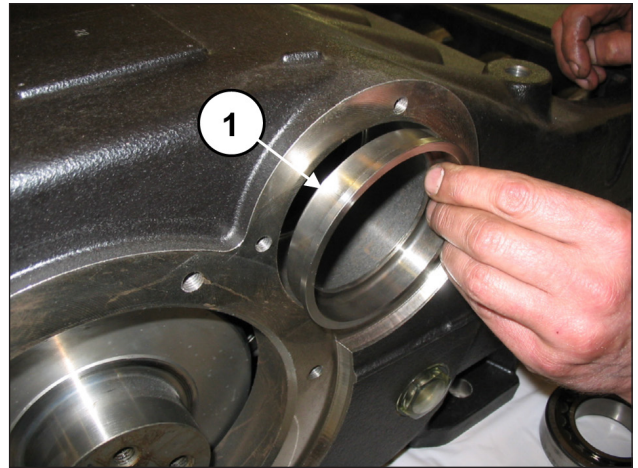

Fig. 37

Faire avancer les demi-bielles dans la direction de la partie hydraulique et les bloquer à l'aide de l'outil (réf. 27566200 (rep. ①, Fig. 38).

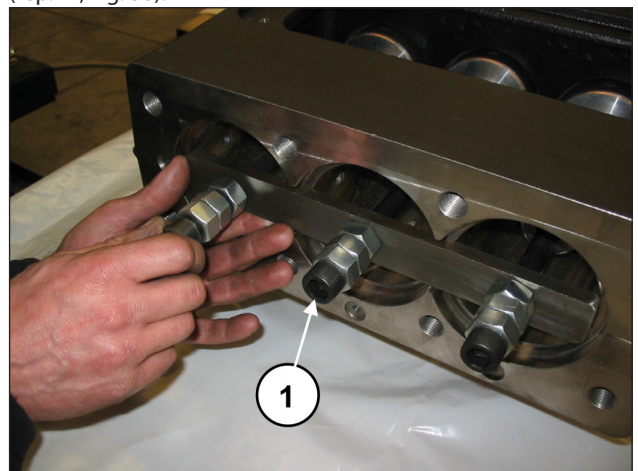

Fig. 38

Dégager le vilebrequin par l'arrière du carter (rep. ①, Fig. 39).

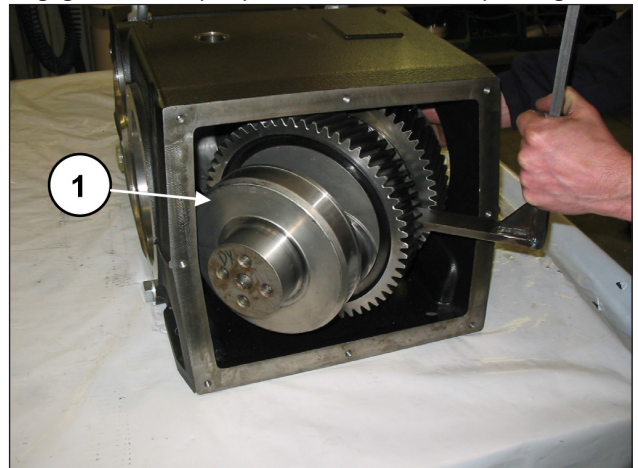

Fig. 39

Dévisser les vis de l'outil réf. 27566200 pour débloquer les bielles (rep. ①, Fig. 40) puis dégager les ensembles bielle-guide de piston par l'ouverture arrière du carter (rep. ①, Fig. 41).

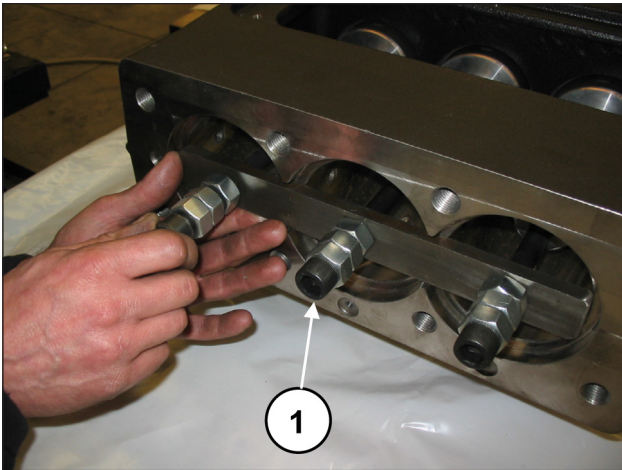

Fig. 40

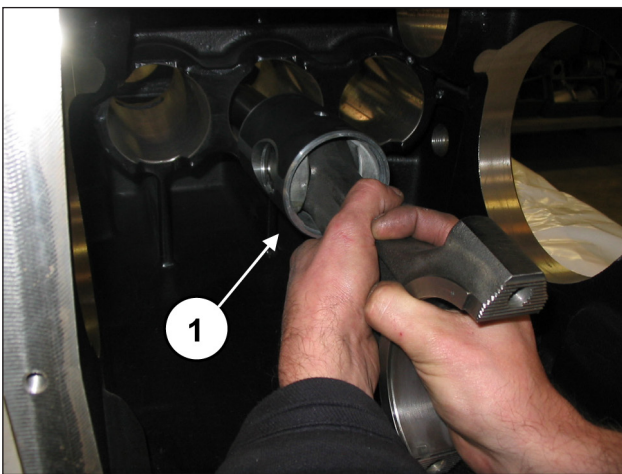

Fig. 41

Accoupler les demi-bielles avec les chapeaux préalablement démontés en suivant la numérotation (rep. ①, Fig. 42).

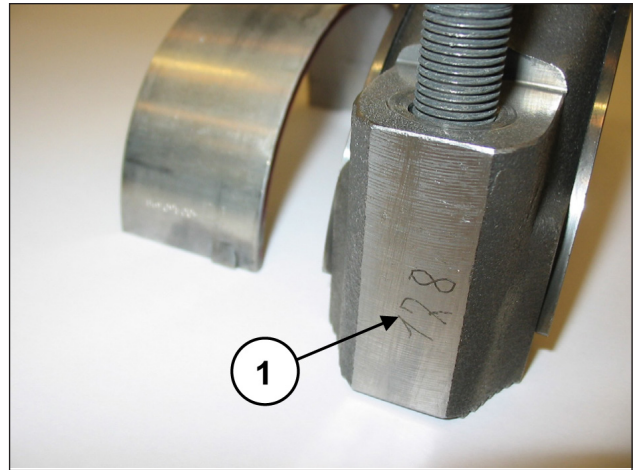
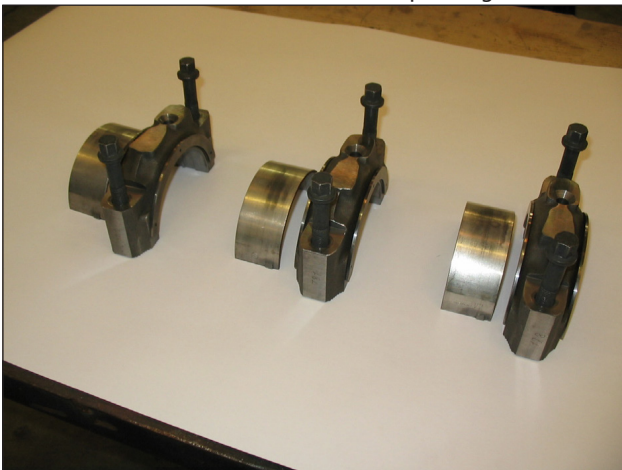

Fig. 42

Déposer les deux anneaux Seeger de retenue de la goupille à l'aide d'un outil approprié (rep. ①, Fig. 43).

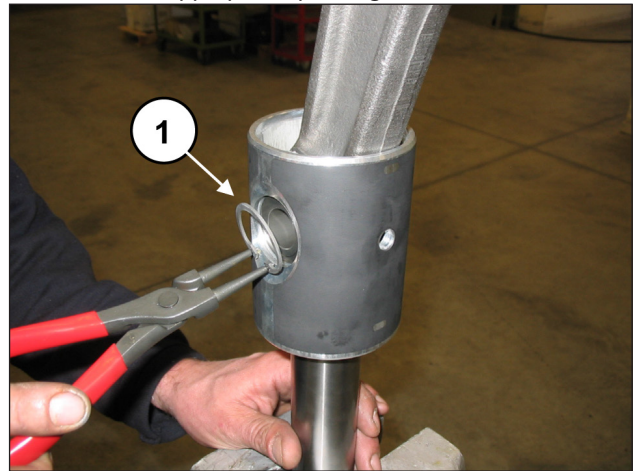

Fig. 43

Dégager la goupille (rep. ①, Fig. 44) et extraire la bielle (rep. ①, Fig. 45).

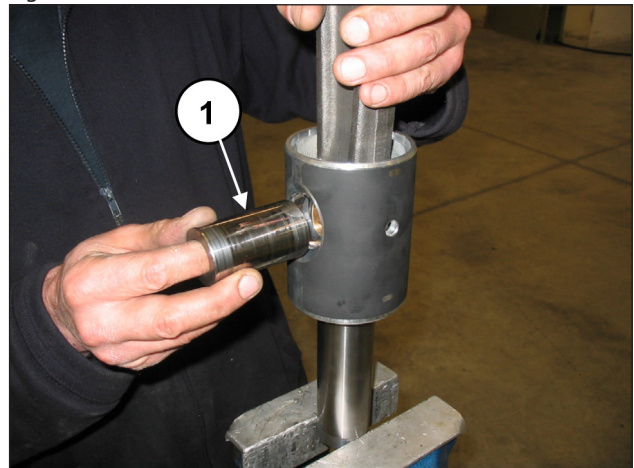

Fig. 44

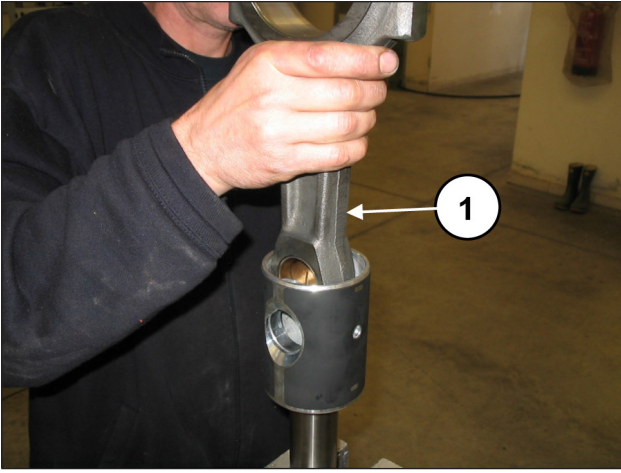

Fig. 45

Pour désassembler la tige du guide de piston, dévisser les vis à tête cylindrique M6 à l'aide d'une clé spéciale (rep. ①, Fig. 46).

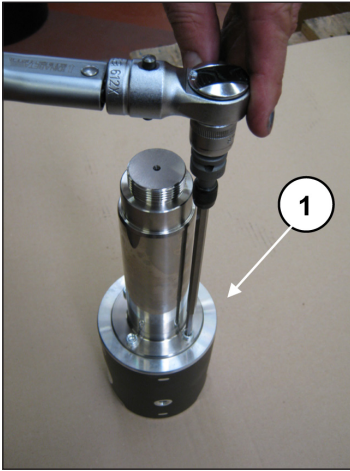

Fig. 46

Compléter le démontage de la partie mécanique en démontant les témoins de niveau d'huile et les œillets.

2.1.2 Remontage de la partie mécanique

Procéder au montage en inversant les opérations du parag. 2.1.1.

La séquence correcte est la suivante :

Remonter les deux témoins de niveau d'huile, les deux bouchons d'évacuation de l'huile et le raccord rapide à 90° (rep. ①, ② et ③ Fig. 47).

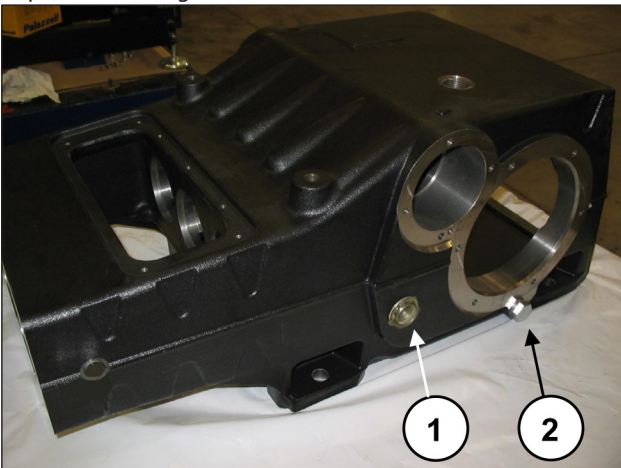

Fig. 47

Assembler la tige au guide de piston.

Insérer la tige du guide de piston dans le logement prévu à cet effet sur le guide de piston (rep. ①, Fig. 48) et le fixer sur ce dernier à l'aide des 4 vis à tête cylindrique M6x20 (rep. ①, Fig. 49).



Fig. 48

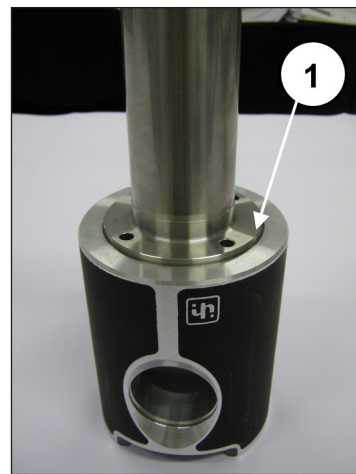

Fig. 49

Bloquer le guide de piston dans un étau à l'aide d'un outil spécial et serrer les vis à l'aide d'une clé dynamométrique (rep. ①, Fig. 50) selon les explications figurant au chapitre 3.

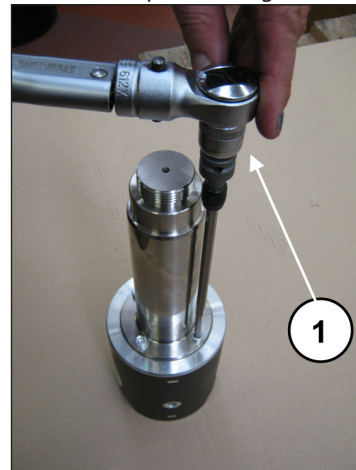

Fig. 50

Insérer la bielle dans le guide de piston (rep. ①, Fig. 45) puis insérer la goupille (rep. ①, Fig. 44). Appliquer les deux Seeger d'appui à l'aide de l'outil approprié (rep. ①, Fig. 43).



Le montage est correct lorsque le pied de bielle, le guide de piston et la goupille tournent sans problèmes.

Désassembler les chapeaux des demi-bielles ; pour les accoupler correctement, suivre la numérotation présente sur un côté (rep. ①, Fig. 42).

Après s'être assuré que le carter est propre, insérer l'ensemble demi-bielle/guide de piston dans les tiges du carter (rep. ①, Fig. 41).



Insérer l'ensemble demi-bielle/guide de piston dans le carter en tournant les demi-bielles de sorte que la numérotation soit visible sur le dessus.

Bloquer les trois groupes à l'aide de l'outil réf. 27566200 (rep. ①, Fig. 40).

Insérer le vilebrequin à travers l'ouverture arrière du carter et le poser sur le fond.



Insérer le vilebrequin dans le carter de sorte que les dents des couronnes soient tournées comme le montre la Fig. 51.

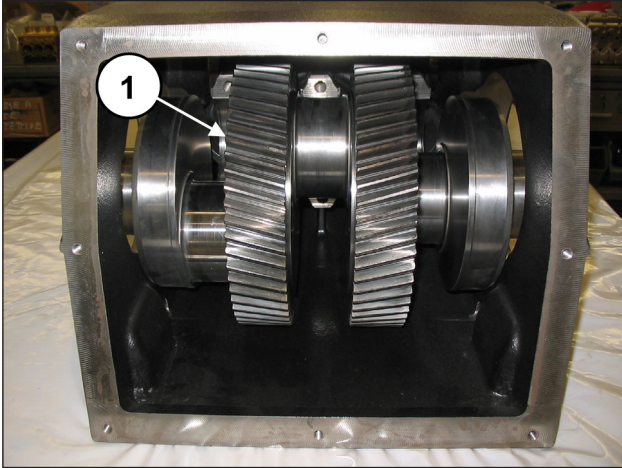

Fig. 51

Prémonter l'arbre PTO : insérer sur l'arbre PTO les 2 bagues intérieures des coussinets (une de chaque côté) (rep. ①, Fig. 52).

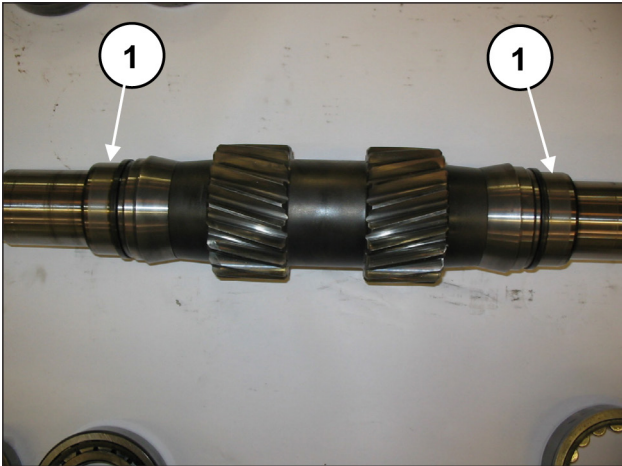

Fig. 52



Remonter les bagues internes et externes des coussinets selon le même ordre de couplage du démontage.

Sur un côté du carter, insérer la douille de lubrification des coussinets (rep. ①, Fig. 53) et une bague extérieure du coussinet (rep. ①, Fig. 54) à l'aide d'un tampon et d'un outil à inertie.

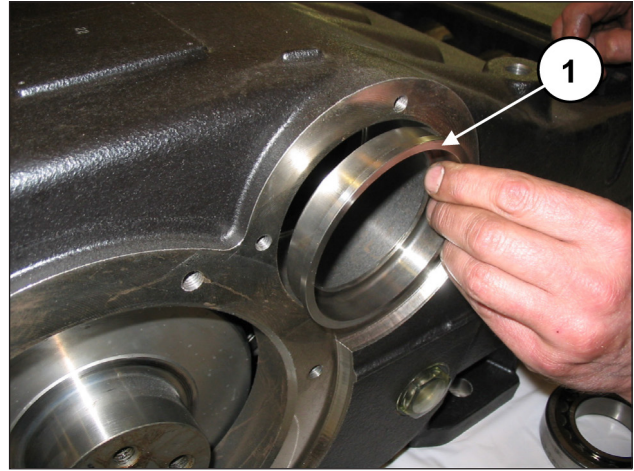

Fig. 53

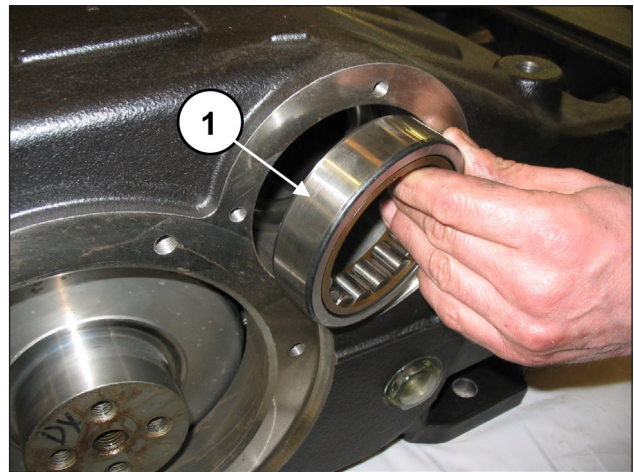

Fig. 54

Déposer l'outil de blocage des bielles réf. 27566200 (rep. ①, Fig. 40) et faire coulisser les bielles en arrière jusqu'à ce qu'elles entrent en contact avec le vilebrequin.

Insérer l'arbre PTO prémonté dans le carter (rep. ①, Fig. 55) en le faisant passer du côté opposé de celui où ont été prémontées la bague extérieure du coussinet et la douille de lubrification des coussinets.



Insérer l'arbre PTO dans le carter de sorte que les dents soient tournées comme le montre la Fig. 55.

Pour faciliter l'insertion de l'arbre PTO dans le coussinet, appliquer une vis M16 à l'extrémité de l'arbre dans le but de soulever ce dernier (rep. ①, Fig. 56).

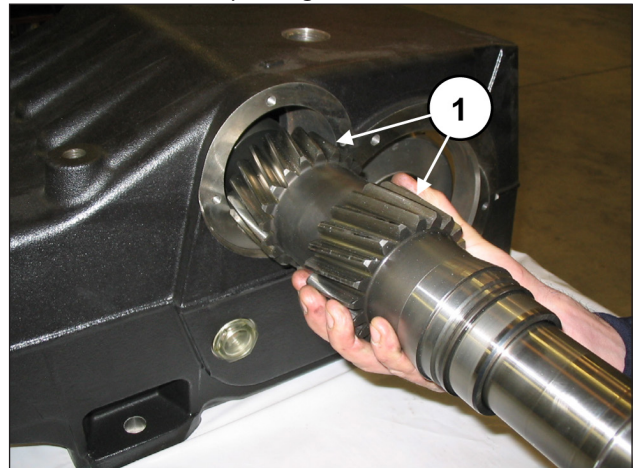

Fig. 55

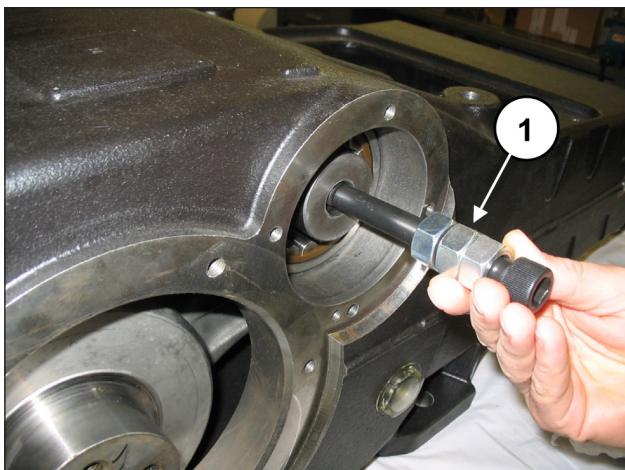

Fig. 56

Sur le côté d'insertion de l'arbre PTO, introduire la douille de lubrification des coussinets (rep. ①, Fig. 57) et une bague extérieure du coussinet (rep. ①, Fig. 58) à l'aide d'un tampon et d'un outil à inertie.



Fig. 57

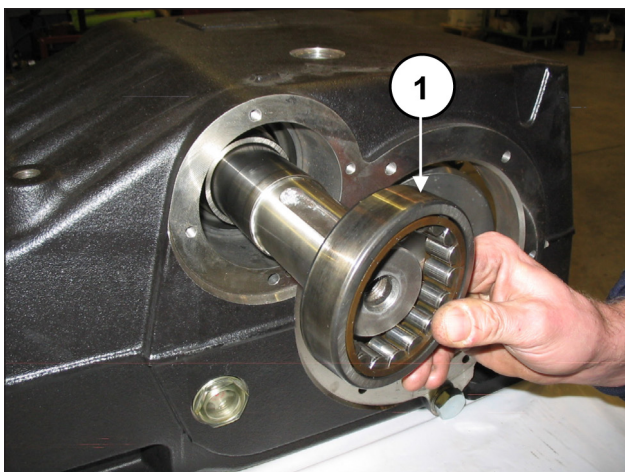

Fig. 58

Insérer les entretoises du coussinet intérieur (rep. ①, Fig. 59) et extérieur (rep. ①, Fig. 60) des deux côtés.



Fig. 59

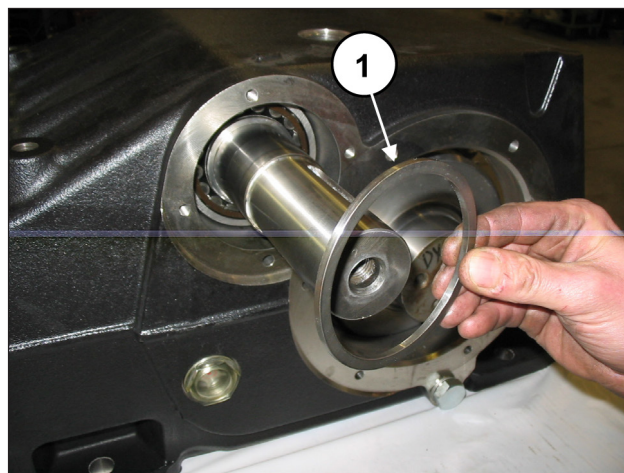

Fig. 60

Insérer la bague intérieure (rep. ①, Fig. 61) et la bague extérieure (rep. ①, Fig. 62) d'un coussinet d'un seul côté de la pompe.

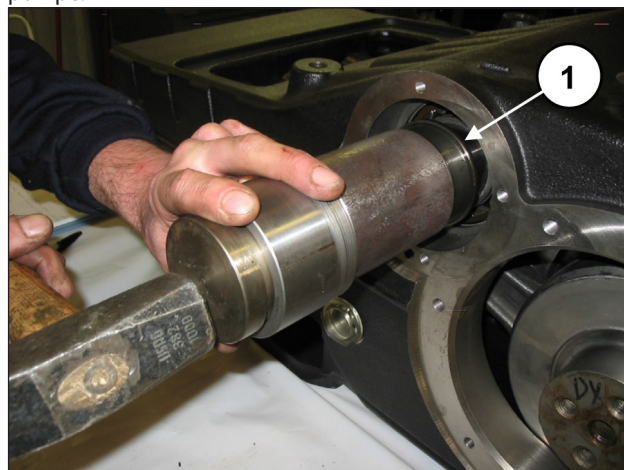

Fig. 61

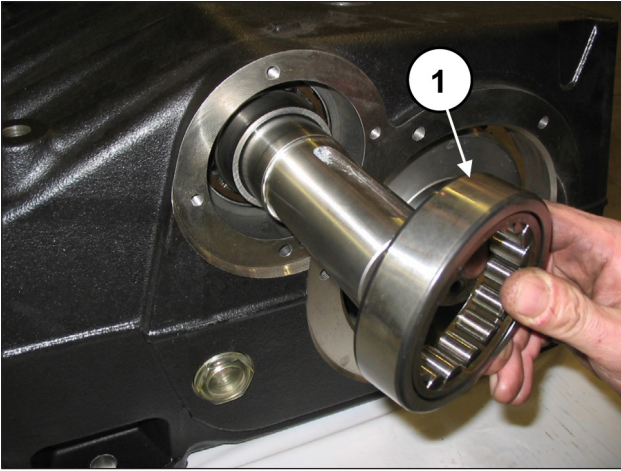

Fig. 62

Prémonter les couvercles du coussinet de PTO droit et gauche :

Insérer le joint d'étanchéité radial dans le couvercle du coussinet de PTO à l'aide de l'outil réf. 27539500 (rep. ①, Fig. 63).

Avant de procéder au montage du joint d'étanchéité radial, vérifier les conditions de la lèvre d'étanchéité. S'il s'avère nécessaire de remplacer le joint, placer le nouveau comme le montre la Fig. 64.



Si l'arbre PTO présente une usure diamétrale au niveau de la lèvre d'étanchéité, pour éviter la rectification, placer le joint en deuxième position, comme le montre la Fig. 64.

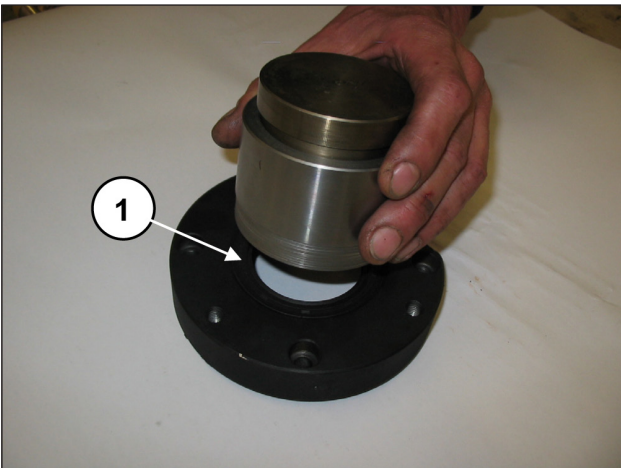

Fig. 63

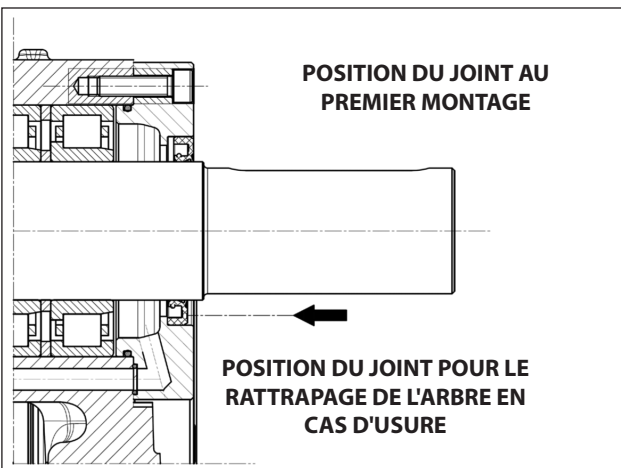

Fig. 64

Poser le joint torique extérieur (rep. ①, Fig. 65) et le joint torique de l'orifice de lubrification (rep. ①, Fig. 66) sur les couvercles du coussinet de PTO.

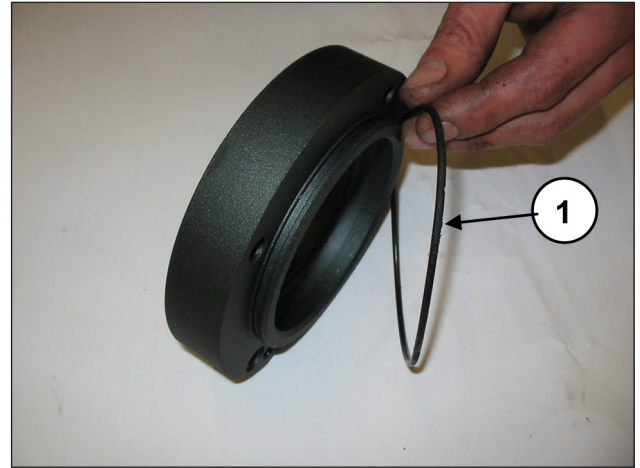

Fig. 65

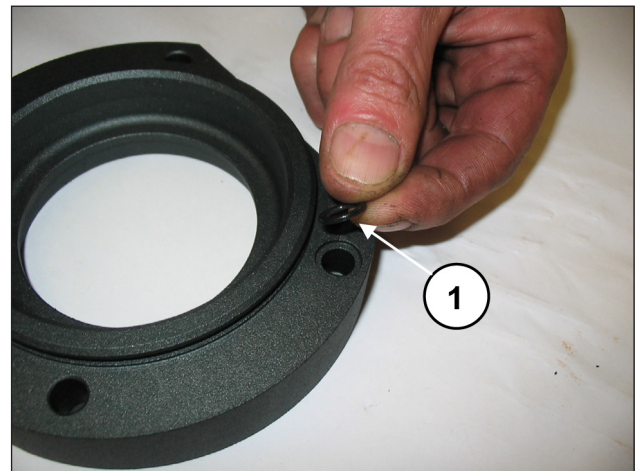

Fig. 66

Monter un premier couvercle de coussinet de PTO (droit ou gauche) sur le carter de pompe (rep. ①, Fig. 67) et le fixer à l'aide de 4 vis M8x30 (rep. ①, Fig. 68).



Faire attention au sens de montage du couvercle. L'orifice de lubrification du couvercle doit se trouver face à l'orifice présent sur le carter.

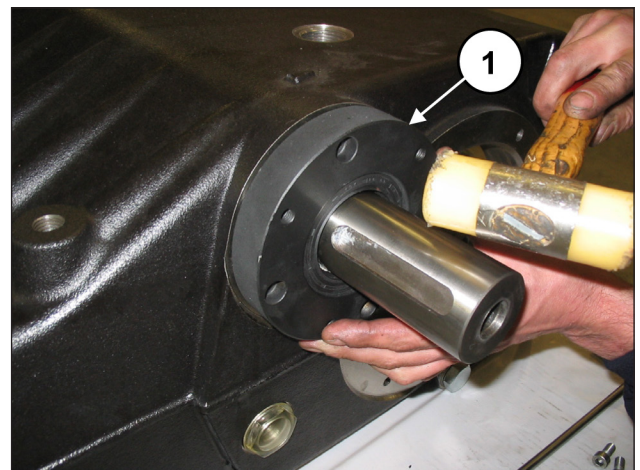

Fig. 67

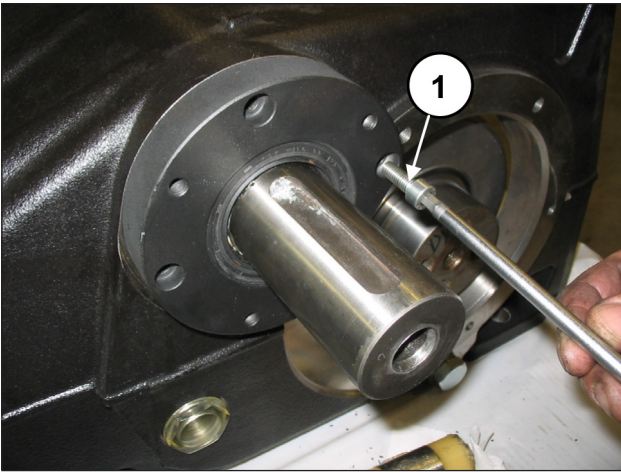

Fig. 68

Répéter les opérations de l'autre côté :
 Insérer la bague intérieure (rep. ①, Fig. 61) et la bague extérieure (rep. ①, Fig. 62) du dernier coussinet.
 Monter l'autre couvercle de coussinet de PTO sur le carter de pompe (rep. ①, Fig. 67) et le fixer à l'aide de 4 vis M8x30 (rep. ①, Fig. 68).
 Serrer les 4+4 vis à l'aide d'une clé dynamométrique, en suivant les explications du chapitre 3.
 Prémonter les deux couvercles de support de coussinet : insérer le coussinet à l'aide d'un outil à inertie (rep. ①, Fig. 69) jusqu'à obtenir une cote de 4±4,5 mm comme le montre la Fig. 70.

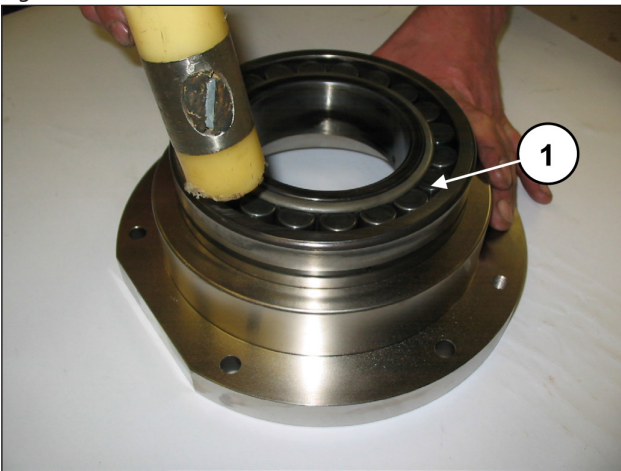

Fig. 69

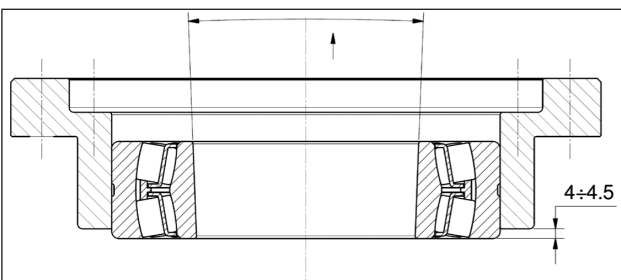

Fig. 70



La bague interne du coussinet Fig. 70 est conique. Vérifier que la conicité va de l'extérieur vers l'intérieur pour recevoir correctement la douille.

Appliquer le joint torique à l'extérieur du couvercle de support de coussinet (rep. ①, Fig. 71).

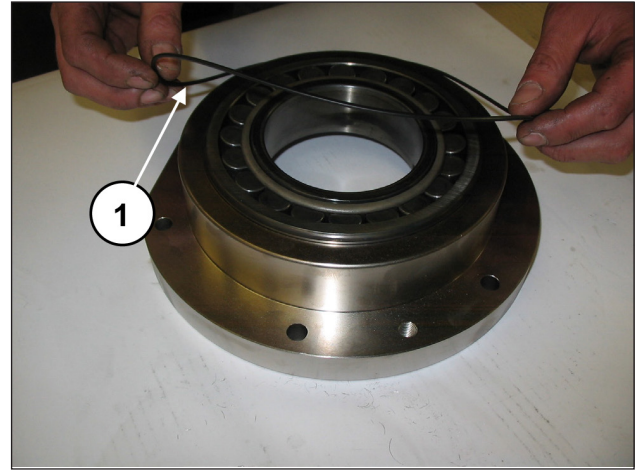

Fig. 71

Répéter l'opération sur l'autre couvercle.
 Bloquer les trois groupes bielle à l'aide de l'outil réf. 27566200 (rep. ①, Fig. 40).
 Poser deux axes filetés M16 à l'extrémité du vilebrequin, soulever ce dernier (rep. ①, Fig. 72) et insérer le couvercle du support de coussinet avec le coussinet et le joint torique (rep. ①, Fig. 73) à l'aide d'un outil à inertie. Répéter l'opération de l'autre côté.

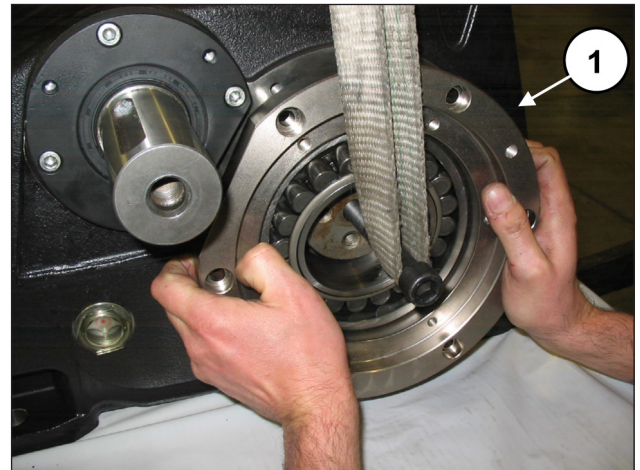

Fig. 72

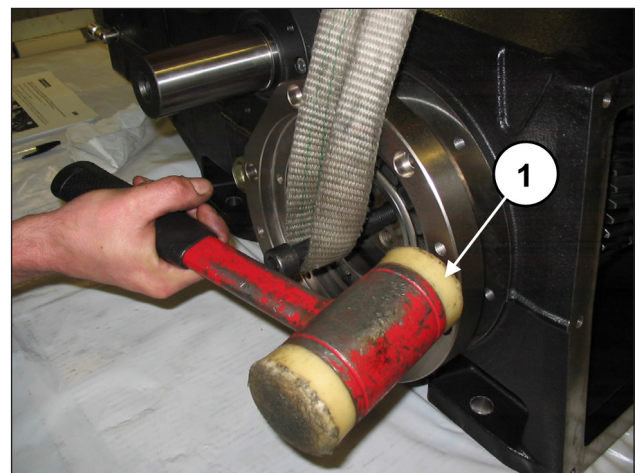

Fig. 73

Visser les couvercles de support de coussinet à l'aide de 6+6 vis M10x30 (rep. ①, Fig. 74).
Serrer les vis à l'aide d'une clé dynamométrique, en suivant les explications du chapitre 3.

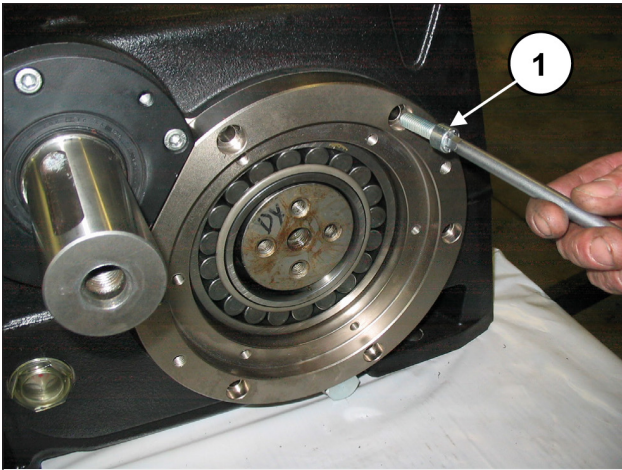

Fig. 74

Insérer une partie des deux douilles de pression tout en soulevant le vilebrequin à l'aide de l'axe M16 préalablement monté (rep. ①, Fig. 75).

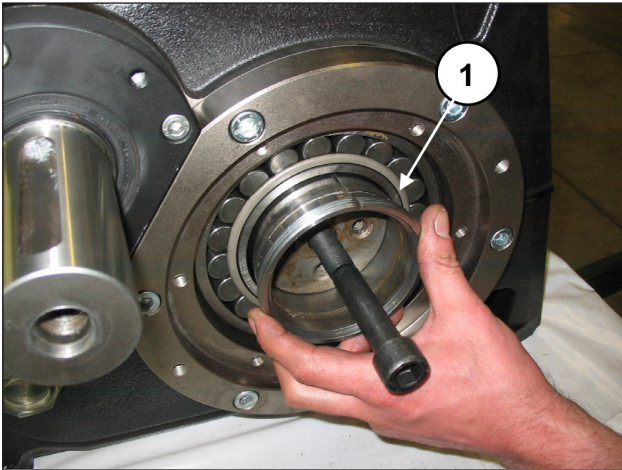

Fig. 75

Pousser à fond la douille de pression sur le vilebrequin (rep. ①, Fig. 76 e Fig. 77) à l'aide d'un outil à inertie et d'un tampon.

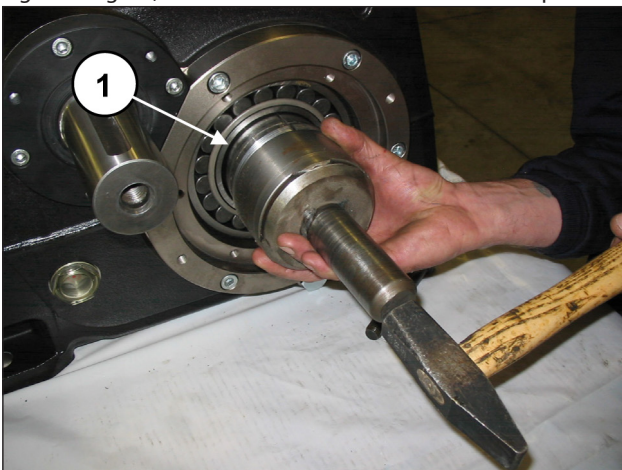

Fig. 76

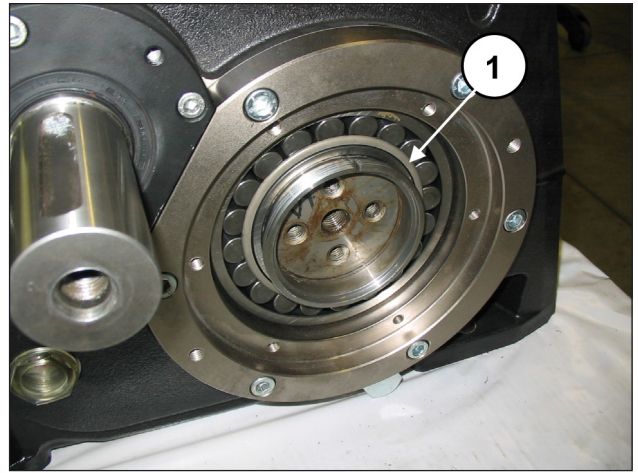

Fig. 77



Installer la douille de pression à sec (sans huile ni lubrifiant).

Insérer la douille jusqu'à ce que la piste extérieure (conique) s'accouple parfaitement avec la piste intérieure du coussinet. Durant la pose, s'assurer que le coussinet reste en contact avec la bague d'appui du vilebrequin.

Répéter l'opération de l'autre côté.

Insérer les flasques de retenue de la douille dans les douilles coniques (rep. ①, Fig. 78).

Poser une vis M16 d'une longueur suffisante (35-40 mm) dans l'orifice M16 du vilebrequin et visser jusqu'à ce que le flasque atteigne la douille (rep. ①, Fig. 79). Ne pas serrer la vis.

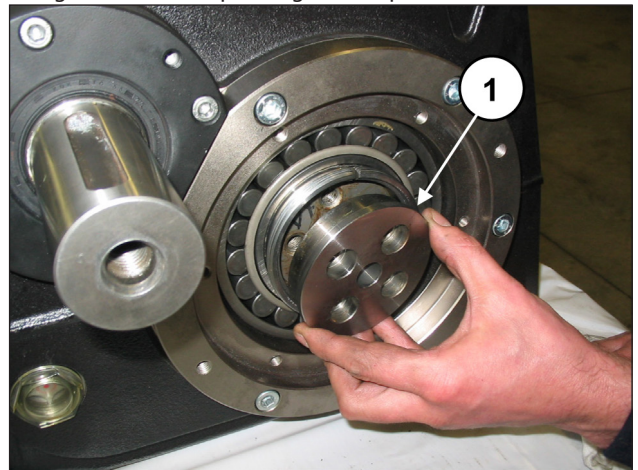

Fig. 78

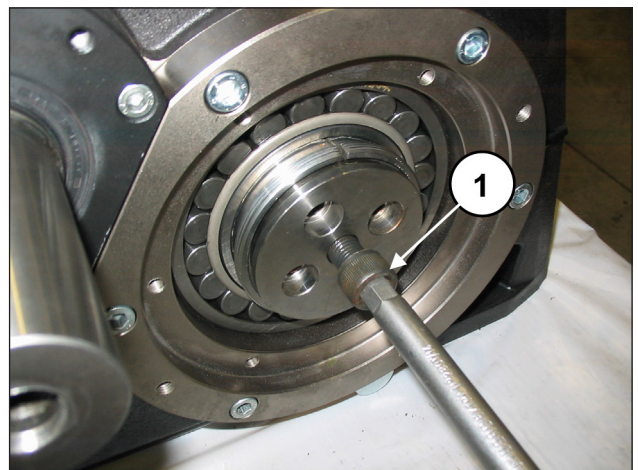

Fig. 79

Répéter l'opération de l'autre côté.

Déposer l'outil de blocage des bielles réf. 27566200 (rep. ①, Fig. 40).

Insérer les demi-coussinets supérieurs entre les bielles et le vilebrequin (rep. ①, Fig. 80).



Pour monter correctement les demi-coussinets, s'assurer que la languette de repère des demi-coussinets se trouve dans son logement sur la demi-bielle (rep. ①, Fig. 81).

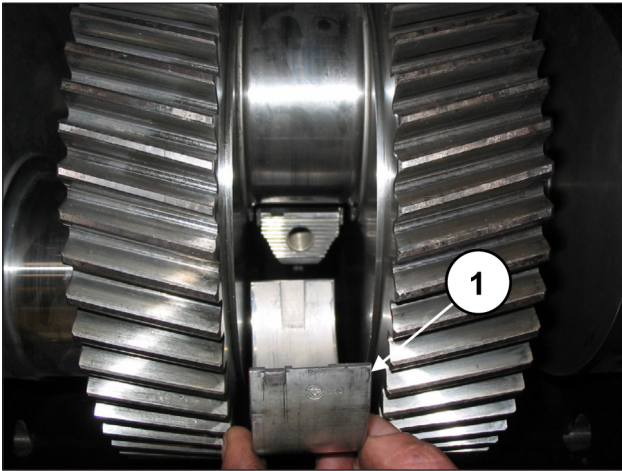

Fig. 80

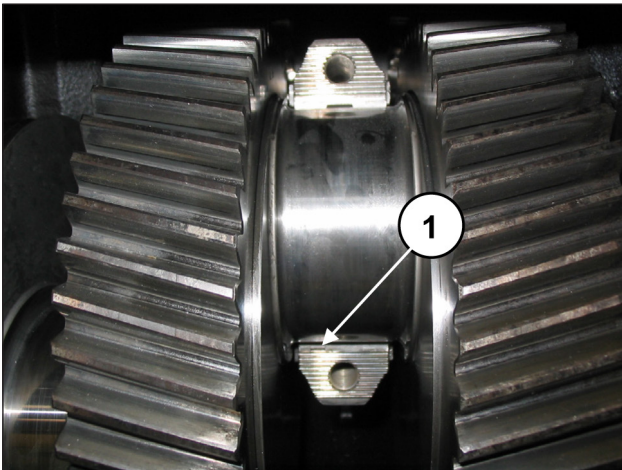

Fig. 81

Assembler les demi-coussinets inférieurs aux chapeaux (rep. ①, Fig. 82) en s'assurant que la languette de repère des demi-coussinets se trouve dans son logement sur le chapeau (rep. ②, Fig. 82).

Fixer les chapeaux sur les demi-bielles à l'aide des vis M12x1,25x87 (rep. ①, Fig. 83).

Serrer les vis à l'aide d'une clé dynamométrique, en suivant les explications du chapitre 3 ; serrer les vis au couple préconisé simultanément.



Faire attention au sens de montage des chapeaux. La numérotation doit être tournée vers le haut.

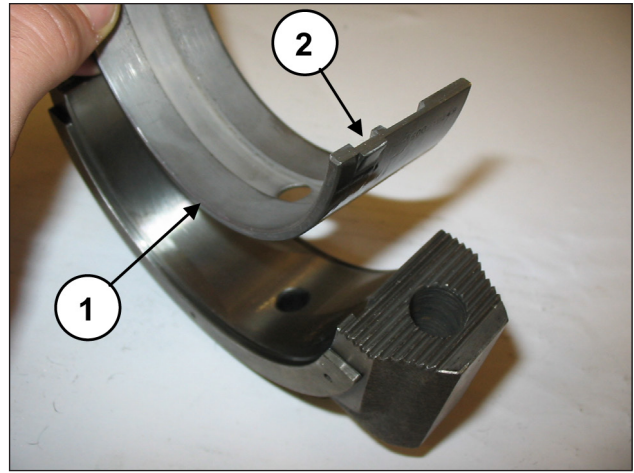

Fig. 82

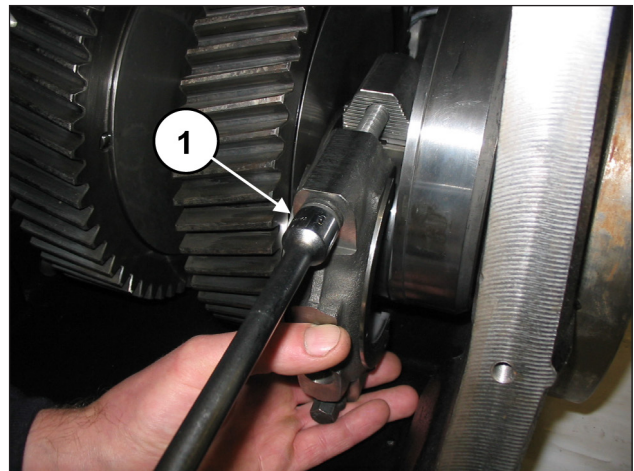

Fig. 83



Une fois l'opération terminée, s'assurer que les bielles présentent un jeu axial dans les deux directions.

Insérer une cale sous le corps de la bielle centrale pour empêcher le vilebrequin de tourner (rep. ①, Fig. 84).

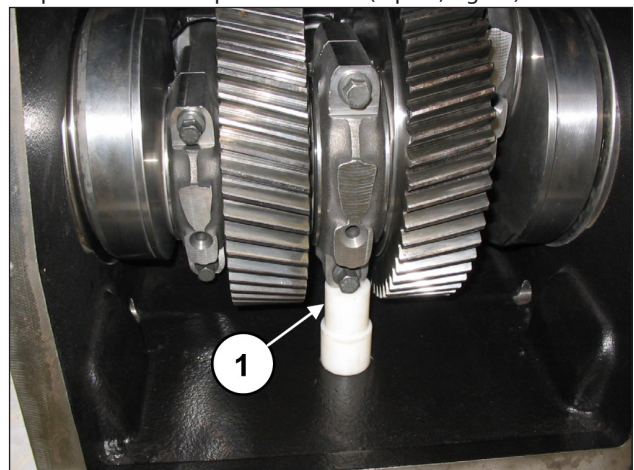

Fig. 84

Mesurer la cote « X » indiquée Fig. 85 entre la douille conique et le coussinet de vilebrequin.

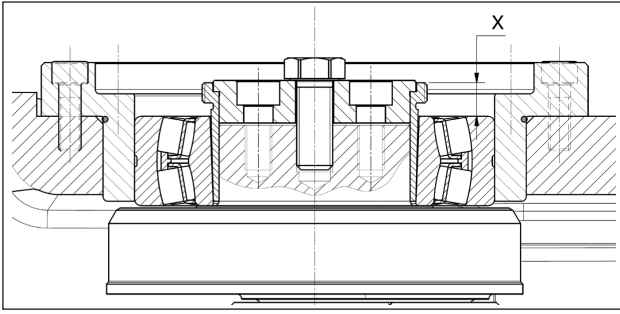

Fig. 85

Visser la vis M16 de sorte à déterminer une réduction de la cote « X » comprise entre 0,7 et 0,8 mm (Fig. 86).

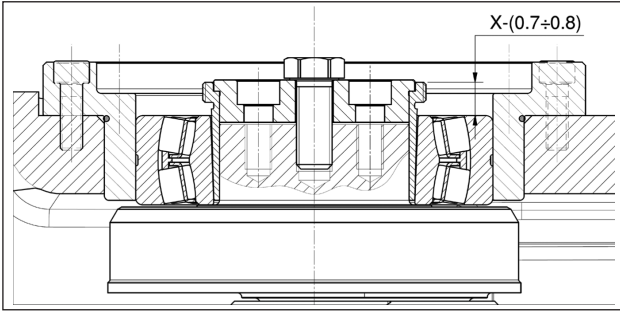

Fig. 86

Répéter l'opération de l'autre côté.

Déposer la vis M16 du vilebrequin.

Visser les deux flasques de retenue de la douille sur le vilebrequin à l'aide de 4+4 vis M12x25 (rep. ①, Fig. 88).



Appliquer LOCTITE 243 sur le filetage des vis M12x25 (rep. ①, Fig. 87).

Serrer les vis à l'aide d'une clé dynamométrique, en suivant les explications du chapitre 3.

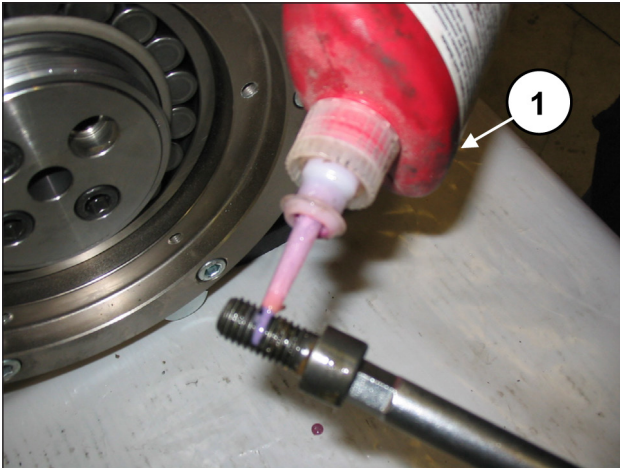

Fig. 87

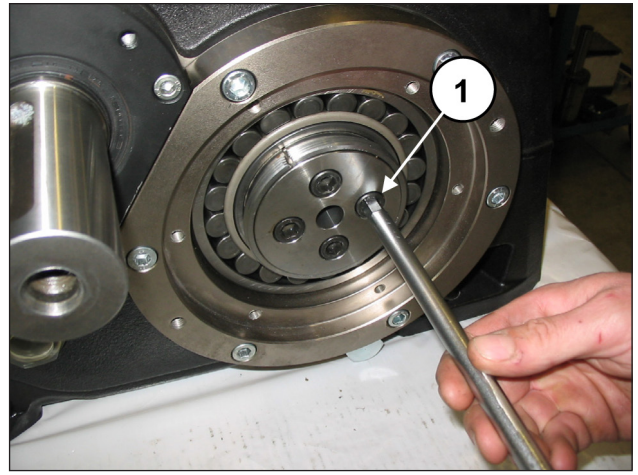

Fig. 88

Retirer la cale anti-rotation sous le corps de la bielle centrale. Monter les deux couvercles de coussinet (avec leur joint torique) (rep. ①, Fig. 89) à l'aide de 6+6 vis M8x20 (rep. ①, Fig. 90).

Serrer les vis à l'aide d'une clé dynamométrique, en suivant les explications du chapitre 3.

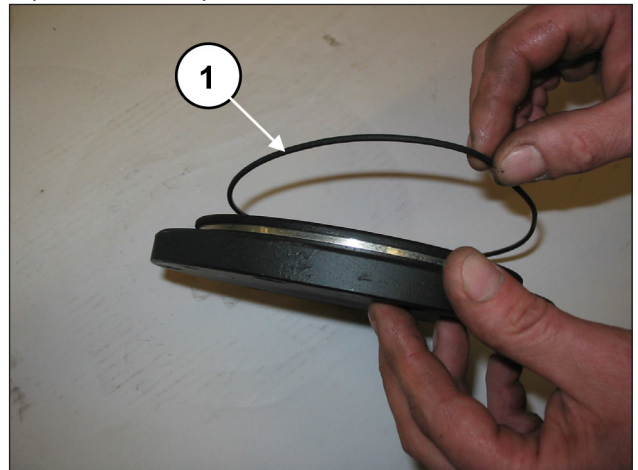

Fig. 89

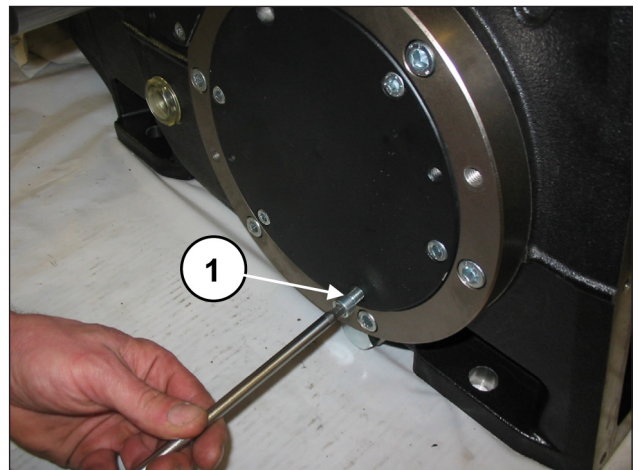

Fig. 90

Insérer le joint torique dans le couvercle arrière (rep. ①, Fig. 91) et le fixer au carter à l'aide de 10 vis M8x20 (rep. ①, Fig. 92).

Serrer les vis à l'aide d'une clé dynamométrique, en suivant les explications du chapitre 3.

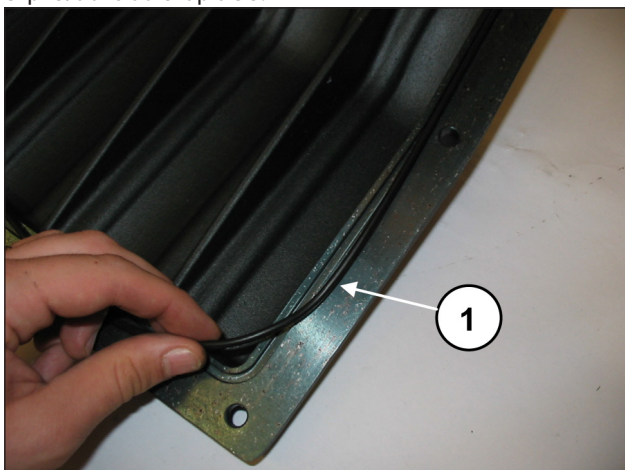

Fig. 91

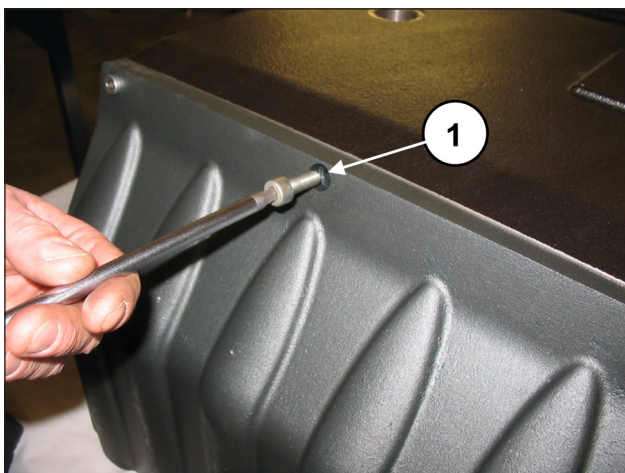

Fig. 92

Monter le joint d'étanchéité radial sur le couvercle du joint d'huile (rep. ①, Fig. 93) à l'aide d'un tampon réf. 27910900.

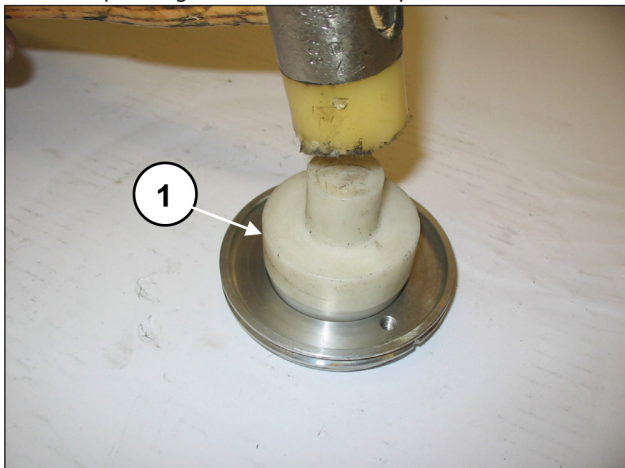

Fig. 93

Placer le joint torique (rep. ①, Fig. 94) dans le siège du couvercle du joint d'huile.

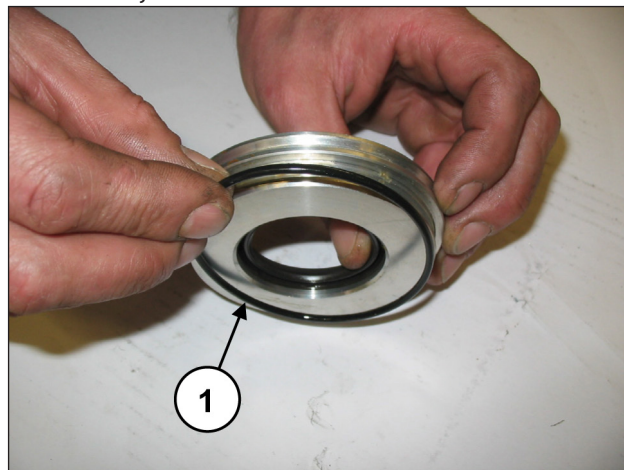

Fig. 94

Insérer le groupe monté dans le logement prévu à cet effet sur le carter et s'assurer que le couvercle s'emboîte complètement dans le siège (rep. ①, Fig. 95) en ayant soin de ne pas endommager la lèvre du joint d'étanchéité radial. Visser les couvercles du joint d'huile à l'aide de 2 goujons M6x30 (rep. ①, Fig. 96).

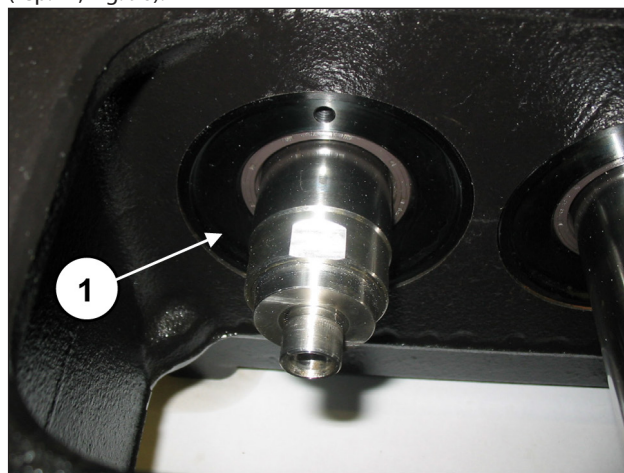

Fig. 95

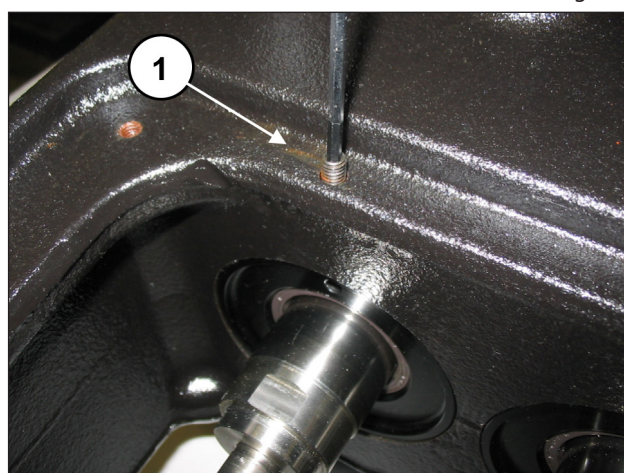

Fig. 96

Serrer les vis à l'aide d'une clé dynamométrique, en suivant les explications du chapitre 3.

Placer les joints anti-éclaboussures et leur entretoise dans le logement sur la tige du guide piston (rep. ①, Fig. 97 et Fig. 98).

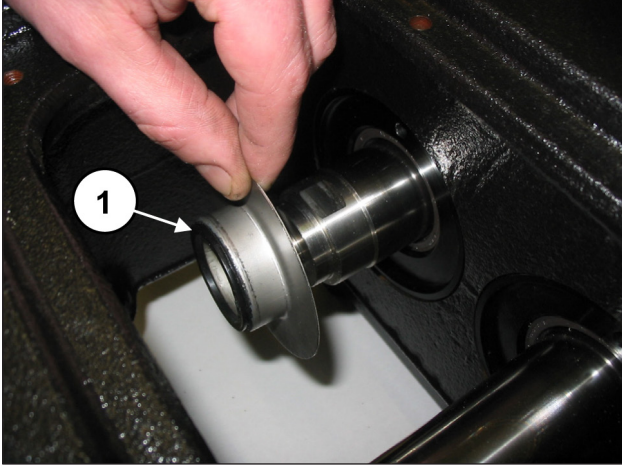

Fig. 97

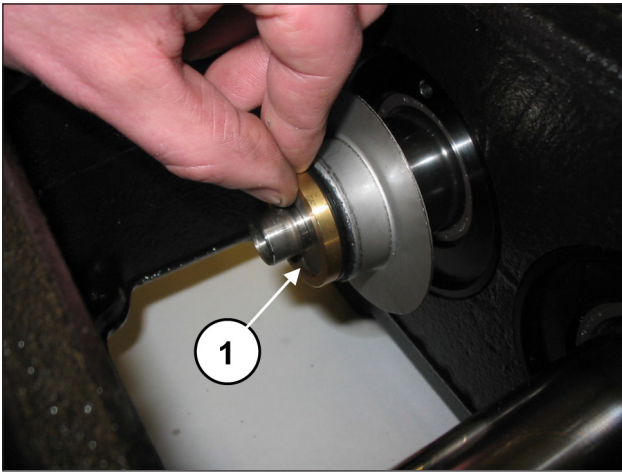

Fig. 98

Insérer le joint torique (rep. ①, Fig. 99) sur les deux couvercles d'inspection et monter les couvercles à l'aide de 4+4 vis M6x14 (rep. ①, Fig. 100).

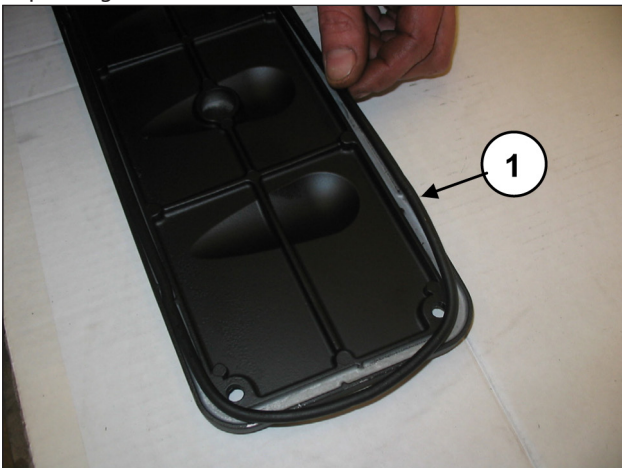

Fig. 99

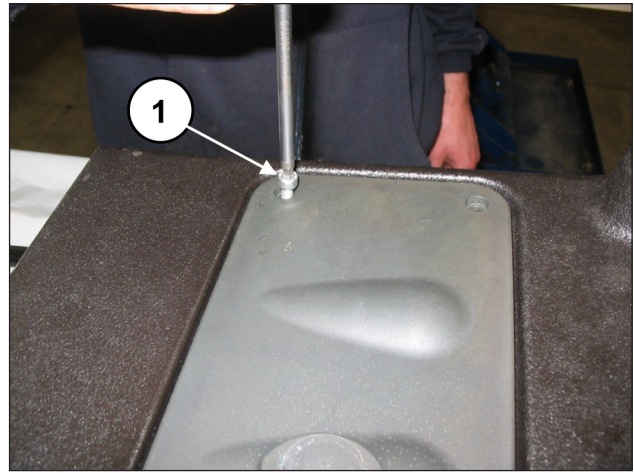

Fig. 100

Serrer les vis à l'aide d'une clé dynamométrique, en suivant les explications du chapitre 3 « Forces de serrage des vis ». Monter le couvercle sur l'extrémité de l'arbre et le fixer au carter à l'aide de 3 vis M8x20 (rep. ①, Fig. 101). Serrer les vis à l'aide d'une clé dynamométrique, en suivant les explications du chapitre 3 « Forces de serrage des vis ».

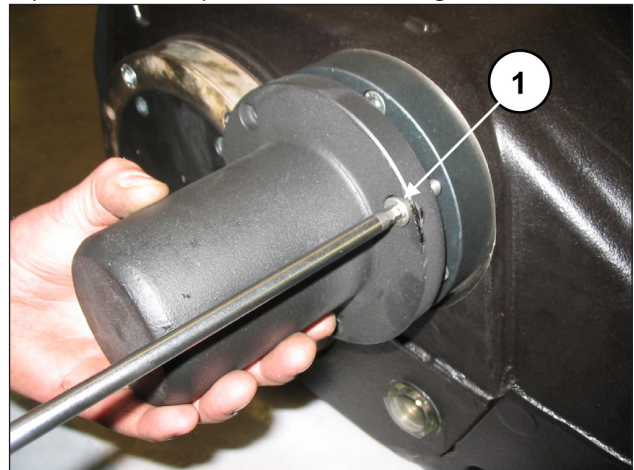

Fig. 101

Poser la languette sur l'arbre PTO (rep. ①, Fig. 102).

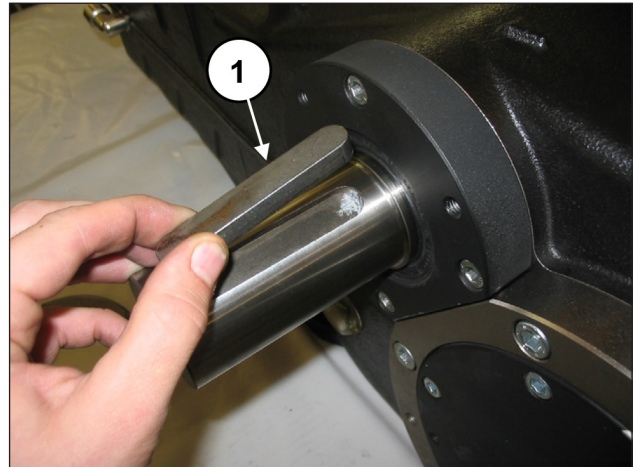

Fig. 102

2.1.3 Classes de majorations prévues

TABLEAU DE MAJORATIONS POUR VILEBREQUIN ET DEMI-COUSSINETS DE BIELLE			
Classes de rattrapage (mm)	Code Demi-coussinet Supérieur	Code Demi-coussinet Inférieur	Rectification sur le diamètre du goujon de l'arbre (mm)
0.25	90931100	90930100	Ø92.75 0/-0.03 Ra 0.4 Rt 3.5
0.50	90931200	90930200	Ø92.50 0/-0.03 Ra 0.4 Rt 3.5

TABLEAU DES MAJORATIONS POUR CARTER DE POMPE ET GUIDE DE PISTON		
Classes de rattrapage (mm)	Référence Guide de piston	Rectification sur le siège du carter de pompe (mm)
1.00	79050543	Ø81 H6 +0.022/0 Ra 0.8 Rt 6

2.2 RÉPARATION DE LA PARTIE HYDRAULIQUE

2.2.1 Désassemblage de la tête - groupes des soupapes

La tête nécessite un entretien préventif, selon les indications du *Manuel d'utilisation et d'entretien*.

Les interventions se limitent à l'inspection ou au remplacement des soupapes, en cas de besoin.

Pour l'extraction des groupes de la soupape, procéder de la façon suivante :

Desserrer le dispositif d'ouverture des soupapes à l'aide d'une clé de 30 mm (rep. ①, Fig. 103).

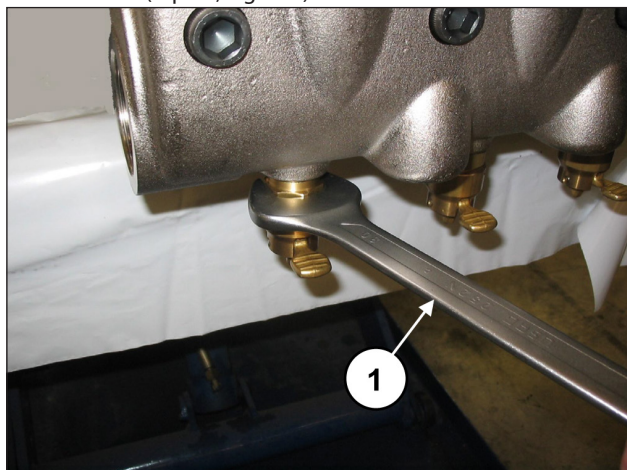

Fig. 103

Appliquer deux soutiens avec filetage G2" sur les raccords de refoulement de la tête (rep. ①, Fig. 104) puis desserrer les 8 vis M16x150 (rep. ①, Fig. 105).

Éviter de heurter les pistons durant l'extraction de la tête.

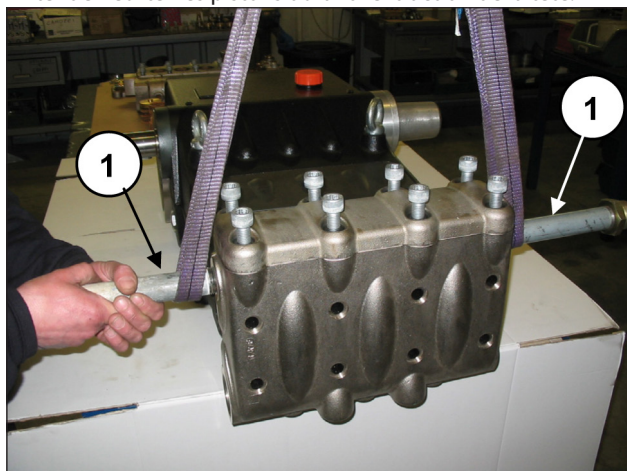

Fig. 104

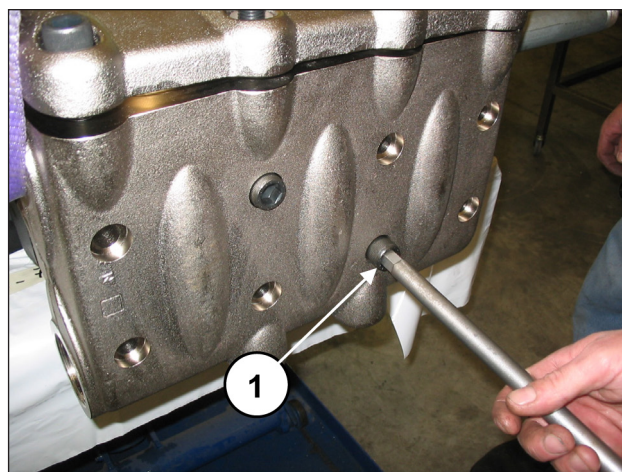

Fig. 105

Déposer les 8 vis M16x150 du couvercle des soupapes (rep. ①, Fig. 106) et déposer le couvercle (rep. ①, Fig. 107).

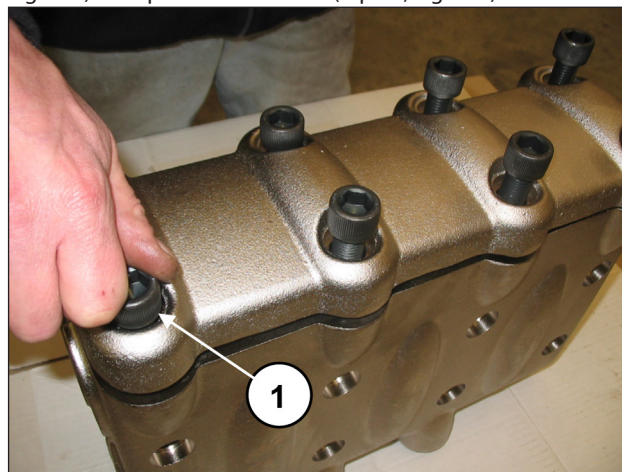

Fig. 106

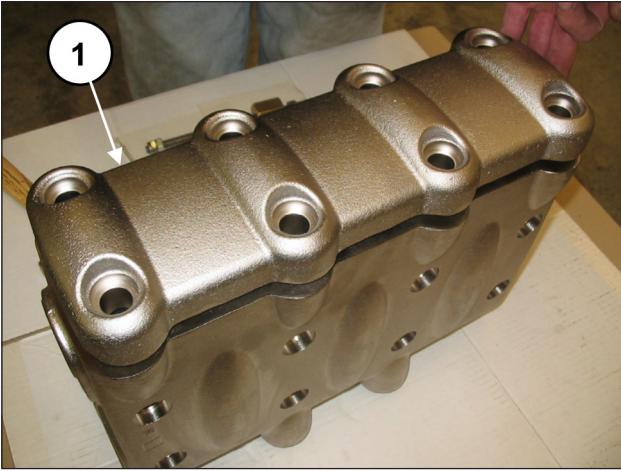

Fig. 107

Extraire le bouchon de soupape en appliquant un chasoir à inertie sur l'orifice M10 du bouchon (rep. ①, Fig. 108).

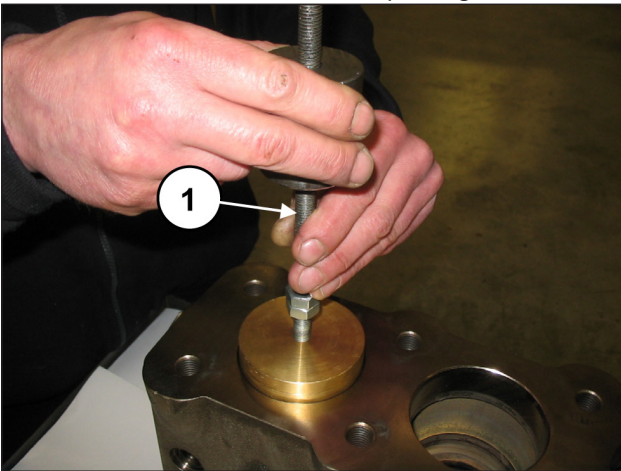

Fig. 108

Dégager le ressort (rep. ①, Fig. 109).

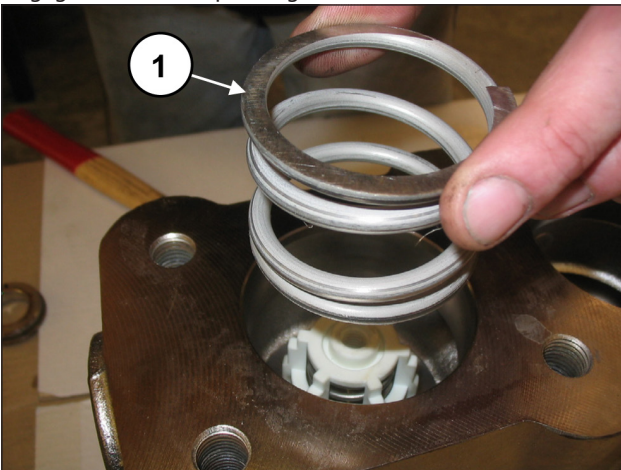

Fig. 109

Extraire le groupe soupape de refoulement en appliquant un chasoir à inertie sur l'orifice M10 du guide de soupape (rep. ①, Fig. 110).

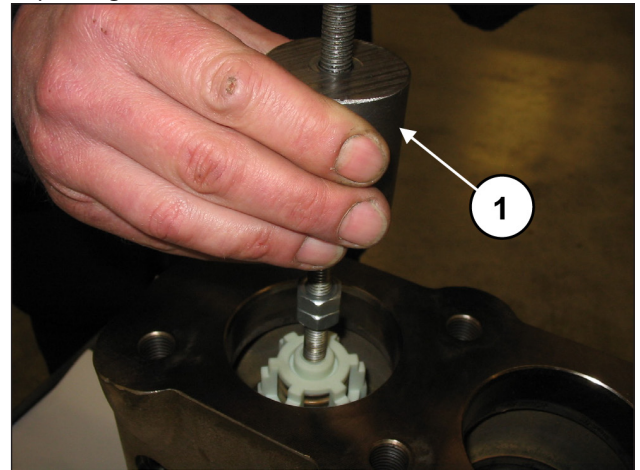

Fig. 110



S'il s'avère difficile d'extraire le groupe de la soupape de refoulement (par exemple, à cause de la présence d'incrustations dues à un arrêt prolongé de la pompe), utiliser l'extracteur réf. 27516400.

Extraire l'entretoise du guide de soupape à l'aide d'une clé hexagonale de 8 mm (rep. ①, Fig. 111).

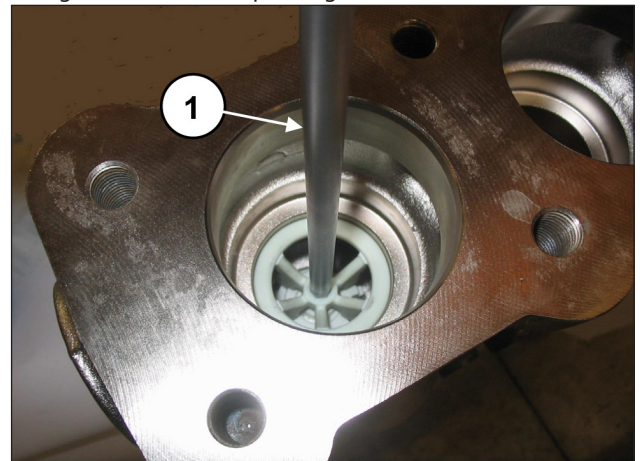

Fig. 111

Extraire le groupe soupape d'aspiration en appliquant un chasoir à inertie sur l'orifice M10 du guide de soupape (rep. ①, Fig. 112).

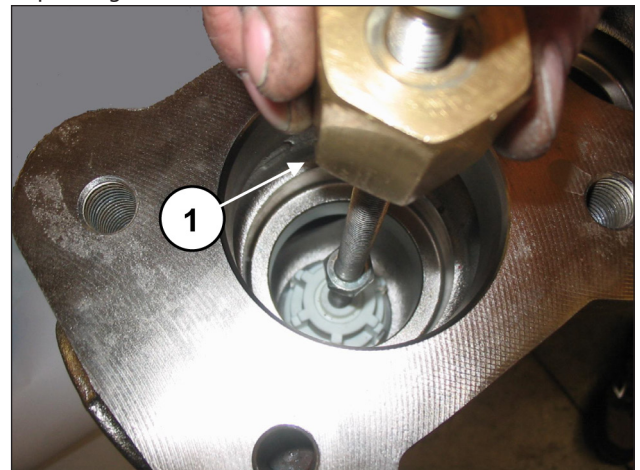

Fig. 112



S'il s'avère difficile d'extraire le groupe de la soupape d'aspiration (par exemple, à cause de la présence d'incrustations dues à un arrêt prolongé de la pompe), utiliser l'extracteur réf. 27516200 (pour LK36-LK40-LK45) ou réf. 27516300 (pour LK50-LK55-LK60) (rep. ①, Fig. 113) et agir selon les indications.

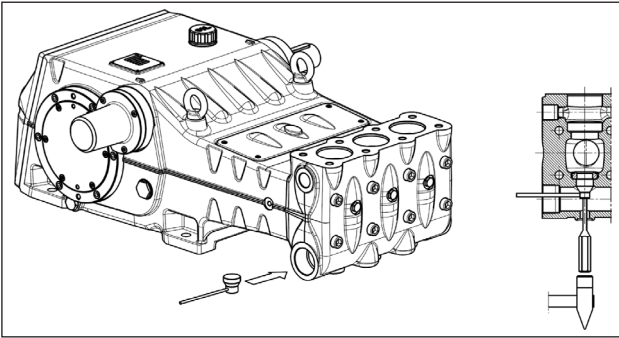

Fig. 113

Démonter les groupes de la soupape d'aspiration et de refoulement en vissant une vis M10 de sorte à appuyer sur le guide interne pour l'extraire du siège de la soupape (rep. ①, Fig. 114).

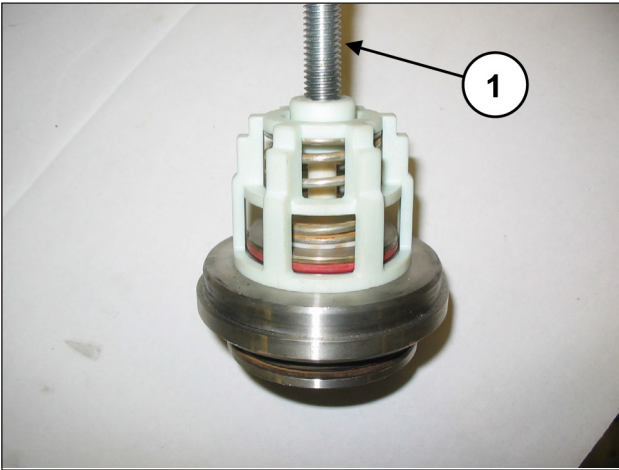

Fig. 114

2.2.2 Remontage de la tête - ensembles de soupapes



Vérifier l'état d'usure des différents composants et les remplacer si nécessaire.

À chaque contrôle des soupapes, remplacer tous les joints toriques aussi bien des groupes que des bouchons de la soupape.



Avant de replacer les groupes de la soupape, nettoyer et essuyer à fond les logements correspondants situés dans la tête et indiqués par les flèches (rep. ①, Fig. 115).

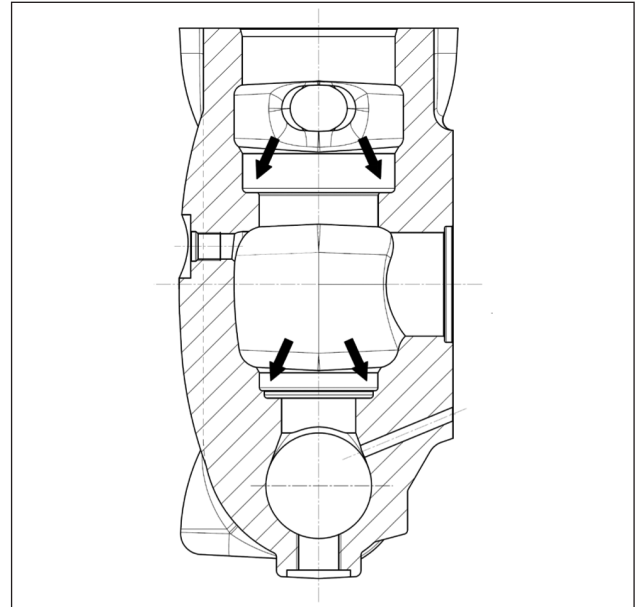

Fig. 115

Procéder au remontage en inversant les opérations de démontage du parag. 2.2.1.

Assembler les groupes de la soupape d'aspiration et de refoulement (Fig. 116 et Fig. 117) en ayant soin de ne pas inverser les ressorts préalablement démontés.

Pour monter plus facilement le guide de soupape dans le siège, il est possible d'utiliser un tuyau posé sur les plans horizontaux du guide (Fig. 118) et un outil à inertie pour agir sur toute la circonférence.



Fig. 116

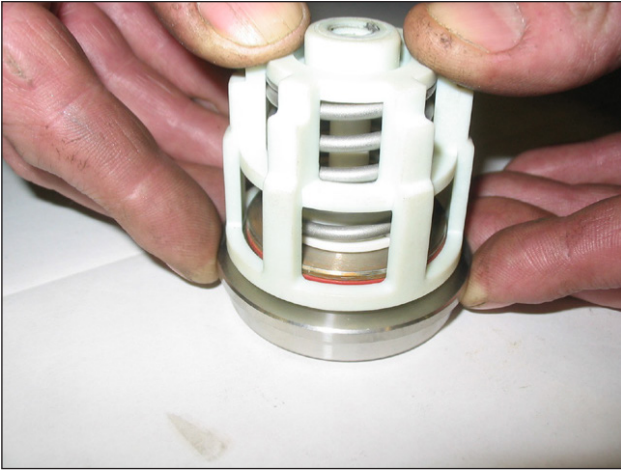

Fig. 117

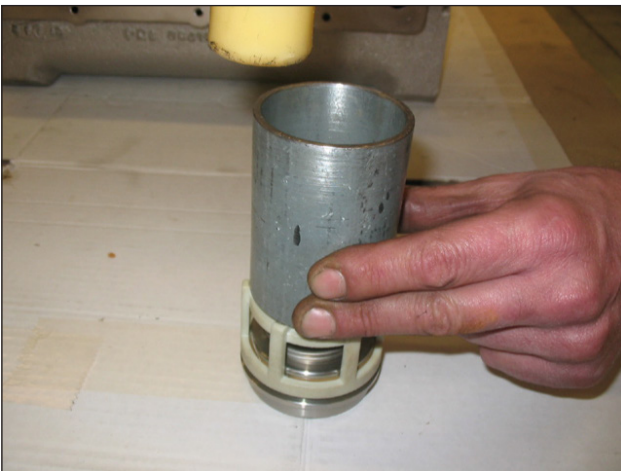

Fig. 118



Insérer les groupes de la soupape (aspiration et refoulement) dans la tête en respectant la séquence de pose des joints toriques et des bagues anti-extrusion.

La séquence correcte de montage des groupes soupape dans la tête est la suivante :

Insérer la bague anti-extrusion, rep. vue éclatée 4 (rep. ①, Fig. 119).

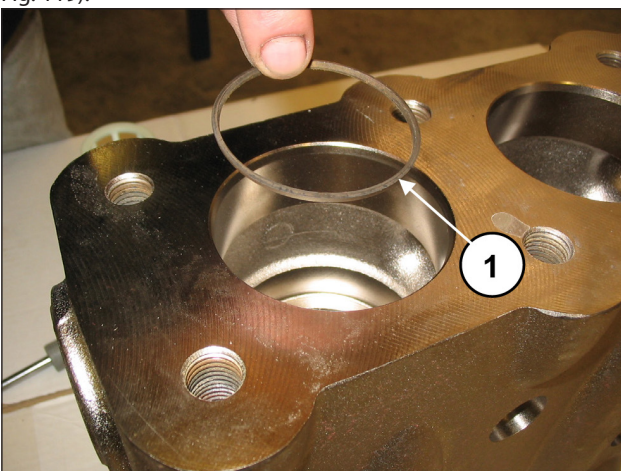

Fig. 119

Insérer le joint torique, rep. vue éclatée 5 (rep. ①, Fig. 120).

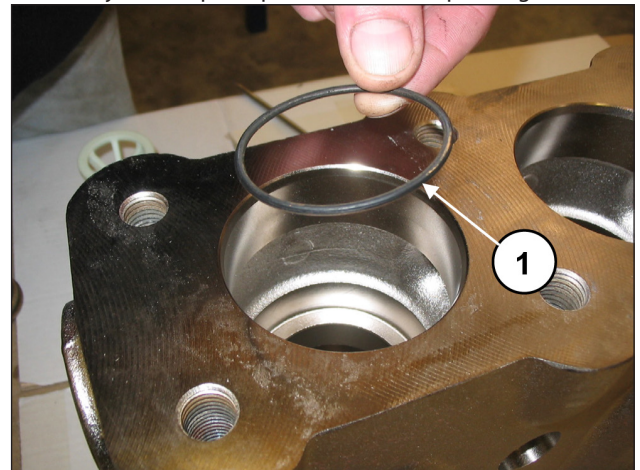

Fig. 120

S'assurer que le joint torique et la bague anti-extrusion sont entrés dans leur logement.

Insérer le groupe soupape d'aspiration (rep. ①, Fig. 121) puis l'entretoise (rep. ①, Fig. 122).

Pousser à fond le groupe soupape qui devra se présenter comme suit, rep. ①, Fig. 122.

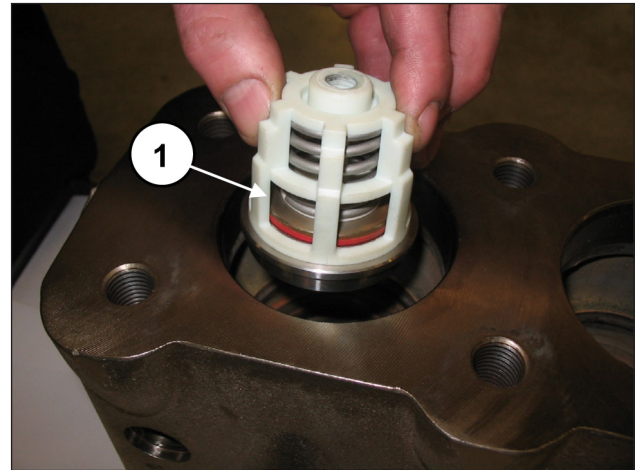

Fig. 121

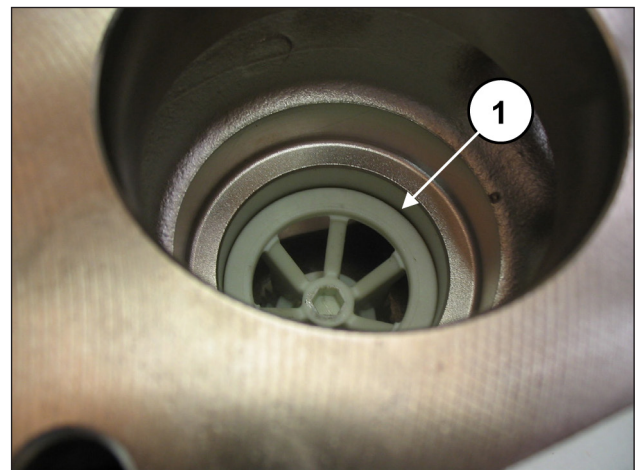

Fig. 122

Monter le joint torique, rep. vue éclatée 5 (rep. ①, Fig. 123) et la bague anti-extrusion, rep. vue éclatée 15 (rep. ②, Fig. 123) sur le siège de la soupape de refoulement.

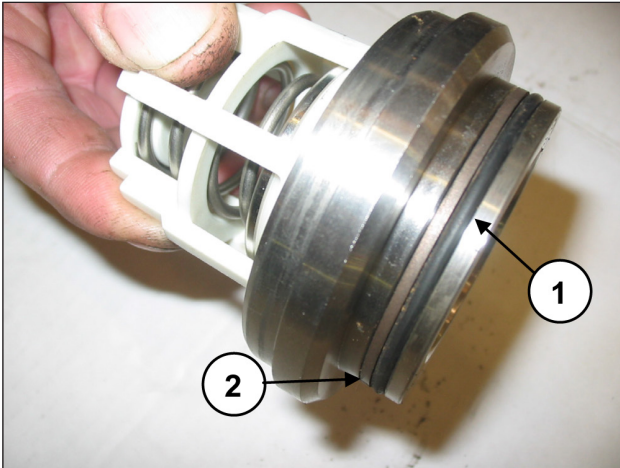

Fig. 123

Insérer le groupe soupape de refoulement (rep. ①, Fig. 124). Pousser à fond le groupe soupape qui devra se présenter comme suit, rep. ①, Fig. 125.

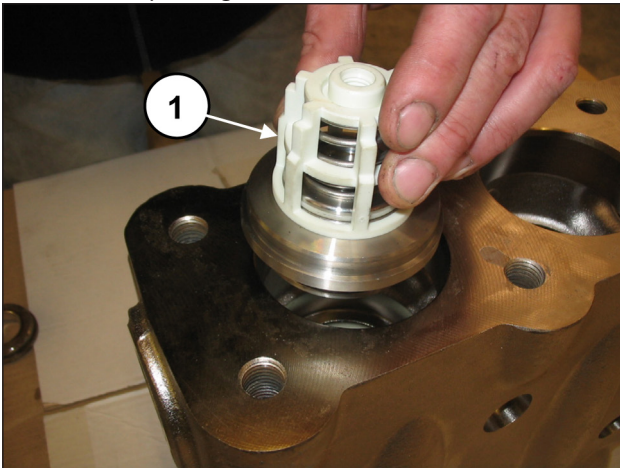

Fig. 124

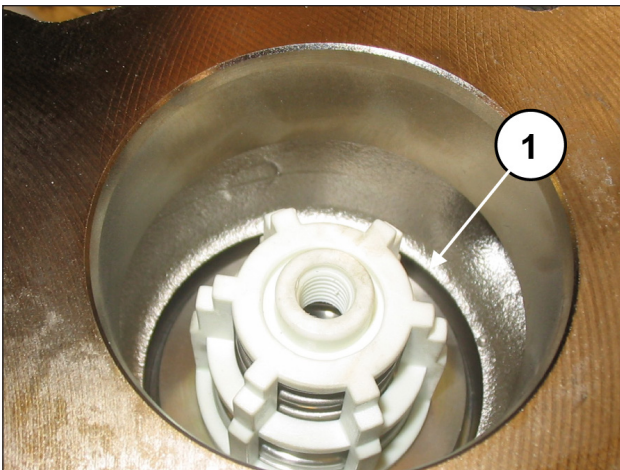

Fig. 125

Insérer la bague anti-extrusion, rep. vue éclatée 16 (rep. ①, Fig. 126).

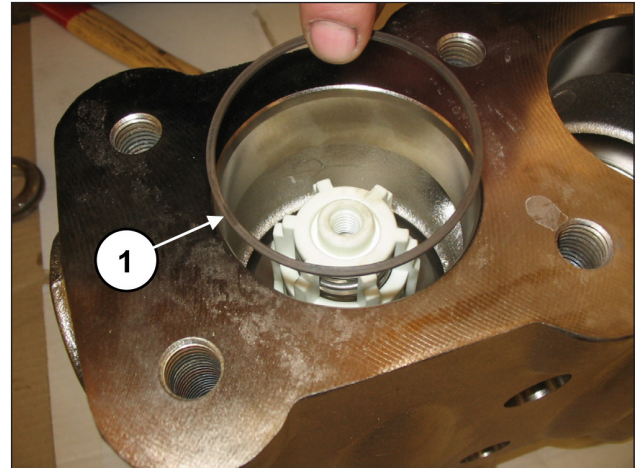

Fig. 126

Insérer le joint torique, rep. vue éclatée 17 (rep. ①, Fig. 127).

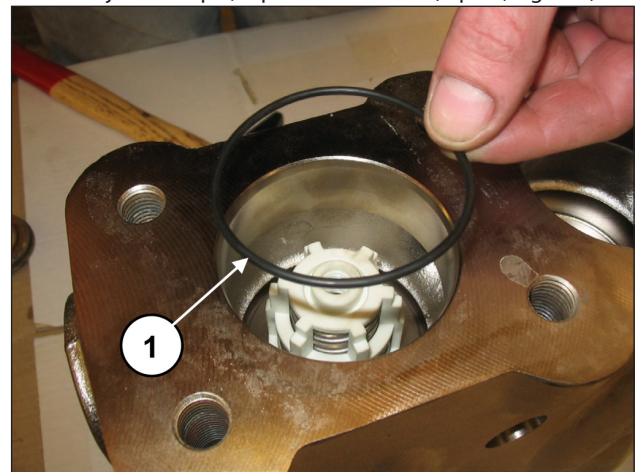

Fig. 127



Installer le joint torique rep. ①, Fig. 128 avec précaution.

Il est conseillé d'utiliser l'outil réf. 27516000 (pour LK36-LK40-LK45) ou réf. 27516100 (pour LK50-LK55-LK60) pour éviter de couper le joint torique en phase d'installation.

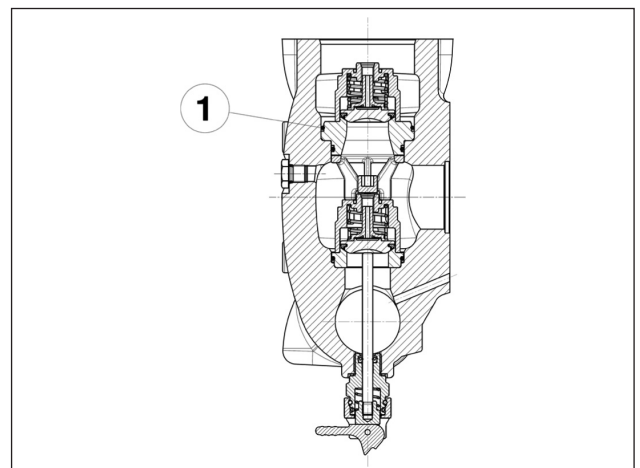

Fig. 128

Insérer la bague du logement de la soupape (rep. ①, Fig. 129) et le ressort (rep. ①, Fig. 130).

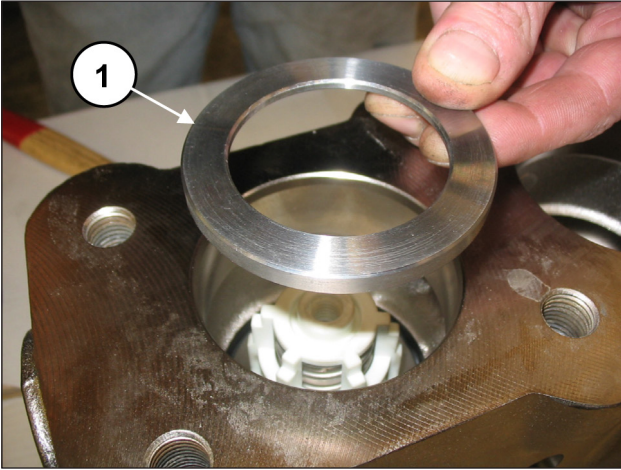

Fig. 129

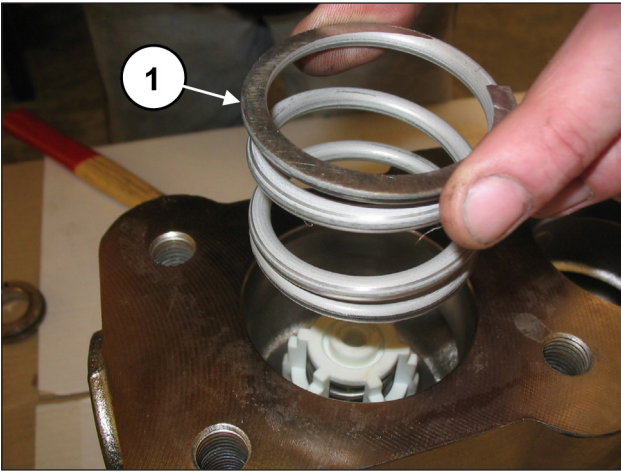

Fig. 130

Monter le joint torique, rep. vue éclatée 17 (rep. ①, Fig. 131) et la bague anti-extrusion, rep. vue éclatée 21 (rep. ②, Fig. 131) sur le bouchon de la soupape de refoulement.

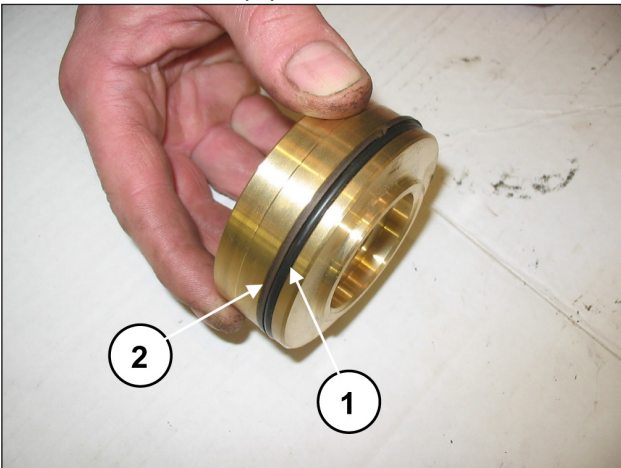

Fig. 131

Insérer le bouchon de la soupape avec le joint torique et la bague anti-extrusion.

Après avoir monté les groupes soupape et le bouchon de la soupape, poser le couvercle des soupapes (rep. ①, Fig. 132) et serrer les 8 vis M16x55 (rep. ①, Fig. 133).

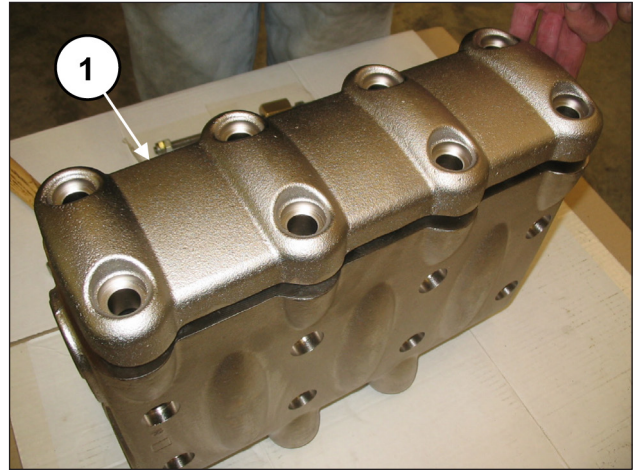

Fig. 132

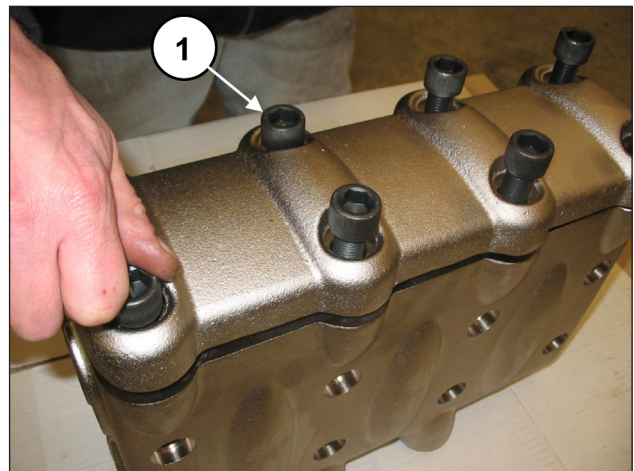

Fig. 133

Monter la tête sur le carter de pompe (rep. ①, Fig. 134) en ayant soin de ne pas heurter les pistons puis visser les 8 vis M16x150 (rep. ①, Fig. 135).

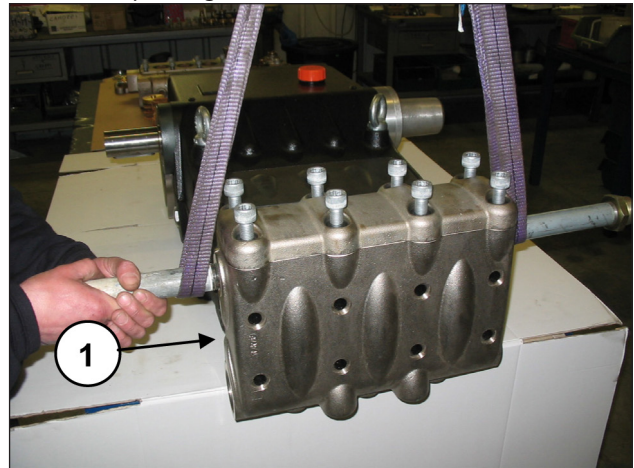

Fig. 134

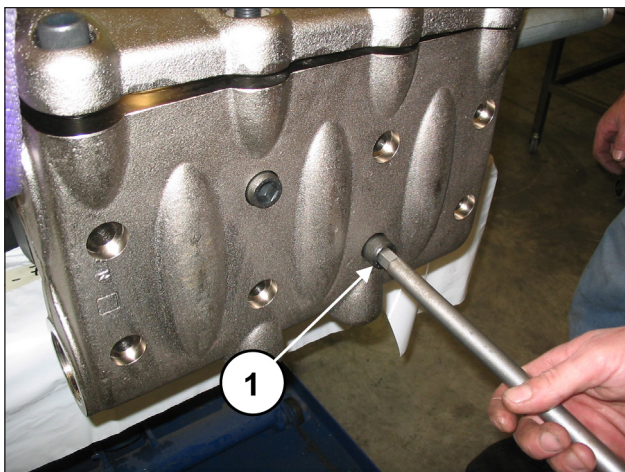

Fig. 135

Serrer les vis M16x150 à l'aide d'une clé dynamométrique, en suivant les explications du chapitre 3 « Forces de serrage des vis ».



Serrer les 8 vis M16x150 en partant des 4 vis internes et en les croisant (voir Fig. 135), puis passer aux 4 vis externes, toujours en croix.

Serrer les vis M16x55 du couvercle à l'aide d'une clé dynamométrique, en suivant les explications du chapitre 3 « Forces de serrage des vis ».

Appliquer les dispositifs d'ouverture des soupapes (rep. ①, Fig. 136) et les serrer à l'aide d'une clé de 30 mm (rep. ①, Fig. 137).

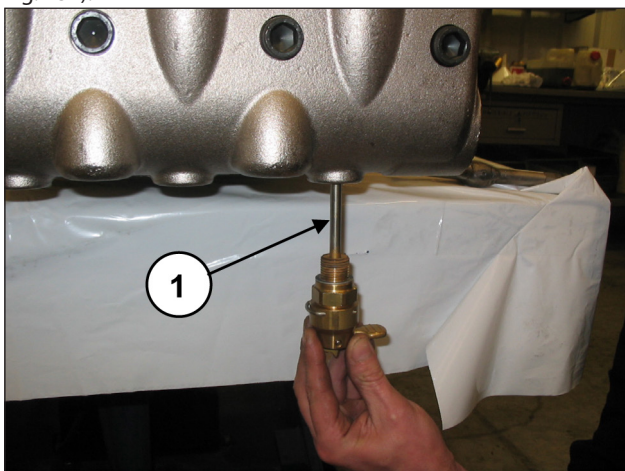

Fig. 136

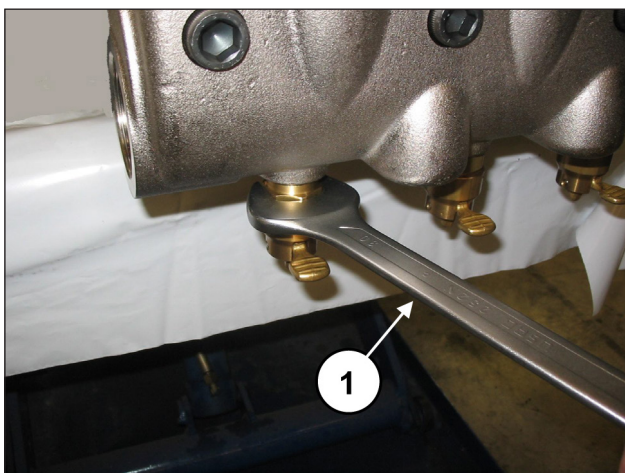

Fig. 137

2.2.3 Démontage du groupe piston - supports - joints d'étanchéité

Le groupe piston nécessite un contrôle périodique comme l'indique le tableau d'entretien préventif du *Manuel d'utilisation et d'entretien*.

Les interventions se limitent à un contrôle visuel du drainage éventuel à travers l'orifice présent sur le couvercle inférieur. En cas d'anomalies / oscillations sur le manomètre de refoulement ou d'égouttement à travers l'orifice de drainage, procéder à un contrôle et remplacer éventuellement le lot de joints.

Pour l'extraction des groupes du piston, procéder de la façon suivante :

Pour accéder au groupe piston, desserrer les vis M16x150 et démonter la tête.



Dégager la tête avec précaution pour éviter de heurter les pistons.

Démonter les pistons en desserrant les vis de fixation (rep. ①, Fig. 138).

Dégager le piston du support des joints et contrôler que la surface du piston ne présente aucune rayure, aucun signe d'usure ou de cavitation.

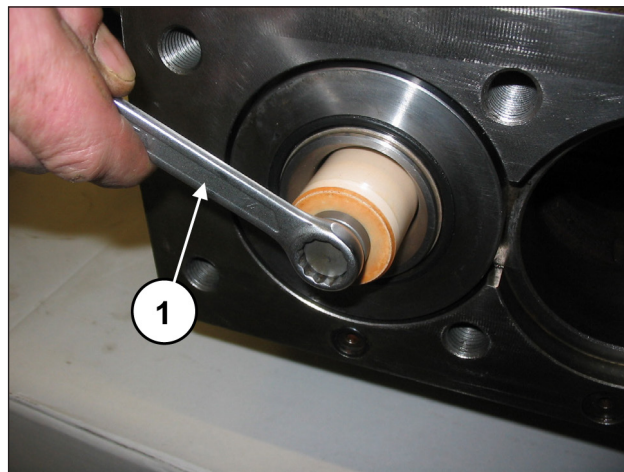

Fig. 138

Déposer le couvercle d'inspection supérieur (rep. ①, Fig. 139) et inférieur (rep. ①, Fig. 140) en dévissant les 4+4 vis de fixation.

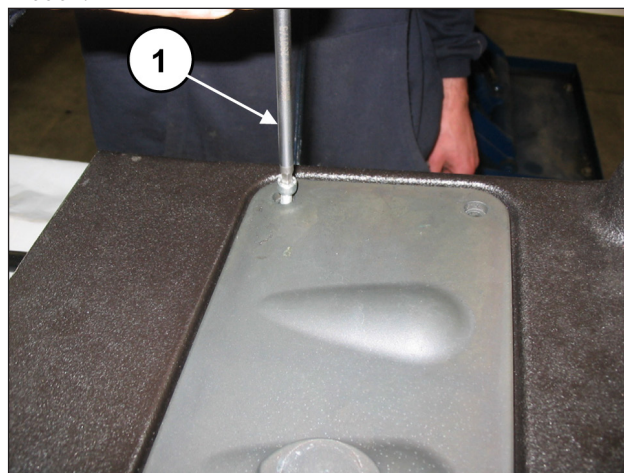

Fig. 139

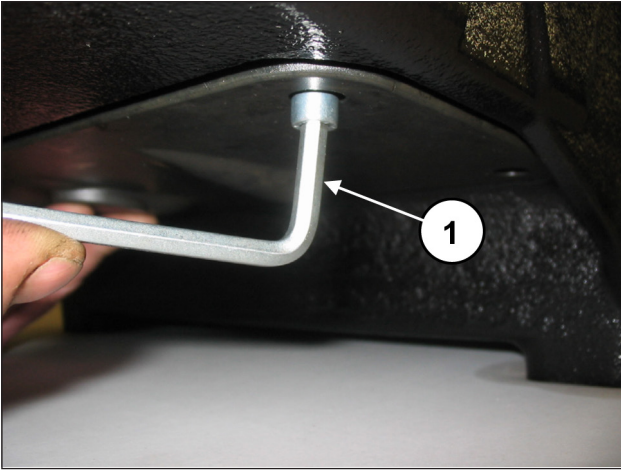

Fig. 140

Tourner manuellement l'arbre de sorte que les 3 pistons se trouvent en position de point mort supérieur. Insérer l'outil tampon réf. 27516600 entre le guide du piston et le piston (rep. ①, Fig. 141).

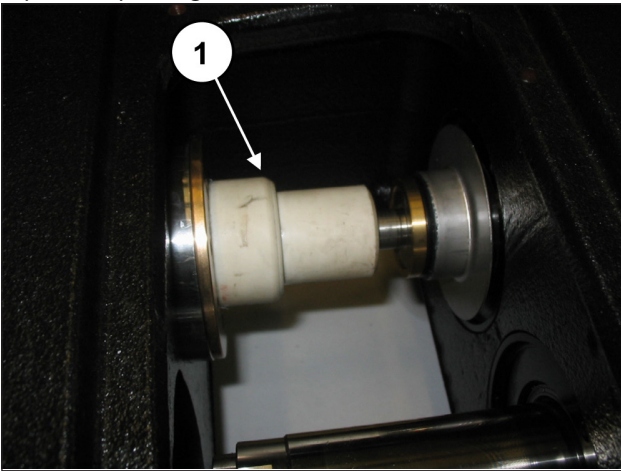

Fig. 141

Tourner l'arbre pour faire avancer le guide du piston de sorte que le tampon, en avançant à son tour, puisse chasser le support des joints et le groupe piston complet (rep. ①, Fig. 142).

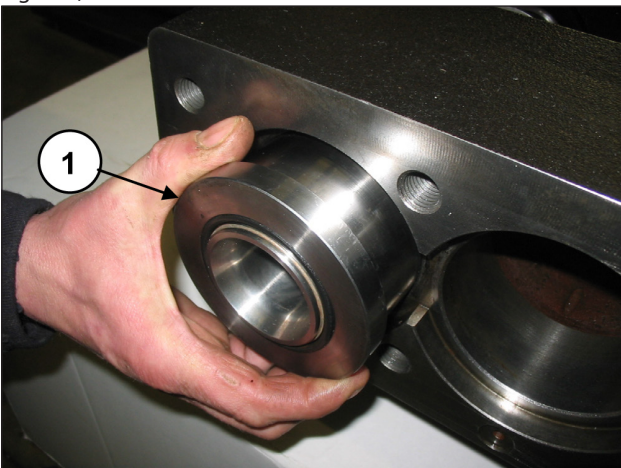

Fig. 142

Dégager le groupe support des joints et l'outil tampon.

Dégager les entretoises anti-éclaboussures des guides de pistons (rep. ①, Fig. 143) puis les joints anti-éclaboussures (rep. ①, Fig. 144).

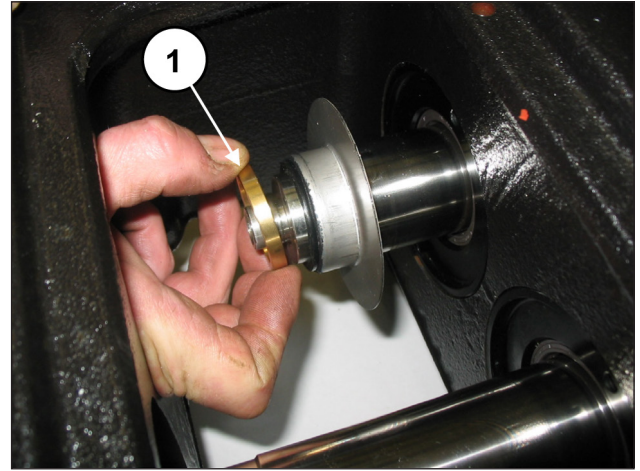

Fig. 143



Fig. 144

Désassembler le support des joints de la chemise à l'aide d'une clé à compas à ergots ronds Ø5, disponible dans le commerce, (rep. ①, Fig. 145) et dévisser le support jusqu'à ce qu'il sorte (rep. ①, Fig. 146).

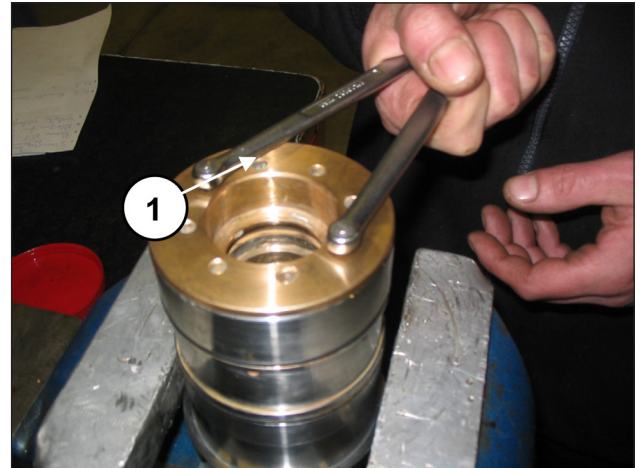

Fig. 145

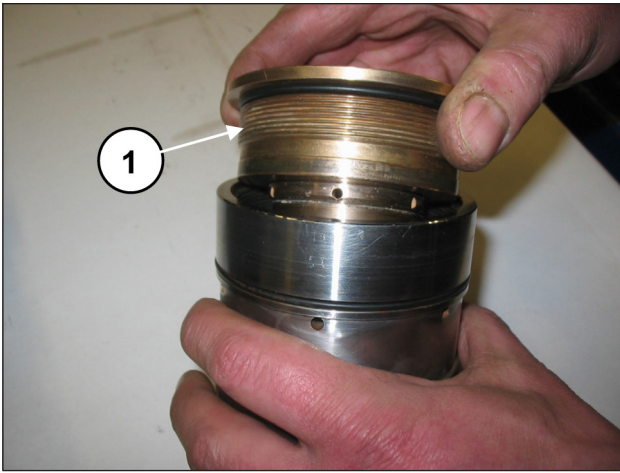

Fig. 146

Extraire manuellement les anneaux de tête, les joints de pression et les anneaux restop (rep. ①, Fig. 147).



Fig. 147

Pour ôter le joint de basse pression, utiliser une jauge d'épaisseur ou un outil qui n'endommage pas le siège du support du joint (rep. ①, Fig. 148).

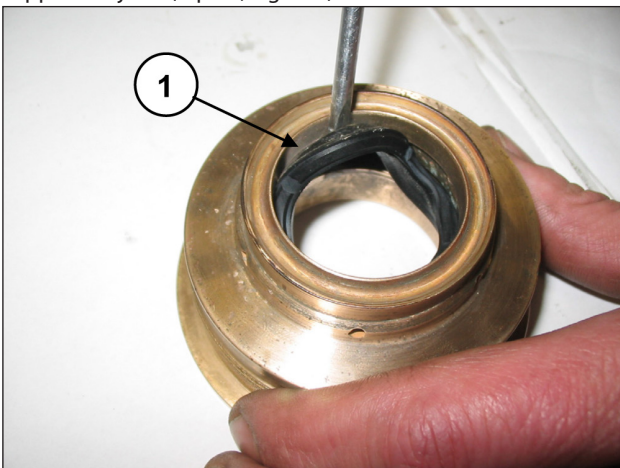

Fig. 148

2.2.4 Montage du groupe piston - supports - joints d'étanchéité

Procéder au remontage en inversant les opérations de démontage du parag. 2.2.3.



Remplacer les joints de pression en humectant les lèvres de graisse à base de silicone (ne pas les enduire) et en ayant soin de ne pas les endommager en les insérant dans la chemise.



Remplacer les joints de pression et les joints toriques à chaque opération de démontage.

Insérer le joint de basse pression dans le support du joint (rep. ①, Fig. 149) en contrôlant le sens de montage qui prévoit que la lèvre d'étanchéité soit tournée en avant (vers la tête).

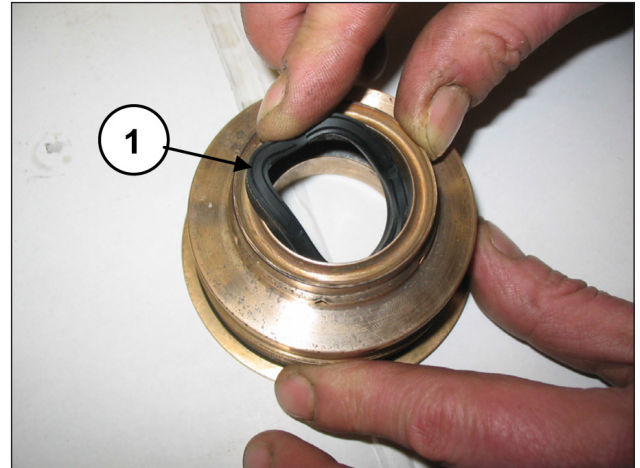

Fig. 149

Monter l'anneau de tête (rep. ①, Fig. 150), le joint de haute pression (rep. ①, Fig. 151) et l'anneau restop (rep. ①, Fig. 152).

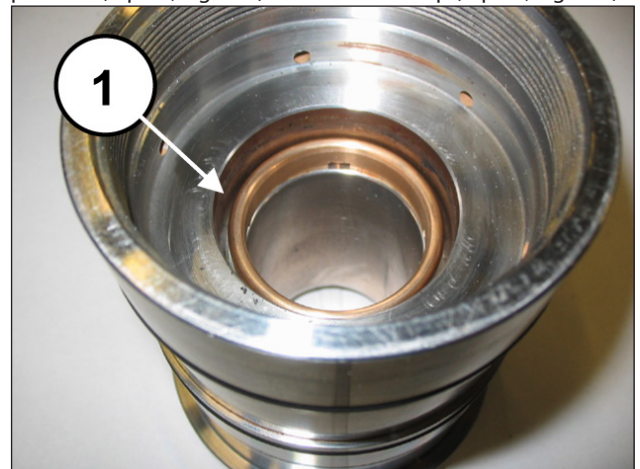

Fig. 150

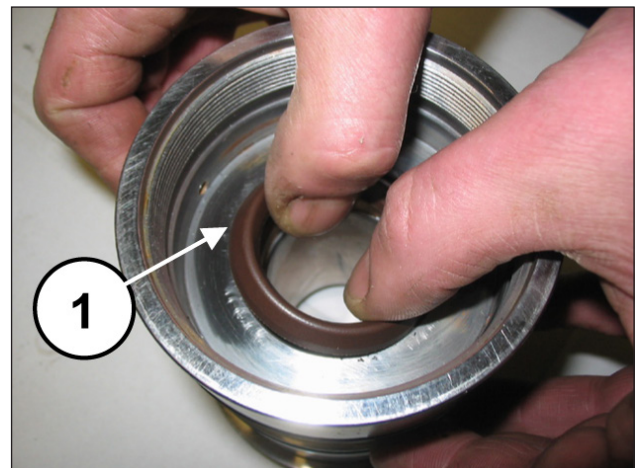

Fig. 151



Fig. 152

Insérer le joint torique du support du joint dans son logement (rep. ①, Fig. 153).

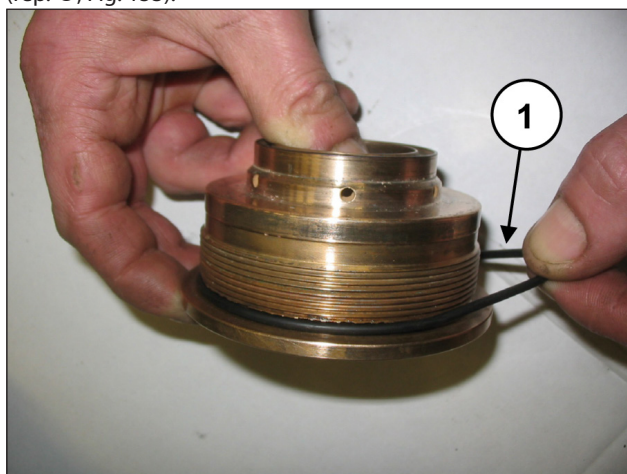

Fig. 153

Visser le support des joints sur la chemise (rep. ①, Fig. 154) et serrer à l'aide d'une clé à compas à ergots ronds Ø5, disponible dans le commerce, (rep. ①, Fig. 155) jusqu'à ce que le support atteigne le fond de la chemise.



Fig. 154

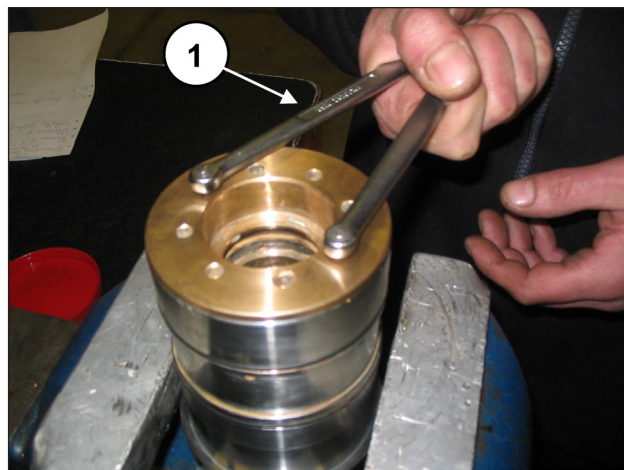

Fig. 155

Insérer la rondelle Ø10x18x0,9 dans la vis de fixation du piston (rep. ①, Fig. 156).

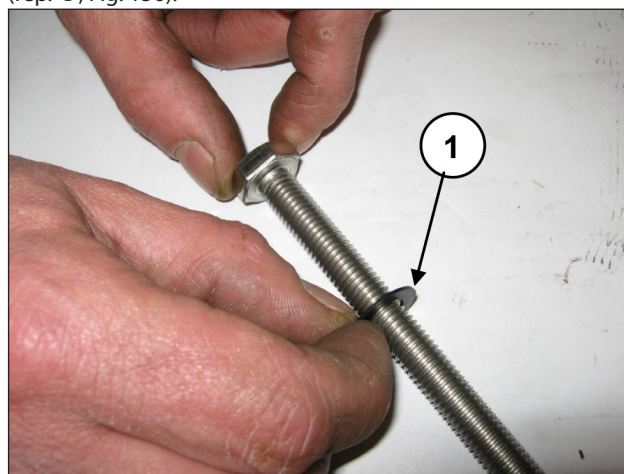

Fig. 156

Monter les pistons sur les guides correspondants (rep. ①, Fig. 157) et les fixer comme le montre le rep. ①, Fig. 158.

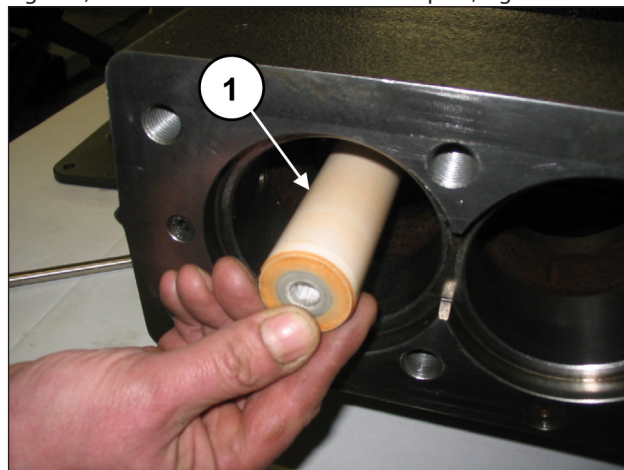

Fig. 157

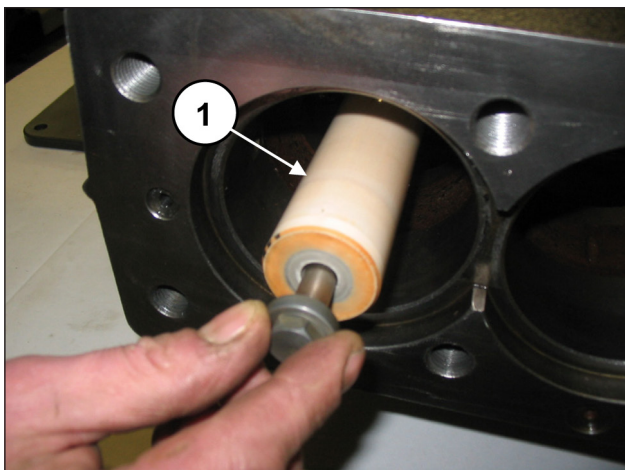

Fig. 158

Serrer les vis à l'aide d'une clé dynamométrique, en suivant les explications du chapitre 3.

Insérer le dispositif de blocage chemise-support de joint (avec leurs joints toriques) préalablement assemblé et le pousser à fond (rep. ①, Fig. 159).



Fig. 159

S'assurer que le dispositif de blocage chemise-support se positionne correctement au fond du logement (rep. ①, Fig. 160).

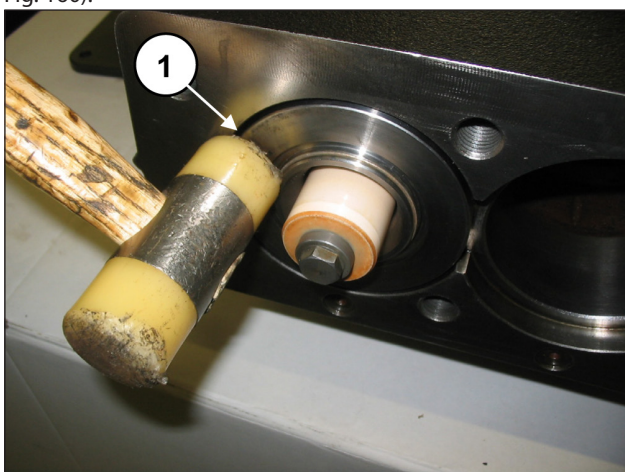

Fig. 160

Monter le joint torique à l'avant de la chemise (rep. ①, Fig. 161) et le joint torique de l'orifice de recirculation (rep. ①, Fig. 162).

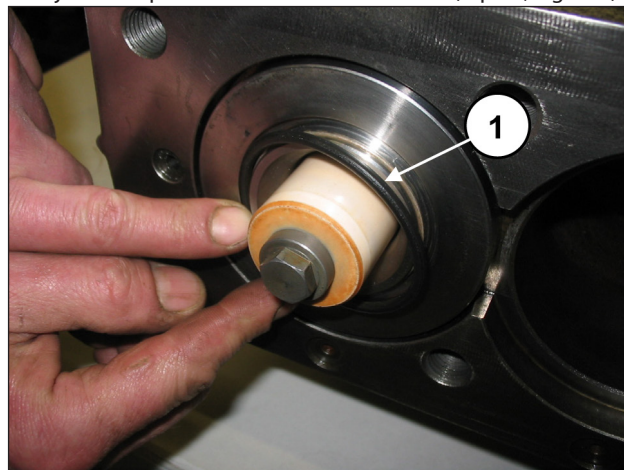

Fig. 161

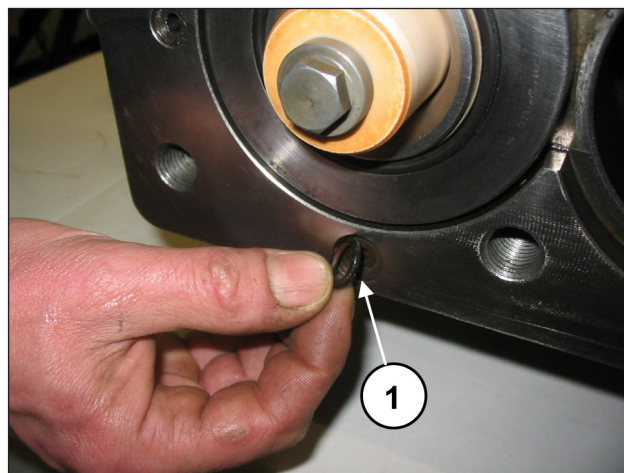

Fig. 162

Insérer le joint torique (rep. ①, Fig. 163) sur les couvercles d'inspection et monter les couvercles à l'aide de 4+4 vis M6x14 (rep. ①, Fig. 164).

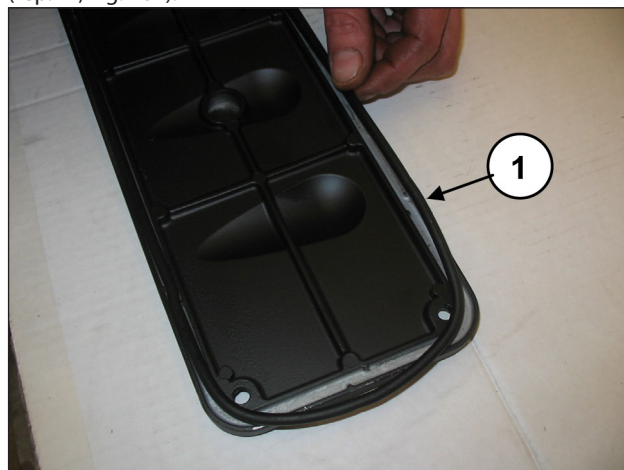

Fig. 163

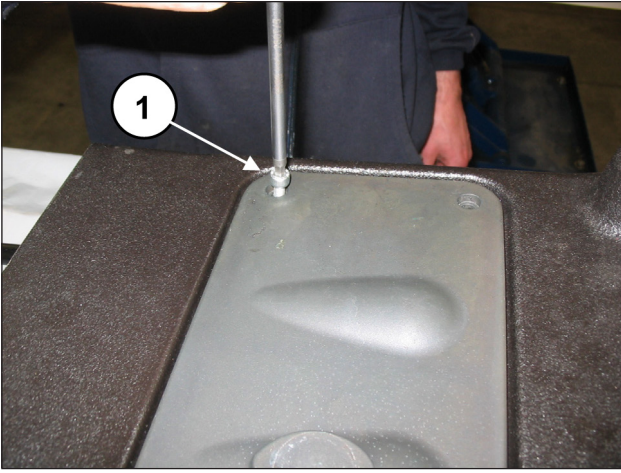

Fig. 164

Serrer les vis à l'aide d'une clé dynamométrique, en suivant les explications du chapitre 3.

2.2.5 Récupération des têtes

Si les chambres des pistons de la tête présentent des signes de cavitation dus à une alimentation incorrecte de la pompe, il est possible de récupérer la tête endommagée pour éviter de la remplacer.

Pour récupérer la tête, procéder aux usinages indiqués Fig. 165 pour LK36-40-45 et Fig. 166 pour LK50-55-60 :

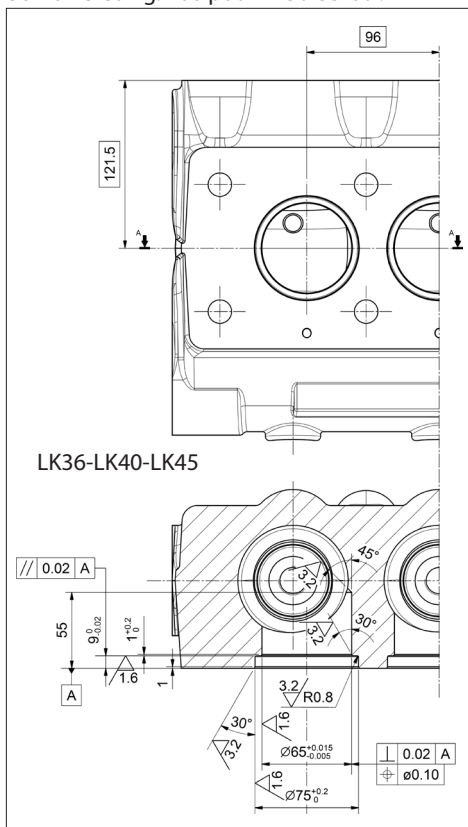

Fig. 165

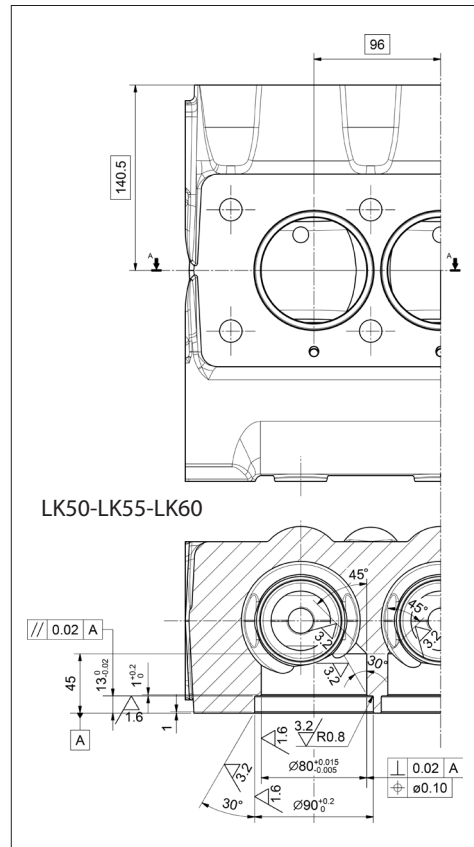

Fig. 166

Après l'avoir usinée, assembler la tête en calant les douilles (rep. ①) dotées de bagues anti-extrusion (rep. ②) et de joint torique (rep. ③) comme le montre la Fig. 167 pour LK36-40-45 et la Fig. 168 pour LK50-55-60 :

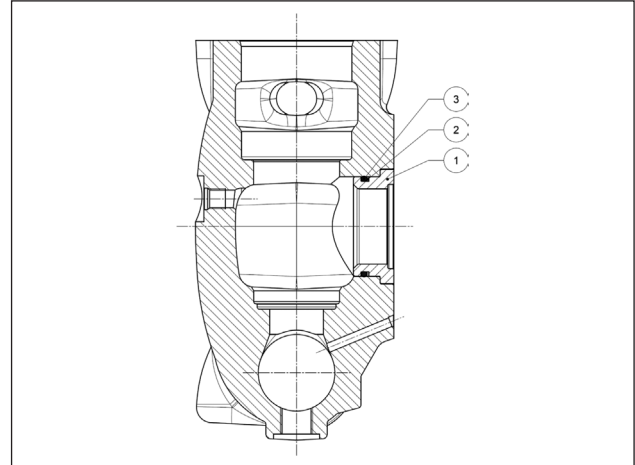

Fig. 167

- 1 - Bague LK36-40-45 - réf. 78216756 - qté 3
- 2 - Bague anti-extrusion - réf. 90526880 - qté 6
- 3 - Joint torique - réf. 90410200 - qté 6

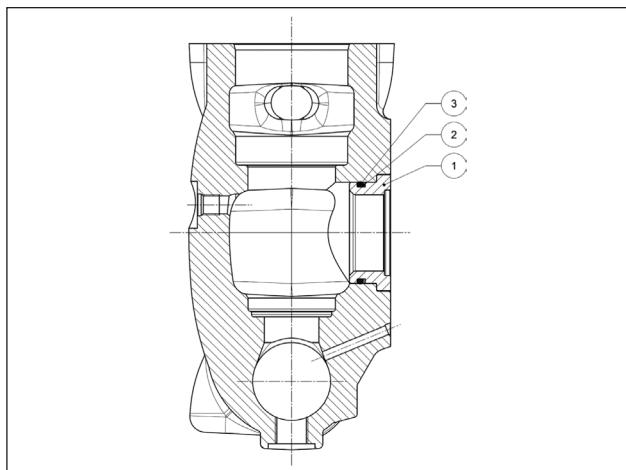

Fig. 168

- 1 - Bague LK50-55-60 - réf. 78216656 - qté 3
 2 - Bague anti-extrusion - réf. 90528500 - qté 6
 3 - Joint torique - réf. 90412900 - qté 6

3 FORCES DE SERRAGE DES VIS

Pour serrer les vis, utiliser exclusivement une clé dynamométrique.

Description	Repère vue éclatée	Couple de serrage Nm
Vis M8x20 couvercle carter	54	25
Bouchon G1/2x13 carter	78	40
Vis M8x30 couv. coussinet PTO	95	25
Vis M8x20 couv. extrémité arbre	54	25
Vis M10x30 couv. support coussinet	69	45
Vis M6x14 couvercles sup. et inf.	82	10
Vis M8x20 couvercle coussinet	54	25
Vis M12x1,25x87 serrage bielle	52	75*
Vis M6x20 guide piston	49	10
Vis M12x25 flasque ret. douille	63	68.5
Vis M10x160 fixation piston	27	40
Vis M16x55 couvercle soupapes	26	333
Bouchon G1/4"x13 tête	13	40
Vis M16x150 tête	25	333**
Dispositif ouverture soupapes	2	40

* Obtenir le couple de serrage en serrant les vis simultanément.

** Serrer les vis en partant des 4 vis internes et en les croisant (voir Fig. 135), puis passer aux 4 vis externes, toujours en croix.

4 OUTILS POUR LA RÉPARATION

Pour l'entretien de la pompe, il est possible d'utiliser des outils traditionnels pour le démontage et le remontage des composants. Les outils suivants sont disponibles :

Pour le montage :

Bague d'étanchéité radiale guide piston	réf. 27910900
Bague d'étanchéité radiale arbre PTO	réf. 27539500
	réf. 27548200
Joint torique siège de soupape de refoulement LK36-LK40-LK45	réf. 27516000
Joint torique siège de soupape de refoulement LK50-LK55-LK60	réf. 27516100

Pour le démontage :

Siège soupape d'aspiration LK36-LK40-LK45	réf. 27516200
Siège soupape d'aspiration LK50-LK55-LK60	réf. 27516300
Siège soupape refoulement	réf. 27516400
Bloc chemise + support joints	réf. 27516600
Arbre (blocage des bielles)	réf. 27566200

5 VERSIONS SPÉCIALES

Suivent les indications concernant la réparation des versions spéciales. Sauf indications contraires, respecter les instructions concernant la pompe LK version standard.

- Pompes LKN : pour la réparation, suivre les indications valables pour la pompe LK standard.

6 REMPLACEMENT DE LA DOUILLE PIED DE LA BIELLE

Procéder au calage de la douille à froid et aux usinages suivants en respectant les dimensions et les tolérances de la Fig. 169 ci-dessous.

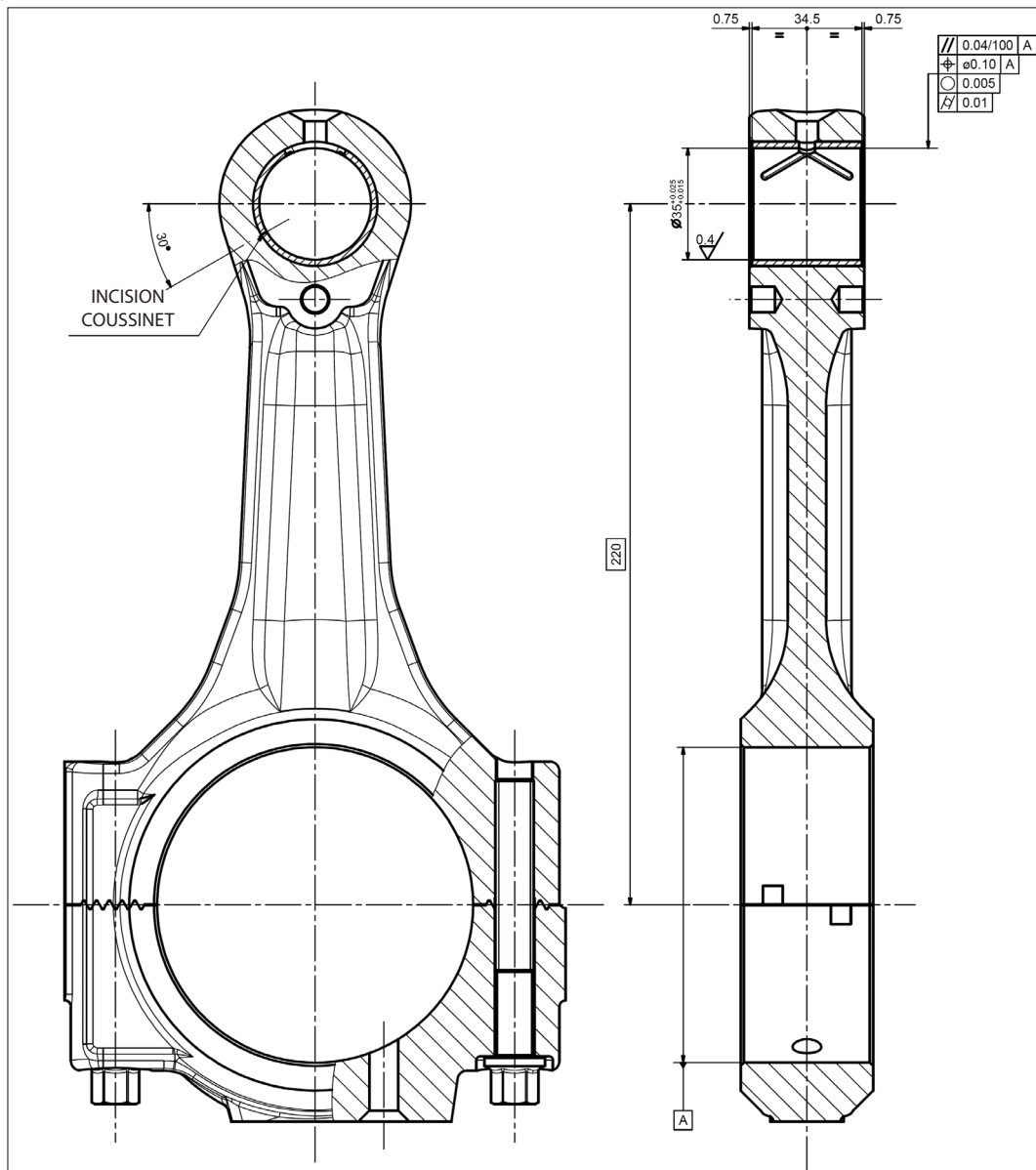

Fig. 169

Inhaltsverzeichnis

1	EINLEITUNG	104
1.1	BESCHREIBUNG DER SYMBOLE.....	104
2	REPARATURVORSCHRIFTEN	104
2.1	REPARATUR DER MECHANIK	104
2.1.1	<i>Ausbau der Mechanik</i>	104
2.1.2	<i>Einbau der Mechanik</i>	112
2.1.3	<i>Vorgesehene Übermaßklassen</i>	122
2.2	REPARATUR DER HYDRAULIK.....	122
2.2.1	<i>Ausbau des Kopfs - Ventilgruppen</i>	122
2.2.2	<i>Einbau des Kopfs - Ventilgruppen</i>	124
2.2.3	<i>Ausbau der Kolbengruppe - Lager - Dichtungen</i>	128
2.2.4	<i>Einbau der Kolbengruppe - Lager - Dichtungen</i>	130
2.2.5	<i>Wiederherstellung des Kopfs</i>	133
3	EICHWERTE FÜR DEN SCHRAUBENANZUG	134
4	REPARATURWERKZEUGE	135
5	SPEZIALVERSIONEN	135
6	AUSTAUSCH DER PLEUELAUGENBUCHSE	136

1 EINLEITUNG

Diese Anleitung enthält die Anweisungen für die Reparatur der Pumpen der Baureihe LK und muss vor jeglichen Arbeiten an der Pumpe sorgfältig gelesen und verstanden werden. Der einwandfreie Betrieb und die lange Lebensdauer der Pumpe sind von der korrekten Verwendung und den angemessenen Wartungseingriffen abhängig. Interpump Group haftet nicht für Schäden durch Nachlässigkeit oder Nichtbeachtung der in dieser Anleitung beschriebenen Vorschriften.

1.1 BESCHREIBUNG DER SYMBOLE

Lesen Sie vor jeder Arbeit stets aufmerksam die Anweisungen in dieser Anleitung.



Warnzeichen



Lesen Sie vor jeder Arbeit stets aufmerksam die Anweisungen in dieser Anleitung.



Gefahrenzeichen
Schutzbrille tragen.



Gefahrenzeichen
Vor jeder Arbeit Schutzhandschuhe anziehen.

2 REPARATURVORSCHRIFTEN



2.1 REPARATUR DER MECHANIK

Vor den Reparaturarbeiten an der Mechanik muss zunächst das Öl aus dem Kurbelgehäuse abgelassen werden. Zum Ablassen des Öls den Öleinfüllverschluss Pos. ①, Abb. 1 und anschließend den Ölablassverschluss abnehmen, Pos. ②, Abb. 1.



Abb. 1



Altöl muss in einem geeigneten Behälter gesammelt und den entsprechenden Wertstoffstellen zugeführt werden. Es darf auf keinen Fall in die Umwelt abgeleitet werden.

2.1.1 Ausbau der Mechanik

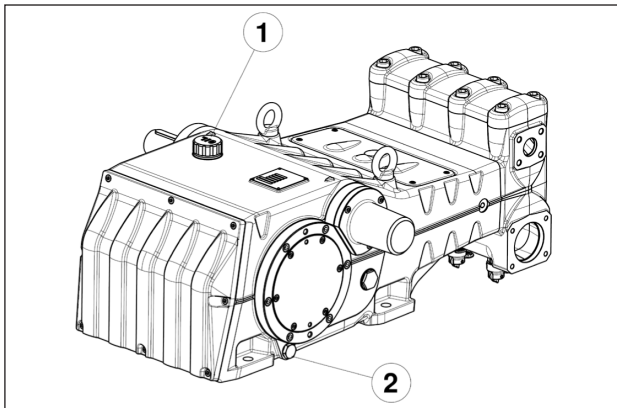
Die vorgeschriebene Arbeitsabfolge lautet:
Lassen Sie die Ölfüllung der Pumpe vollständig ab, vgl. Abschn. 2.1.
Trennen Sie die Ventilöffner des Kopfs und den Kopf vom Pumpengehäuse gemäß den Hinweisen in Abschn. 2.2.1 (von Abb. 103 bis Abb. 105).
Demontieren Sie den oberen und unteren Inspektionsdeckel durch Abdrehen der 4+4 Befestigungsschrauben gemäß Abschn. 2.2.3 (Abb. 139 und Abb. 140).

Ziehen Sie die O-Ringe ab und ersetzen Sie diese bei Bedarf. Entfernen Sie die drei Kolben und die Baugruppen Buchsen-Dichtungshalter lt. Abschn. 2.2.3 (Abb. 138, Abb. 141 und Abb. 142).

Entfernen Sie die drei Spritzschutz-Distanzringe und die Spritzschutzringe lt. Abschn. 2.2.3 (Abb. 143 und Abb. 144). Lösen Sie die Stiftschrauben M6 der drei Ölabstreifring-Deckel (Pos. ①, Abb. 2).



Abb. 2

Drehen Sie einer Gewindestange oder eine Schraube M6 als Abzieher in die entsprechenden Bohrungen am Ölabstreifring-Deckel ein (Pos. ①, Abb. 3) und nehmen Sie die Deckel von der Pumpengruppe ab (Pos. ①, Abb. 4).



Abb. 3

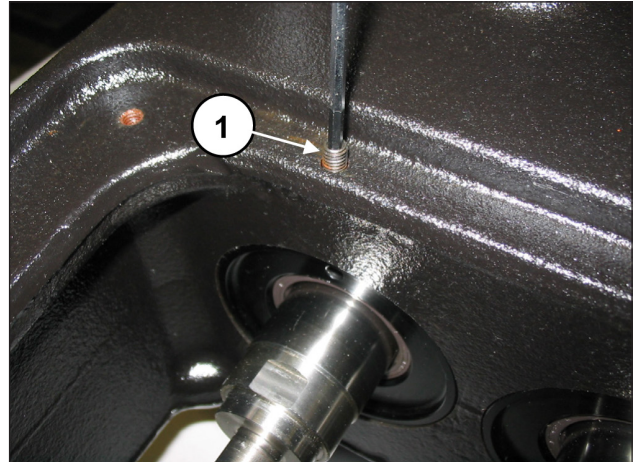

Abb. 4

Entfernen Sie den radialen Dichtring (Pos. ①, Abb. 5) und den äußeren O-Ring (Pos. ①, Abb. 6).

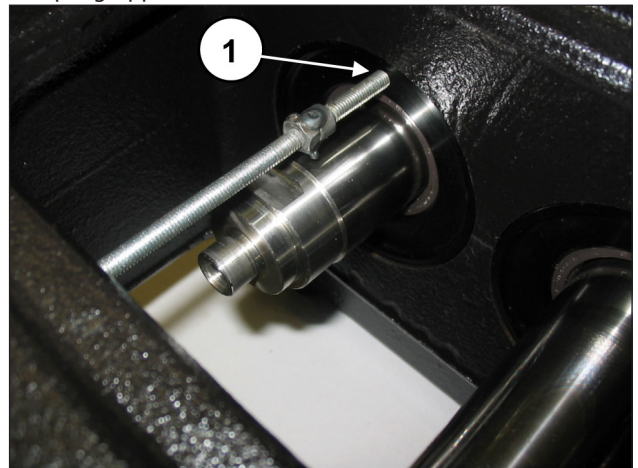

Abb. 5

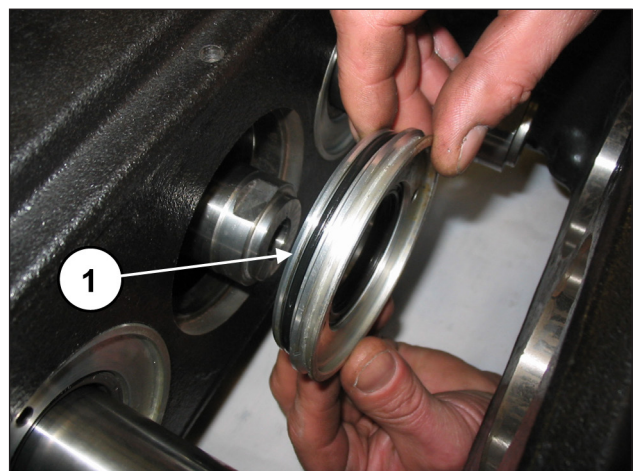

Abb. 6

Nehmen Sie die Passfeder von der Zapfwelle ab (Pos. ①, Abb. 7).

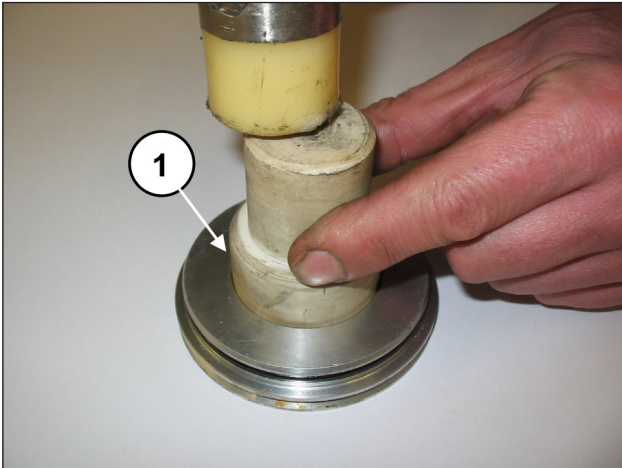

Abb. 7

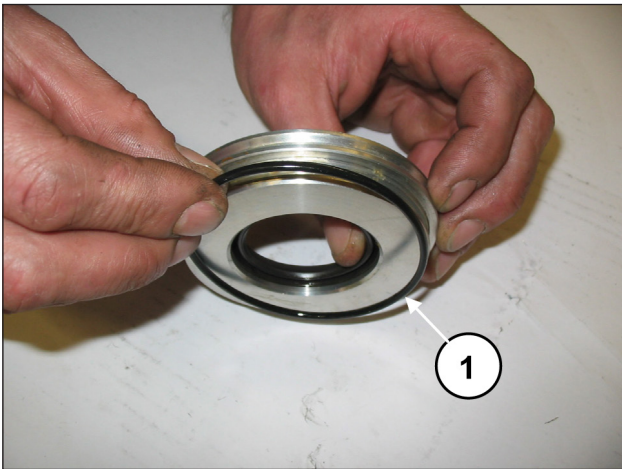
Lösen Sie die Befestigungsschrauben des Wellenendendeckels (Pos. ①, Abb. 8) und ziehen Sie den Deckel von der Zapfwelle ab.

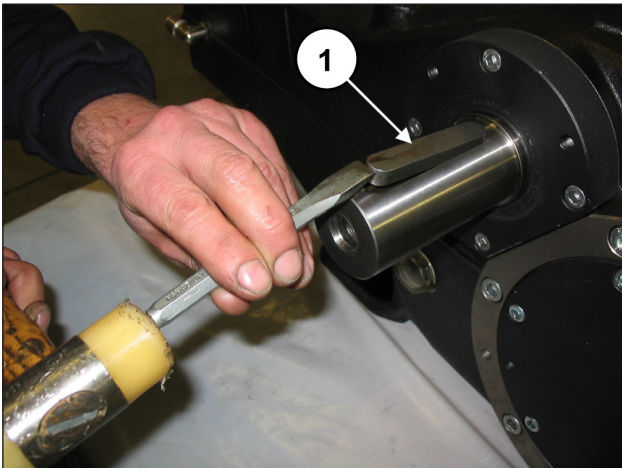

Abb. 8

Lösen Sie die Befestigungsschrauben des Gehäusedeckels (Pos. ①, Abb. 9) und entfernen Sie den Deckel. Ziehen Sie den O-Ring ab und ersetzen Sie diesen bei Bedarf.

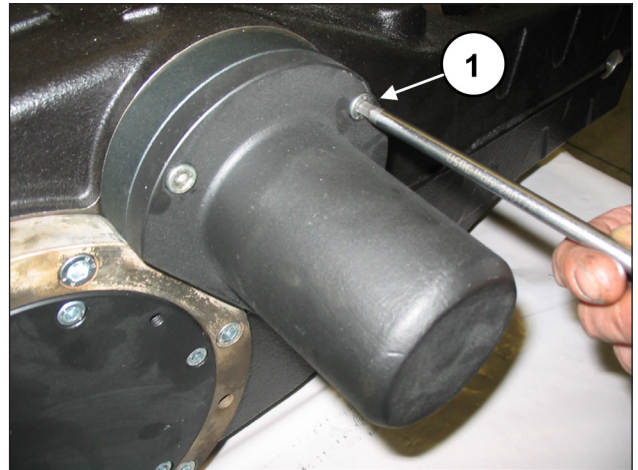

Abb. 9

Demontieren Sie die beiden Lagerdeckel und lösen hierzu die entsprechenden Schrauben (Pos. ①, Abb. 10).

Zum leichteren Ausbau verwenden Sie 2 Stiftschrauben oder Schrauben M8 (Pos. ①, Abb. 11) als Abzieher.

Ziehen Sie den O-Ring ab und ersetzen Sie diesen bei Bedarf.

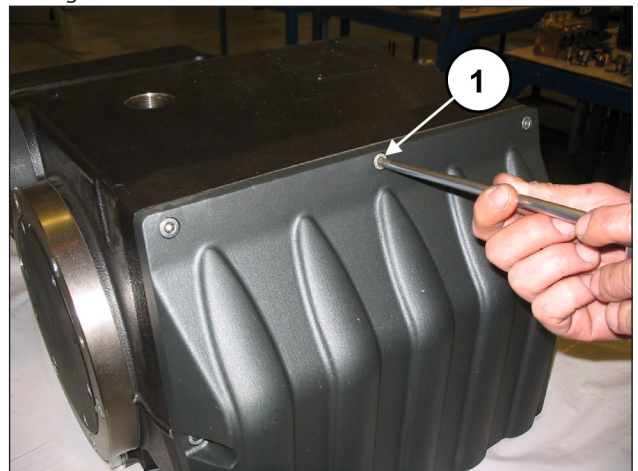

Abb. 10



Abb. 11

Setzen Sie eine Passscheibe unter den Schaft der mittleren Pleuelstange, um die Drehung der Kurbelwelle zu kontern (Pos. ①, Abb. 12).

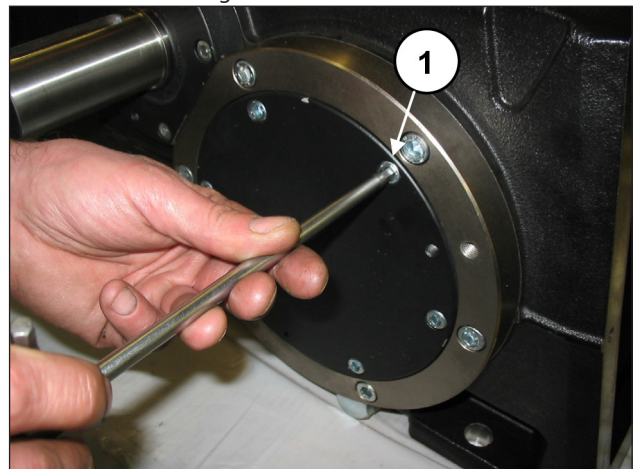

Abb. 12

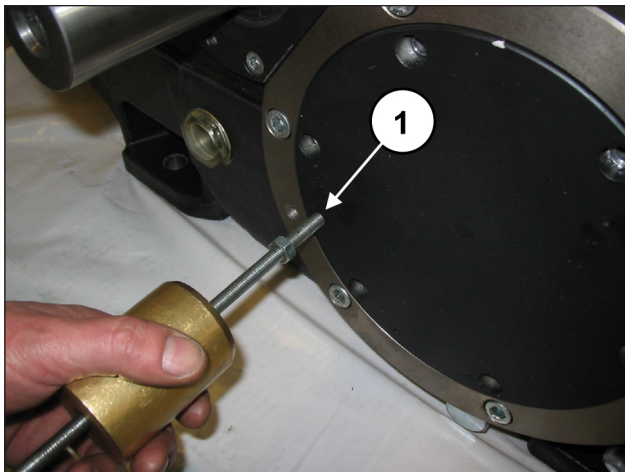
Lösen Sie die Befestigungsschrauben des Buchsenflanschs auf beiden Seiten (Pos. ①, Abb. 13).
Belassen Sie die Buchsenflansche in ihrem Sitz (Pos. ①, Abb. 14).



Abb. 13

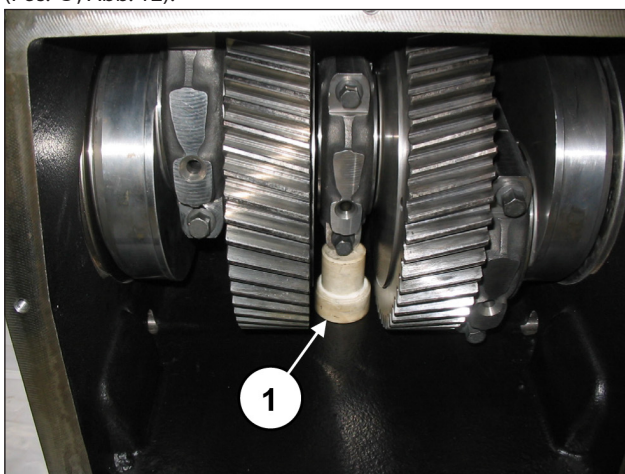

Abb. 14

Drehen Sie auf einer Seite eine Nutmutter Typ SKF KM20 auf die Druckbuchse (Pos. ①, Abb. 15), lösen Sie die Buchse dann mit einem Schlagwerk (Pos. ①, Abb. 16), ohne sie jedoch herauszuziehen.

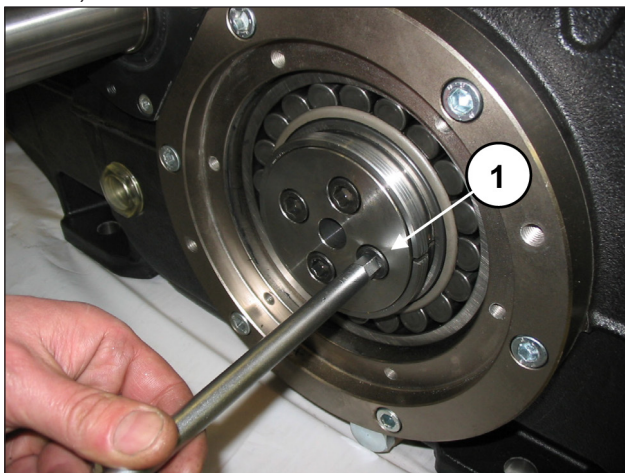
Wiederholen Sie den Vorgang an der gegenüberliegenden Seite.

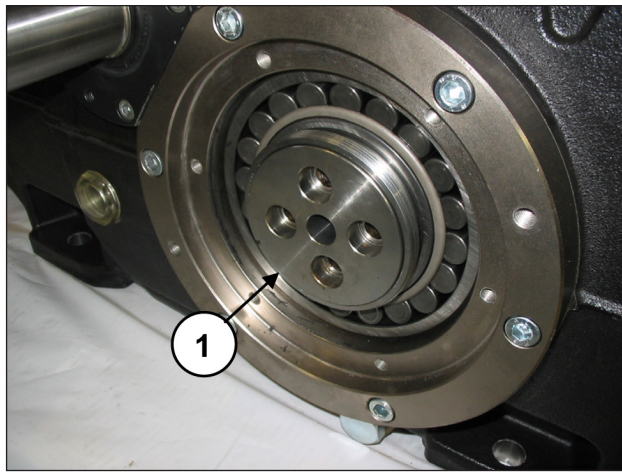

Abb. 15



Abb. 16

Nehmen Sie die Passscheibe unter dem Schaft der mittleren Pleuelstange ab.

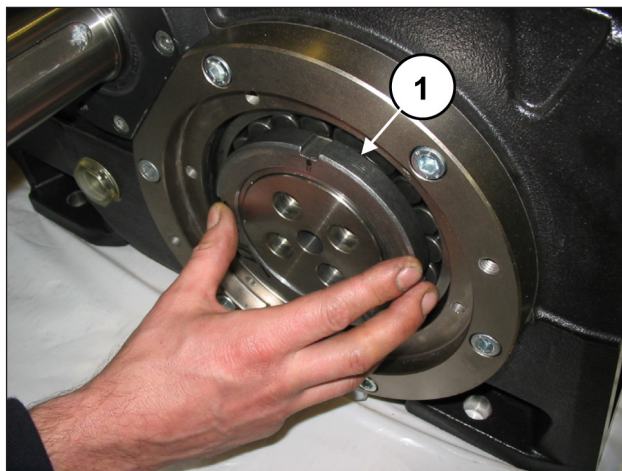
Lösen Sie die Schrauben der Pleuelstange (Pos. ①, Abb. 17).

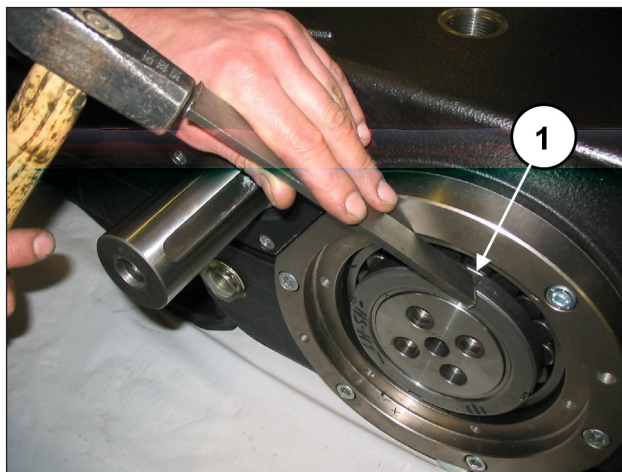

Abb. 17

Demontieren Sie die Pleueldeckel samt Lagerschalen und achten Sie dabei genau auf die Ausbaureihenfolge.

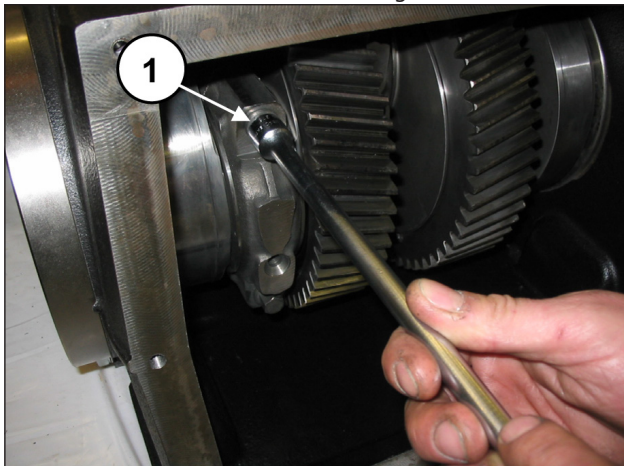

Pleueldeckel und Pleuelhälften müssen in der gleichen Paarungs- und Ausbaureihenfolge wieder eingebaut werden.

Um Fehler zu vermeiden, sind Pleueldeckel und Pleuelhälften auf einer Seite nummeriert (Pos. ①, Abb. 18).



Abb. 18

Schieben Sie die drei Pleuelhälften soweit wie möglich in Richtung Kopf vor.

Ziehen Sie die drei Lagerschalen der Pleuelhälften ab (Pos. ①, Abb. 19).

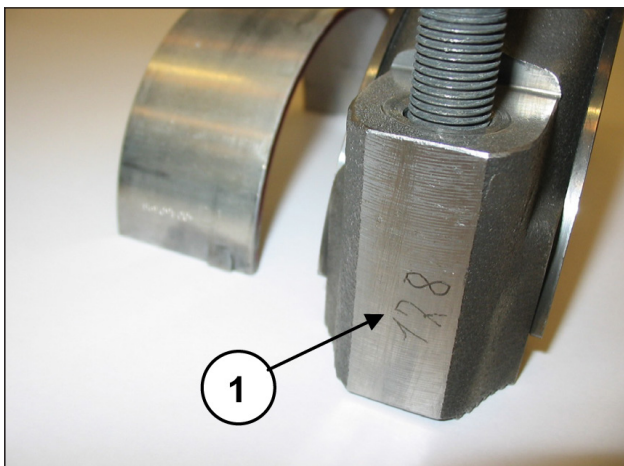
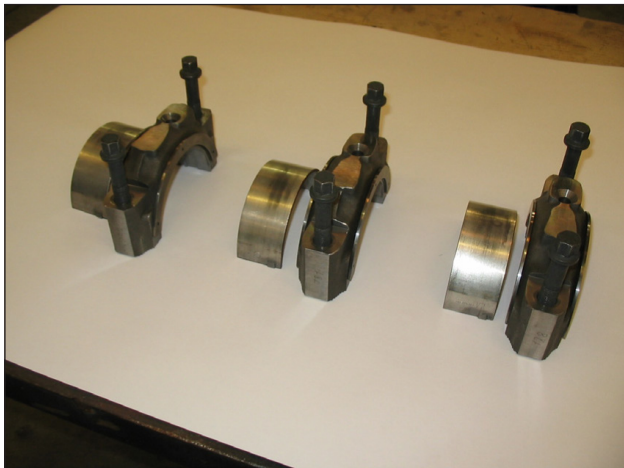

Abb. 19

Nehmen Sie beide Druckbuchsen ab (Pos. ①, Abb. 20).

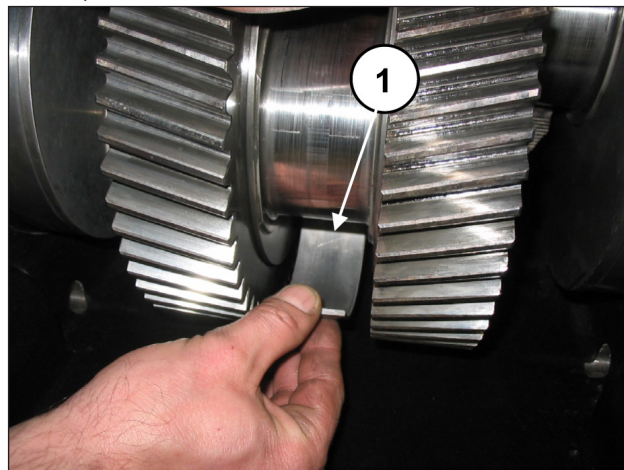

Abb. 20

Trennen Sie den Buchsenflansch von der Druckbuchse (Pos. ①, Abb. 21).

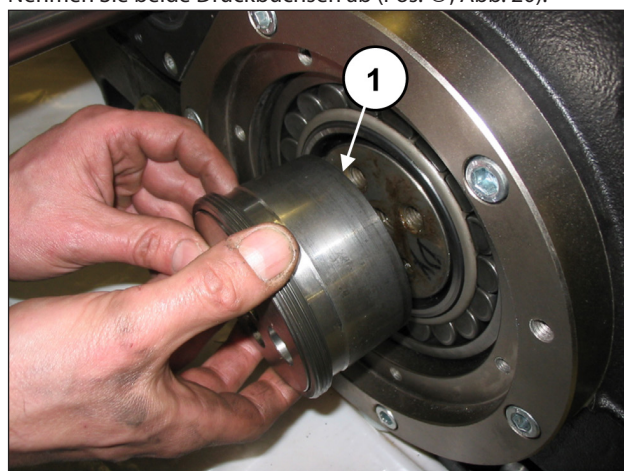

Abb. 21

Lösen Sie die Schrauben der zwei Lagerdeckel (Pos. ①, Abb. 22).

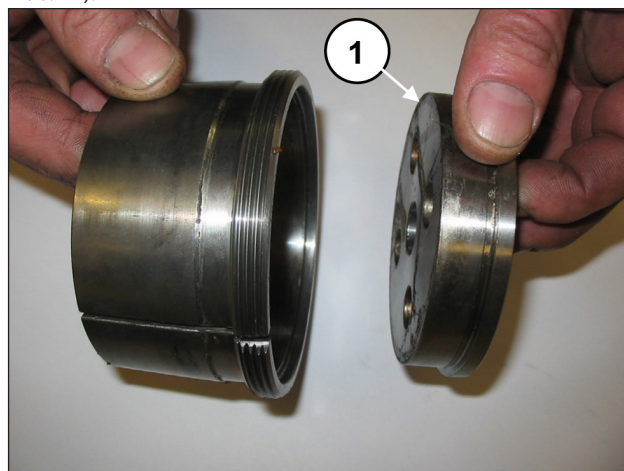

Abb. 22

Setzen Sie einen Gewindestift M16 an ein Ende der Kurbelwelle (Pos. ①, Abb. 23) und ziehen Sie bei angehobener Welle den Lagerdeckel samt Lager und O-Ring heraus (Pos. ①, Abb. 24). Zum leichteren Ausbau verwenden Sie 2 Stiftschrauben oder Schrauben M10 (Pos. ②, Abb. 23) als Abzieher.

Wiederholen Sie den Vorgang an der gegenüberliegenden Seite.

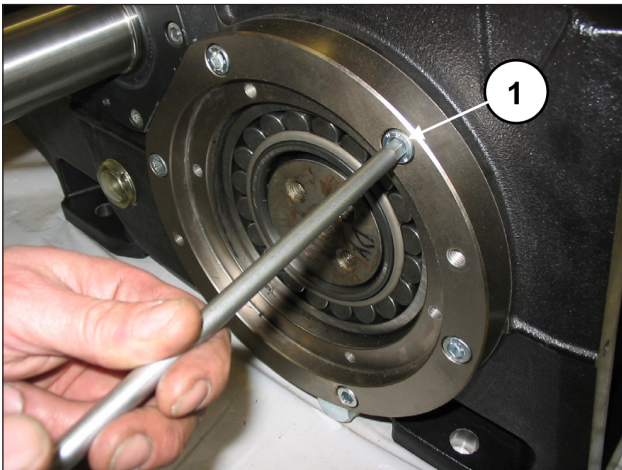

Abb. 23



Abb. 24

Legen Sie die Kurbelwelle auf den Gehäuseboden ab.

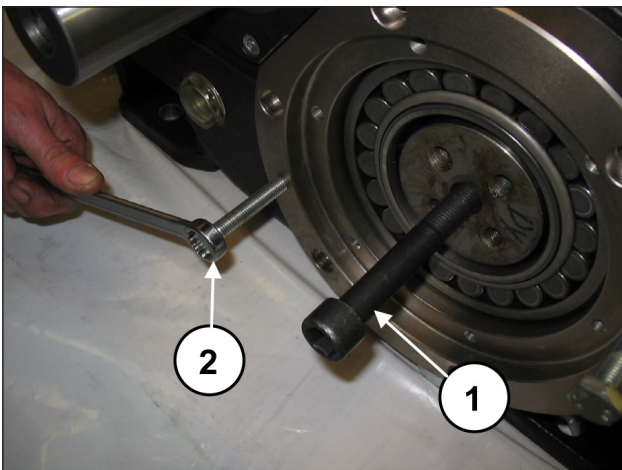
Trennen Sie den Lagerdeckel vom Lager mithilfe eines Werkzeugs mit Schlagwerk (Pos. ①, Abb. 25).

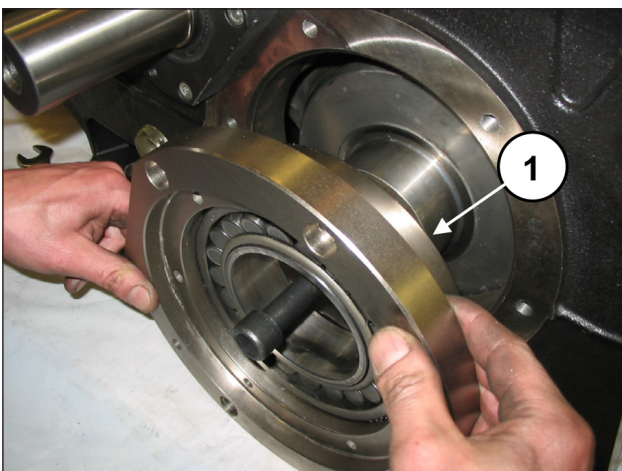

Abb. 25

Lösen Sie die Befestigungsschrauben des rechten und linken Zapfwellen-Lagerdeckels (Pos. ①, Abb. 26) und ziehen Sie die beiden Deckel von der Zapfwelle ab. Zum leichteren Ausbau verwenden Sie 3 Stiftschrauben oder Schrauben M8 (Pos. ①, Abb. 27) als Abzieher.



Abb. 26

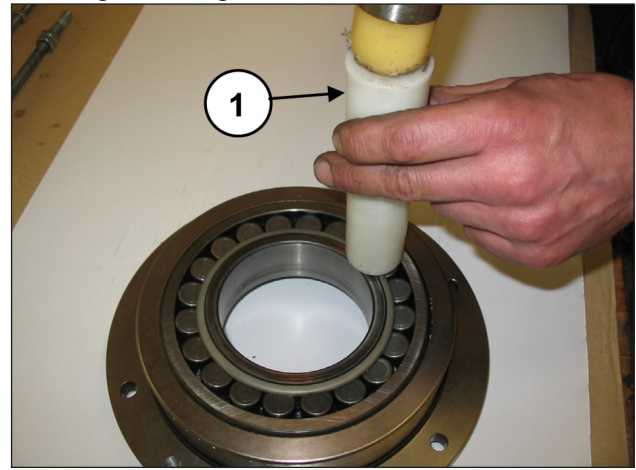

Abb. 27

Entfernen Sie den radialen Dichtring (Pos. ①, Abb. 28) den äußeren O-Ring (Pos. ①, Abb. 29) und den O-Ring der Schmierbohrung (Pos. ①, Abb. 30).

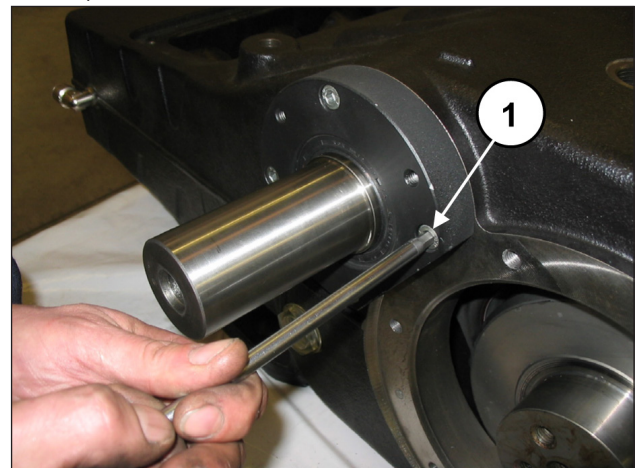

Abb. 28

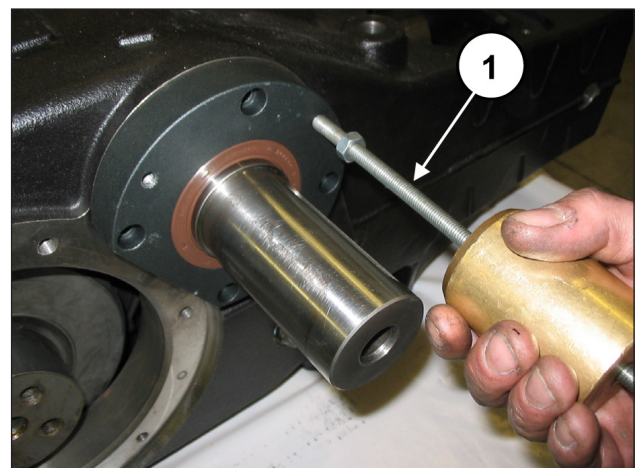

Abb. 29

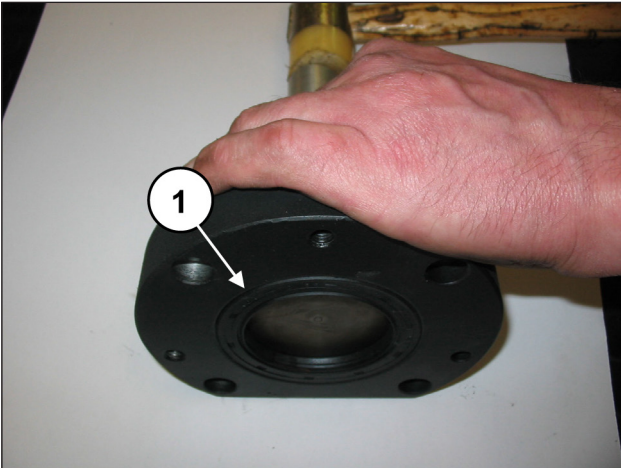

Abb. 30

Schieben Sie die drei Pleuelstangen so weit wie möglich zurück (auf Anschlag mit der Pleuellagerbohrung).

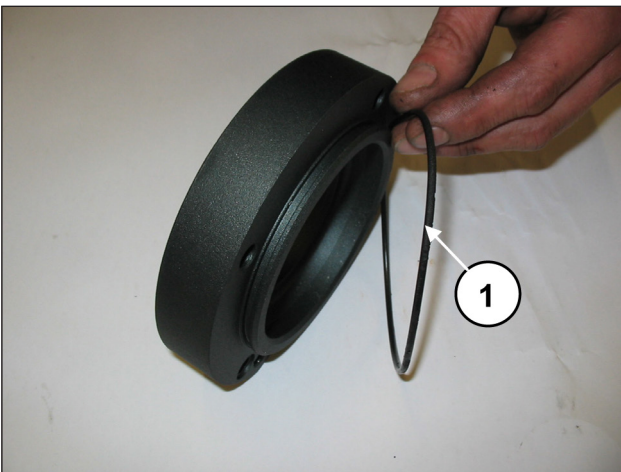
Mithilfe eines Werkzeugs mit Schlagwerk (Pos. ①, Abb. 31) ziehen Sie die Zapfwelle wahlweise von einer der beiden Seiten heraus (Pos. ①, Abb. 32).

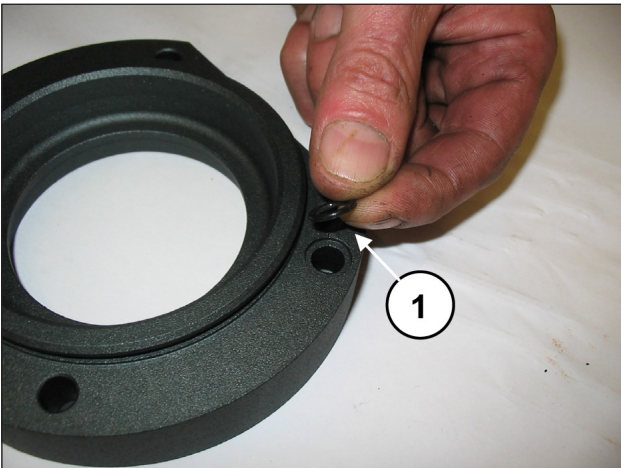

Abb. 31



Abb. 32

Entfernen Sie die Innenringe der Lager von der Zapfwelle (Pos. ①, Abb. 33) und die beiden Distanzringe des Innenlagers (Pos. ②, Abb. 33).

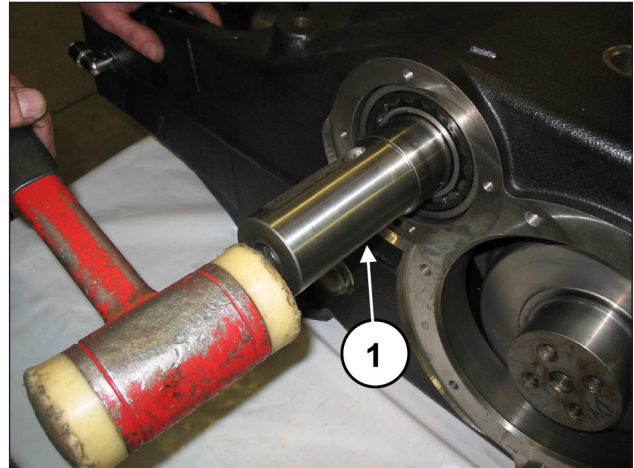

Abb. 33

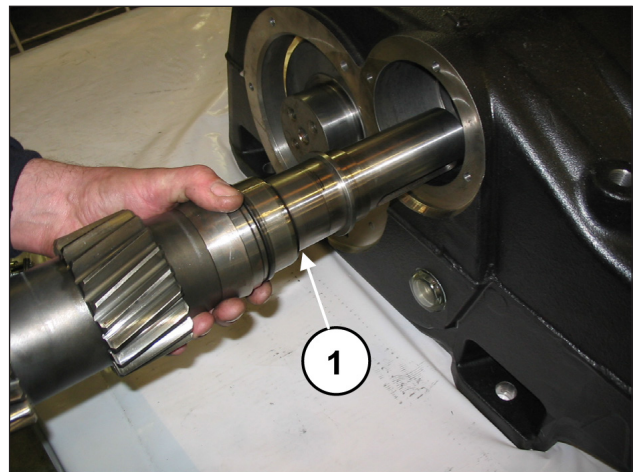

Die Innen- und Außenringe der Lager müssen genau in der gleichen Reihenfolge und Ausbaupaarung wieder eingebaut werden.

Ziehen Sie mithilfe einer ausreichend langen Stange (Pos. ①, Abb. 34) und eines Schlagwerks die Lagerringe vom Pumpengehäuse (Pos. ①, Abb. 35), den Distanzring des Außenlagers (Pos. ①, Abb. 36) und die Schmierbuchse der Lager ab (Pos. ①, Abb. 37).

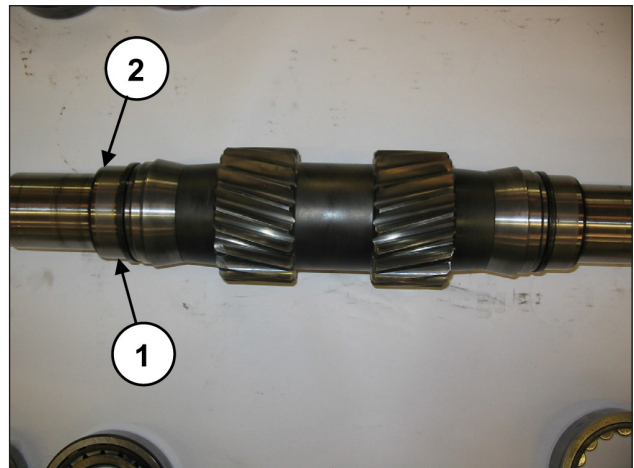

Abb. 34



Abb. 35

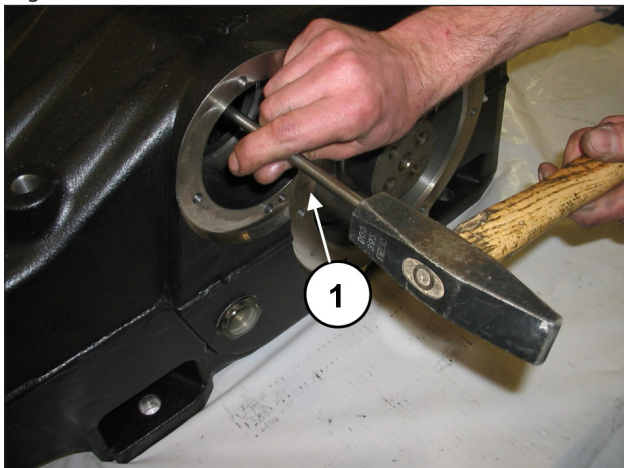

Abb. 36

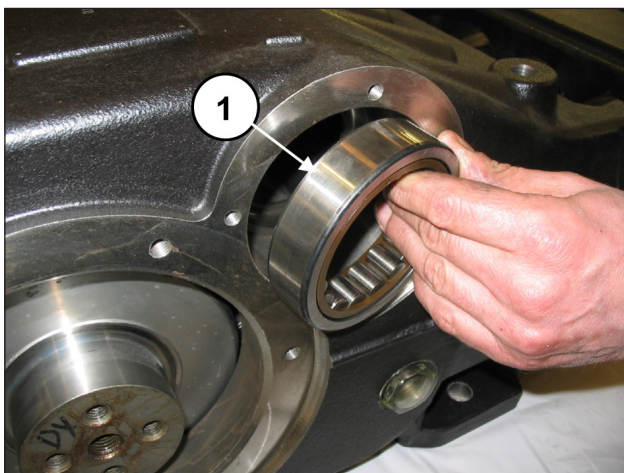

Abb. 37

Schieben Sie die Pleuelhälften in Richtung Hydraulik vor und sichern Sie diese mit dem entsprechenden Werkzeug (Art. 27566200) (Pos. ①, Abb. 38).

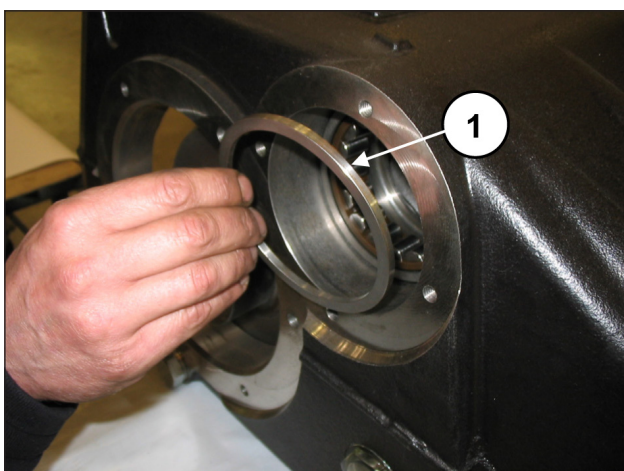

Abb. 38

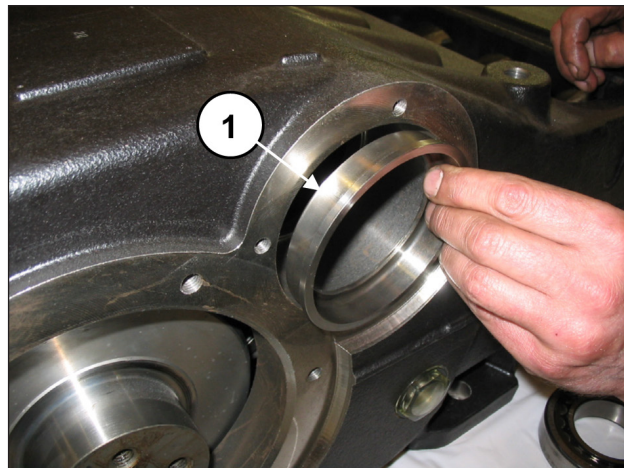
Entnehmen Sie die Pleuelwelle von der Rückseite des Gehäuses (Pos. ①, Abb. 39).

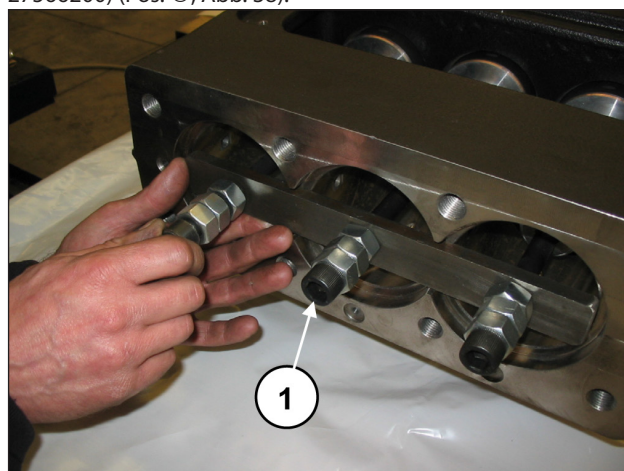

Abb. 39

Drehen Sie die Schrauben des Werkzeugs Art. 27566200 zum Lösen der Pleuelstangen ab (Pos. ①, Abb. 40) und ziehen Sie anschließend die Baugruppe Pleuelstange-Kolbenführung von der hinteren Gehäuseöffnung heraus (Pos. ①, Abb. 41).



Abb. 40

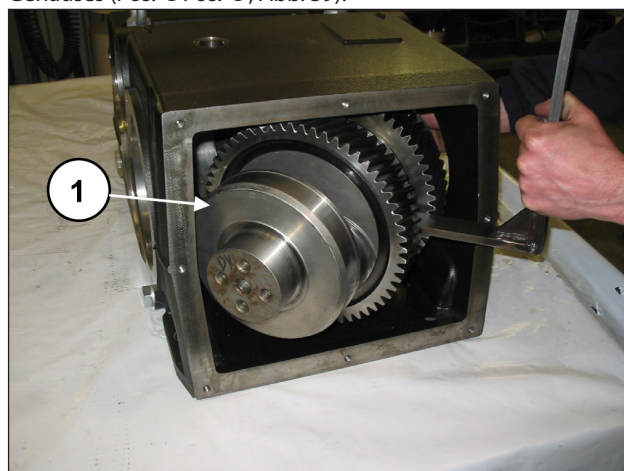

Abb. 41

Paaren Sie die Pleuelhälften mit dem vorab ausgebauten Pleueldeckeln unter Berücksichtigung der Nummerierung (Pos. ①, Abb. 42).

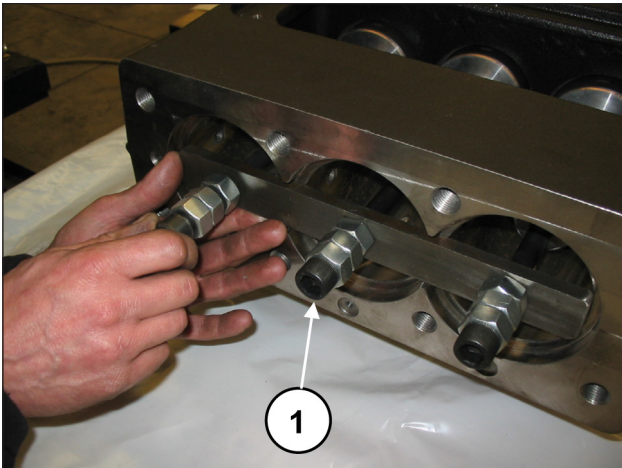

Abb. 42

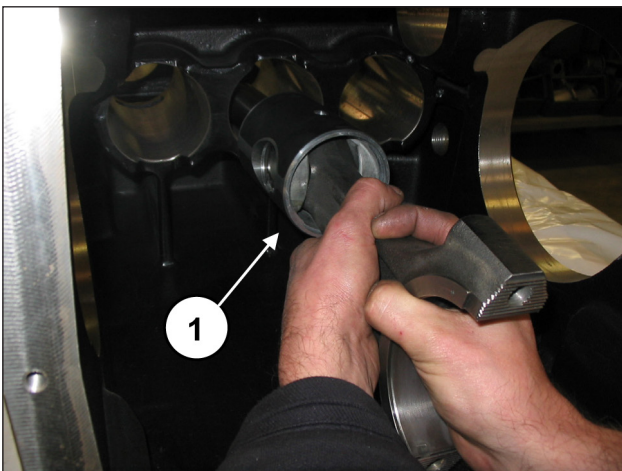
Entfernen Sie die zwei Seegerringe zur Sicherung des Bolzens mit einem geeigneten Werkzeug (Pos. ①, Abb. 43).

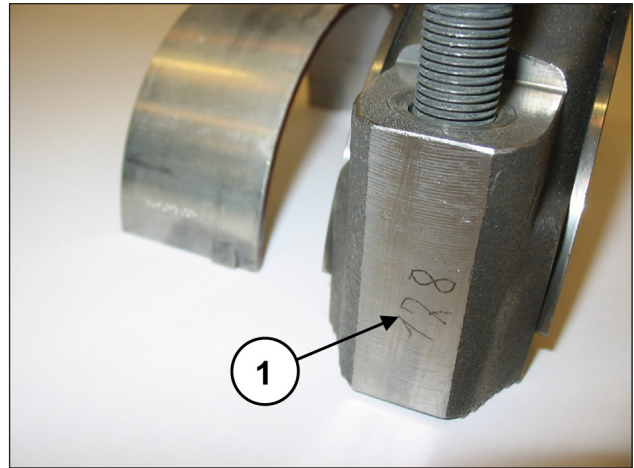
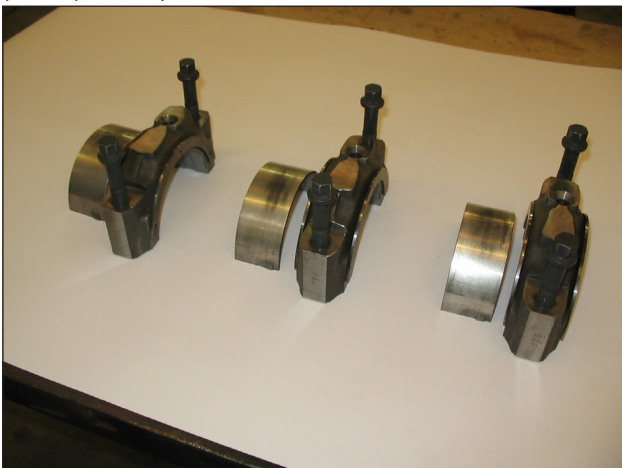

Abb. 43

Streifen Sie den Bolzen ab (Pos. ①, Abb. 44) und ziehen Sie die Pleuelstange heraus (Pos. ①, Abb. 45).



Abb. 44

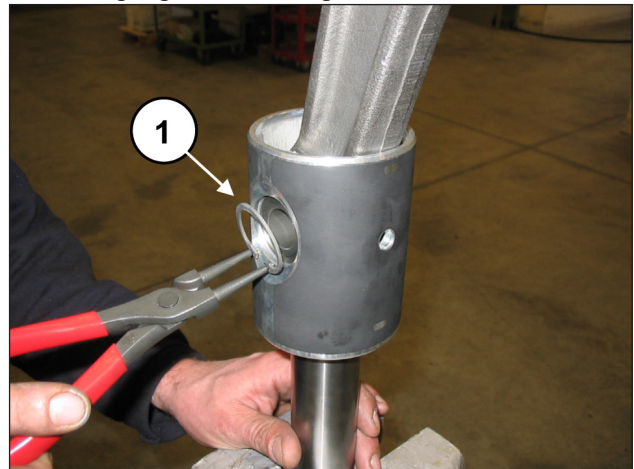

Abb. 45

Drehen Sie zum Trennen der Stange von der Kolbenführung die Zylinderkopfschrauben M6 mit dem entsprechenden Schlüssel ab (Pos. ①, Abb. 46).

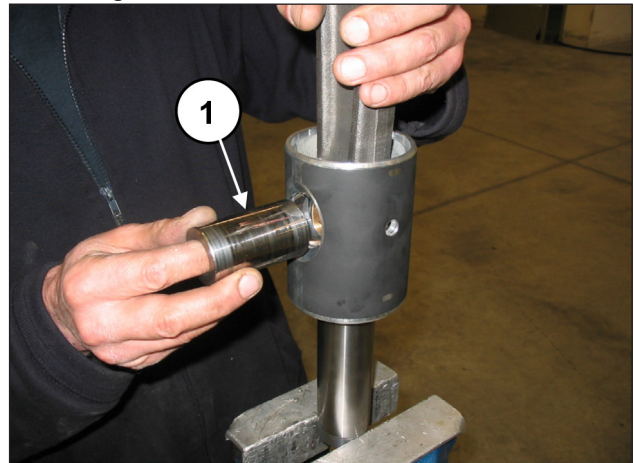

Abb. 46

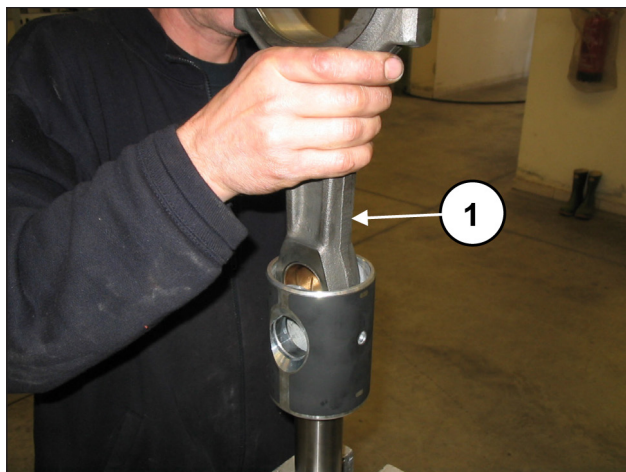
Beenden Sie den Ausbau der Mechanik, indem Sie die Ölstand-Schaugläser und die Hubösen abnehmen.

2.1.2 Einbau der Mechanik

Verfahren Sie für den Einbau in umgekehrter Reihenfolge zu den Angaben in Abschn. 2.1.1.

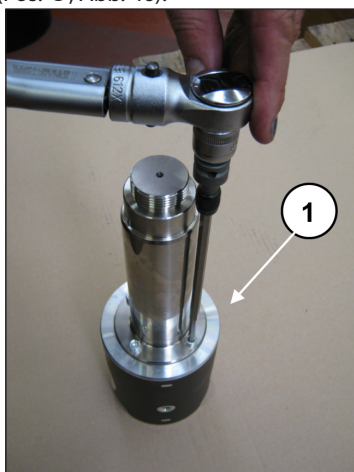
Die vorgeschriebene Arbeitsabfolge lautet:

Montieren Sie die beiden Ölstand-Schaugläser, die zwei Ölablassverschlüsse und den 90° Steckanschluss (Pos. ①, ② und ③ Abb. 47).



Abb. 47

Montieren Sie die Stange an die Kolbenführung.

Setzen Sie die Kolbenführungsstange in die entsprechende Aufnahme an der Kolbenführung ein (Pos. ①, Abb. 48) und befestigen Sie die Stange mit den 4 Zylinderkopfschrauben M6x20 (Pos. ①, Abb. 49).

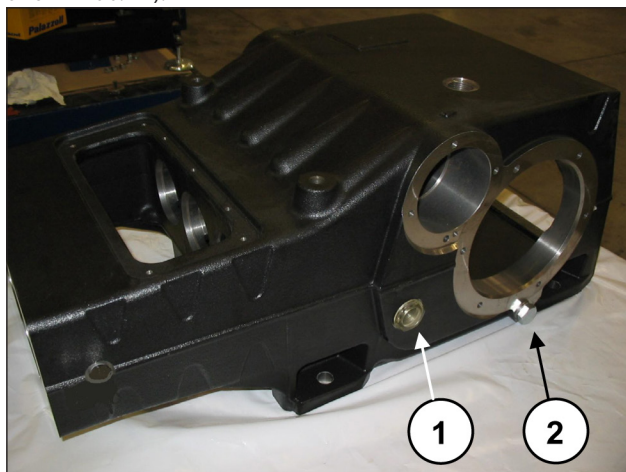

Abb. 48



Abb. 49

Spannen Sie die Kolbenführung mithilfe des speziellen Werkzeugs in einen Schraubstock und eichen Sie die Schrauben mit einem Drehmomentschlüssel (Pos. ①, Abb. 50) gemäß Angaben in Kapitel 3.



Abb. 50

Setzen Sie die Pleuelstange in die Kolbenführung ein (Pos. ①, Abb. 45) und anschließend den Bolzen (Pos. ①, Abb. 44). Montieren Sie die zwei Seegeringe zur Sicherung mit dem entsprechenden Werkzeug (Pos. ①, Abb. 43).

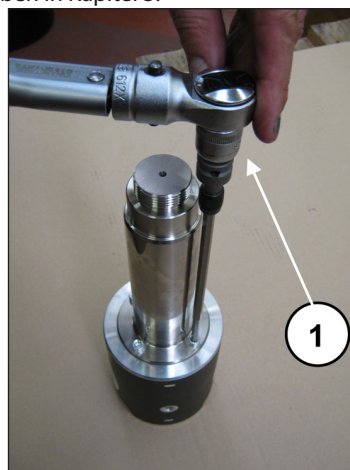

Der Einbau ist korrekt, wenn Pleuelauge, Kolbenführung und Bolzen freigängig drehen.

Trennen Sie Pleueldeckel und Pleuelhälften; die vorschriftsmäßige Paarung wird durch die seitliche Nummerierung garantiert (Pos. ①, Abb. 42). Nachdem Sie das Gehäuse auf perfekte Sauberkeit überprüft haben, setzen Sie die Baugruppe Pleuelhälfte-Kolbenführung in die Buchsen des Gehäuses ein (Pos. ①, Abb. 41).



Beim Einsetzen der Baugruppe Pleuelhälfte-Kolbenführung in das Gehäuse müssen die Pleuelhälften mit nach oben sichtbarer Nummerierung ausgerichtet werden.

Arretieren Sie die drei Baugruppen mit dem entsprechenden Werkzeug Art. 27566200 (Pos. ①, Abb. 40).

Führen Sie die Kurbelwelle durch die hintere Gehäuseöffnung ein und legen Sie diese auf dem Boden ab.



Achten Sie beim Einschieben der Kurbelwelle in das Gehäuse auf die Ausrichtung der Zahnkranzverzahnung lt. Abb. 51.



Abb. 51

Montieren Sie vorläufig die Zapfwelle: setzen Sie die 2 Innenringe der Lager (einen pro Seite) auf die Zapfwelle (Pos. ①, Abb. 52).



Abb. 52

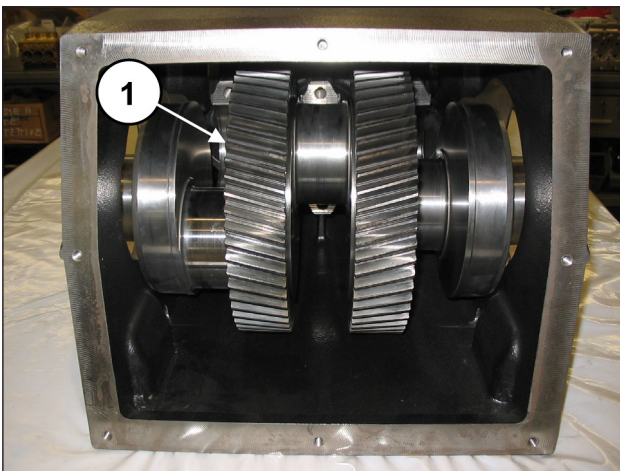

Die Innen- und Außenringe der Lager müssen genau in der gleichen Reihenfolge und Ausbaupaarung wieder eingebaut werden.

Treiben Sie auf einer Gehäuseseite die Schmierbuchse der Lager (Pos. ①, Abb. 53) und einen Außenring des Lagers (Pos. ①, Abb. 54) mithilfe eines Dorns mit Schlagwerk ein.

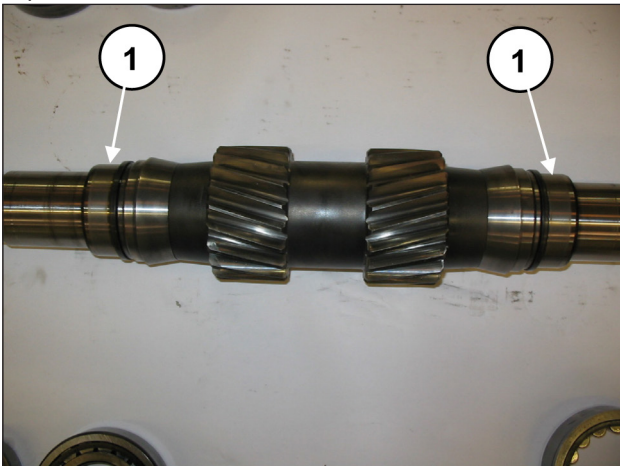

Abb. 53



Abb. 54

Entfernen Sie das Werkzeug zur Sicherung der Pleuelstangen Art. 27566200 (Pos. ①, Abb. 40) und schieben Sie die Pleuelstangen bis auf Anschlag mit der Kurbelwelle zurück. Bauen Sie die vormontierte Zapfwelle in das Gehäuse ein (Pos. ①, Abb. 55), u.z. auf der entgegengesetzten Seite zum vorab montieren Außenring des Lagers und zur Schmierbuchse der Lager.

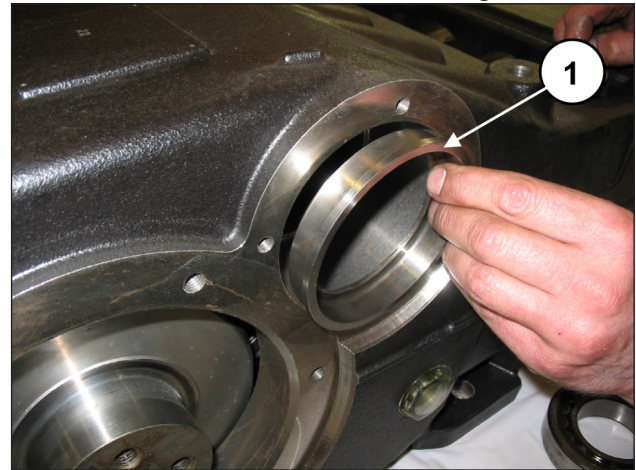

Achten Sie beim Einschieben der Zapfwelle in das Gehäuse auf die Ausrichtung der Verzahnung lt. Abb. 55.

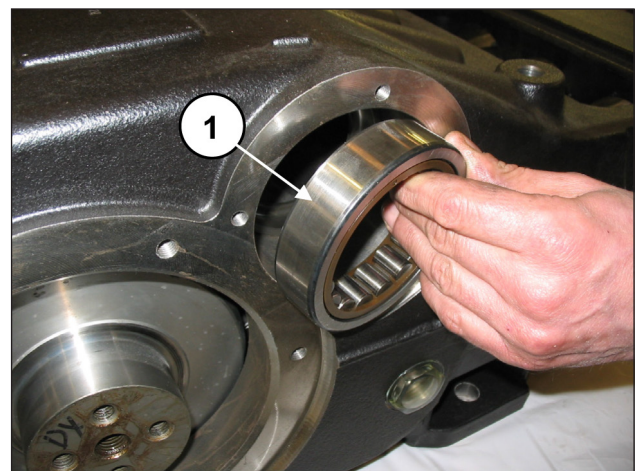
Zum leichteren Einsetzen der Zapfwelle in das Lager können Sie eine Schraube M16 an das einzuführende Wellenende anbringen, um die Welle dadurch anzuheben (Pos. ①, Abb. 56).



Abb. 55



Abb. 56

Treiben Sie auf der Einbauseite der Zapfwelle die Schmierbuchse der Lager (Pos. ①, Abb. 57) und einen Außenring des Lagers (Pos. ①, Abb. 58) mithilfe eines Dorns mit Schlagwerk ein.

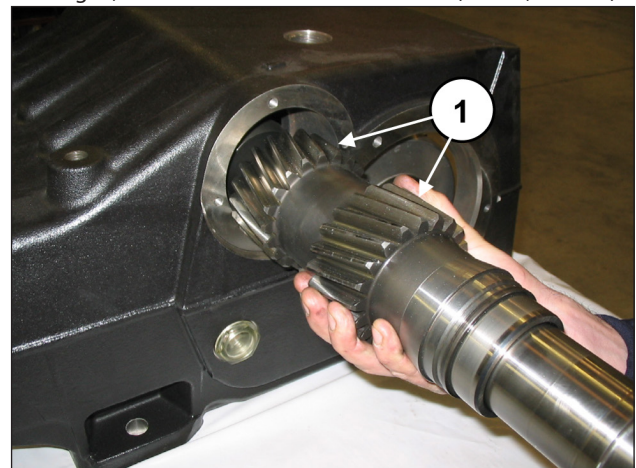

Abb. 57

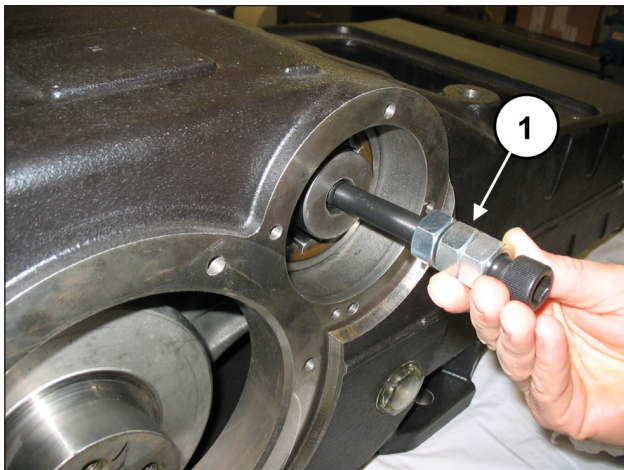

Abb. 58

Setzen Sie auf beiden Seite den inneren Distanzring des Lagers (Pos. ①, Abb. 59) und den äußeren Ring ein (Pos. ①, Abb. 60).



Abb. 59

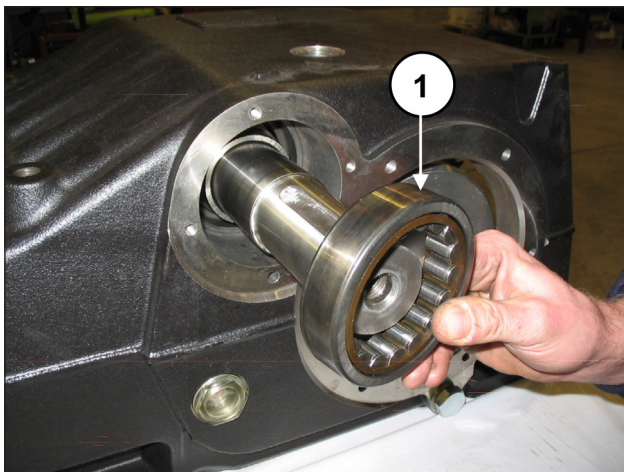

Abb. 60

Setzen Sie den Innenring (Pos. ①, Abb. 61) und den Außenring (Pos. ①, Abb. 62) eines Lagers nur auf einer Pumpenseite ein.

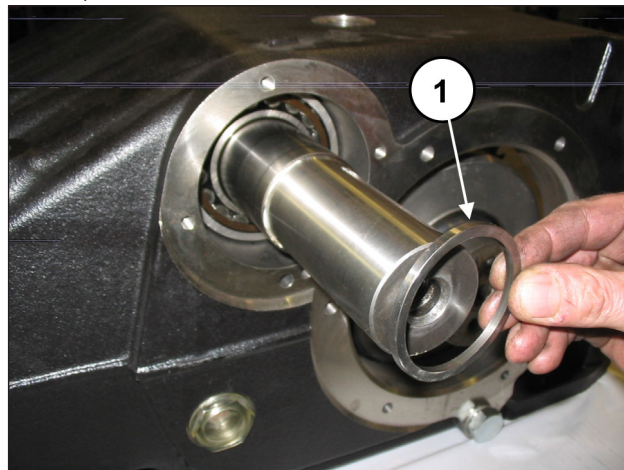

Abb. 61

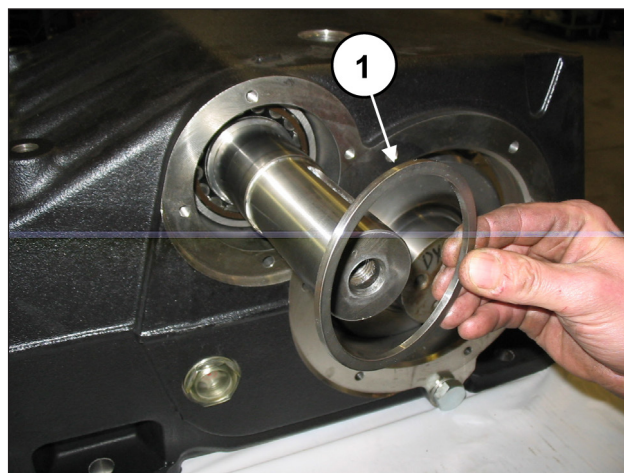

Abb. 62

Montieren Sie vorläufig den rechten und linken Zapfwellendeckel:

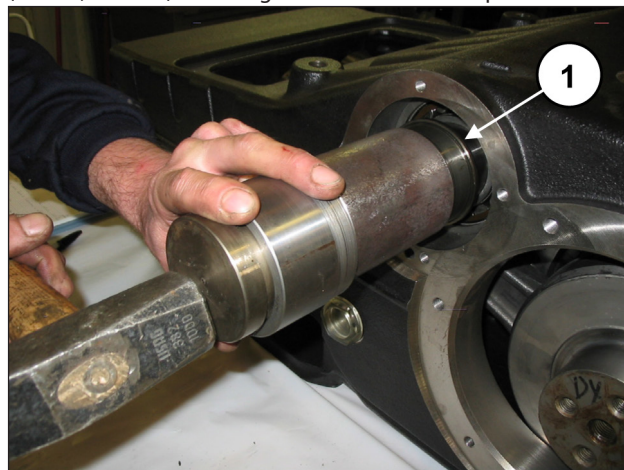
Setzen Sie den radialen Dichtring in den Zapfwellen-Lagerdeckel ein. Verwenden Sie hierfür das Werkzeug Art. 27539500 (Pos. ①, Abb. 63).

Überprüfen Sie vor Einbau des radialen Dichtrings den Zustand der Dichtlippe. Im Fall eines Austauschs montieren Sie den neuen Ring gemäß Abb. 64.

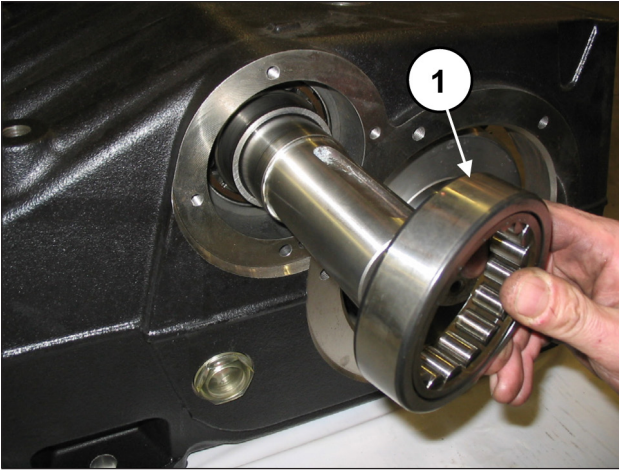

Sollte die Zapfwelle im Bereich mit der Dichtlippe einen Verschleiß am Durchmesser aufweisen, können Sie zur Vermeidung der Schleifbearbeitung den Ring auf Anschlag mit dem Deckel neu ausrichten, siehe hierzu Abb. 64.



Abb. 63



Abb. 64

Setzen Sie auf die Zapfwellen-Lagerdeckel den äußeren O-Ring (Pos. ①, Abb. 65) und den O-Ring der Schmierbohrung (Pos. ①, Abb. 66).

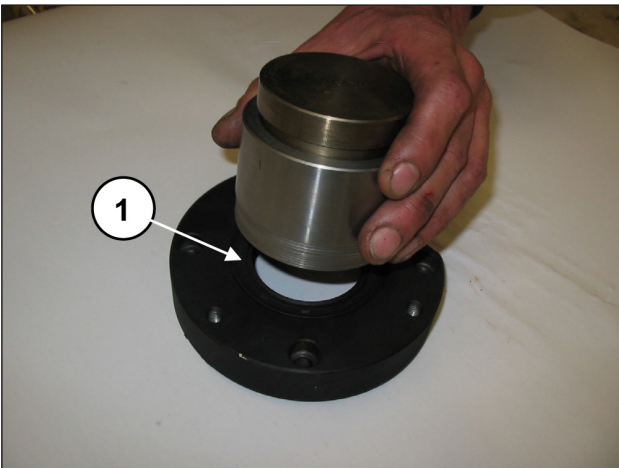

Abb. 65

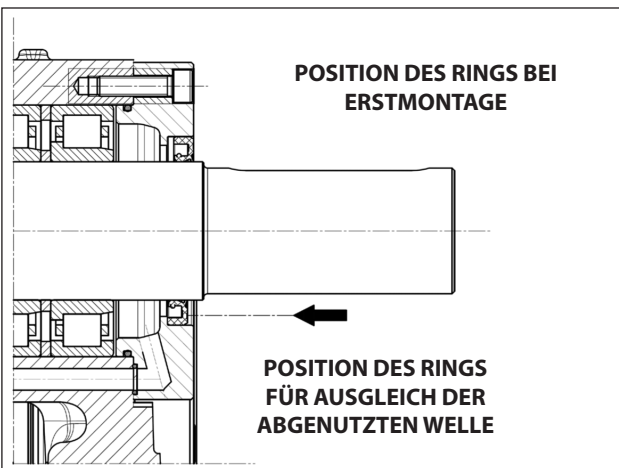

Abb. 66

Montieren Sie einen ersten Zapfwellen-Lagerdeckel (rechts bzw. links) an das Pumpengehäuse (Pos. ①, Abb. 67) und befestigen Sie den Deckel anhand von 4 Schrauben M8x30 (Pos. ①, Abb. 68).

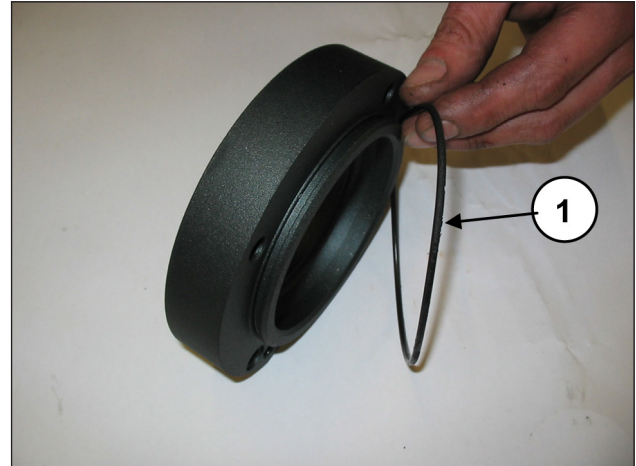

Achten Sie auf den richtigen Einbausinn des Deckels. Die Schmierbohrung des Deckels muss mit der Bohrung am Gehäuse zusammenfallen.

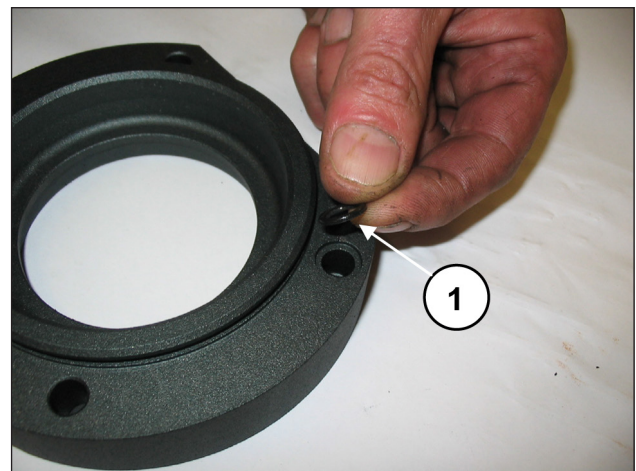

Abb. 67



Abb. 68

Wiederholen Sie die Schritte an der gegenüberliegenden Seite.

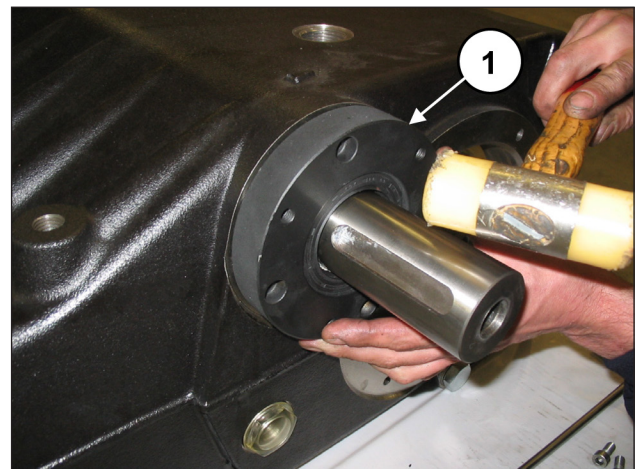
Setzen Sie den Innenring (Pos. ①, Abb. 61) und den Außenring (Pos. ①, Abb. 62) des letzten Lagers ein.

Montieren Sie den fehlenden Zapfwellen-Lagerdeckel an das Pumpengehäuse (Pos. ①, Abb. 67) und befestigen Sie den Deckel anhand von 4 Schrauben M8x30 (Pos. ①, Abb. 68).

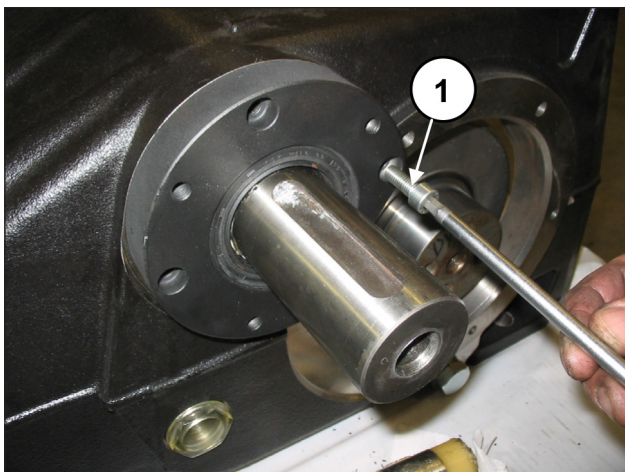
Eichen Sie die 4+4 Schrauben mit einem Drehmomentschlüssel, wie in Kapitel 3 gezeigt.

Montieren Sie vorläufig die beiden Lagerdeckel: setzen Sie das Lager mit dem Schlagwerk (Pos. ①, Abb. 69) bis auf ein Maß von 4÷4.5 mm ein, siehe Abb. 70.



Abb. 69



Abb. 70



Das Lager in Abb. 70 verfügt über einen konischen Innenring. Vergewissern Sie sich vor Einsetzen der Buchse, dass die Konizität von außen nach innen verläuft.

Montieren Sie den O-Ring außen am Lagerdeckel (Pos. ①, Abb. 71).

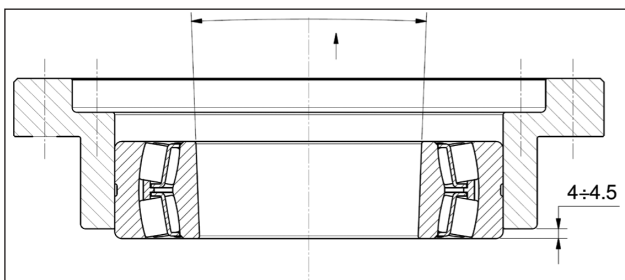

Abb. 71

Wiederholen Sie den Vorgang beim anderen Deckel. Arretieren Sie die drei Pleuelgruppen mit dem entsprechenden Werkzeug Art. 27566200 (Pos. ①, Abb. 40). Setzen Sie zwei Gewindestifte M16 an das Ende der Kurbelwelle und treiben Sie bei angehobener Welle (Pos. ①, Abb. 72) den Lagerdeckel samt Lager und O-Ring (Pos. ①, Abb. 73) mithilfe eines Schlagwerks ein. Wiederholen Sie den Vorgang an der gegenüberliegenden Seite.



Abb. 72

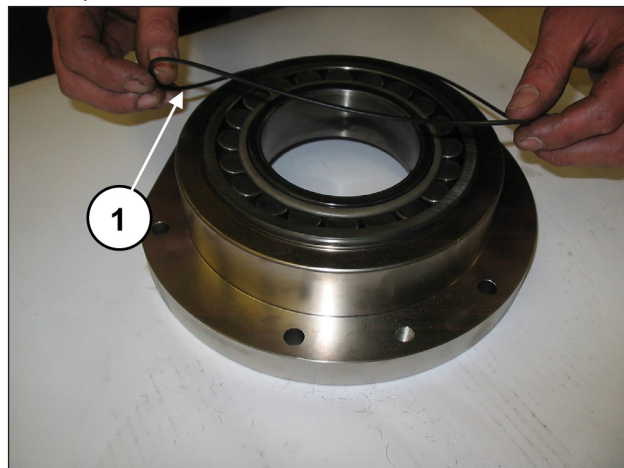

Abb. 73

Befestigen Sie die Lagerdeckel anhand von 6+6 Schrauben M10x30 (Pos. ①, Abb. 74).
Eichen Sie die Schrauben mit einem Drehmomentschlüssel, wie in Kapitel 3 gezeigt.

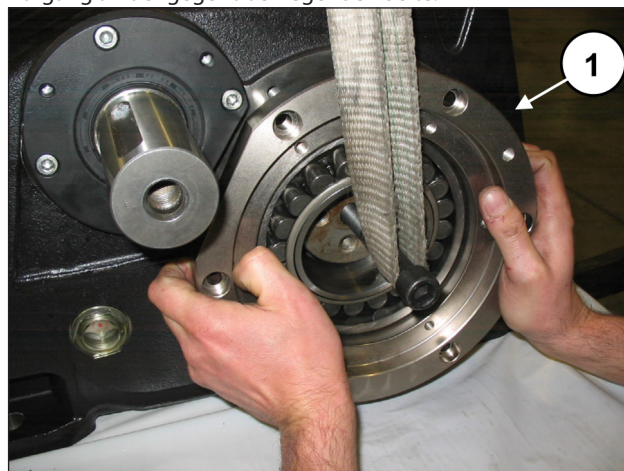

Abb. 74

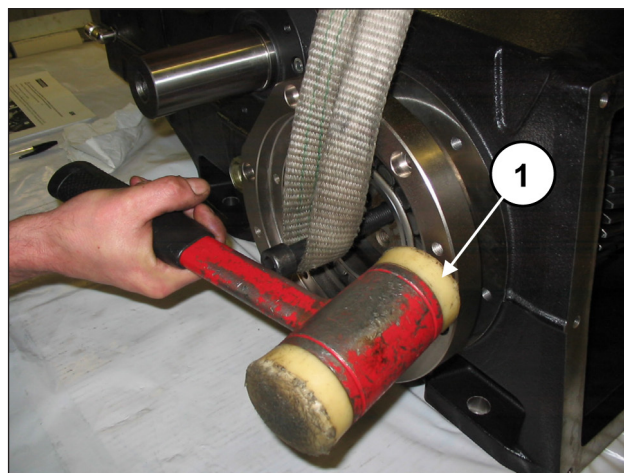
Setzen Sie die zwei Druckbuchsen teilweise ein und halten Sie hierbei die Kurbelwelle mit dem vorab montierten Stift M16 angehoben (Pos. ①, Abb. 75).

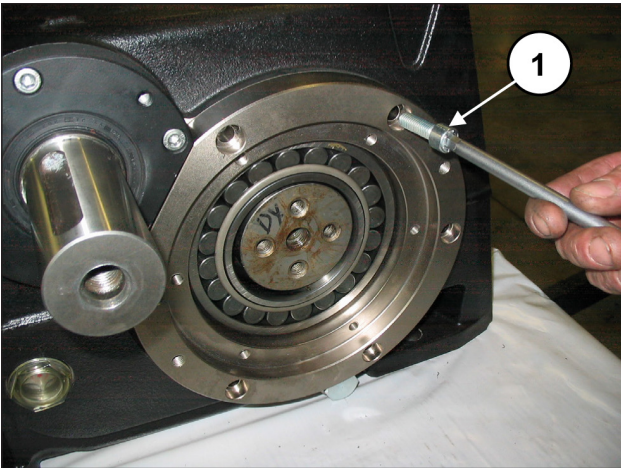

Abb. 75

Treiben Sie die Druckbuchse vollständig auf die Kurbelwelle (Pos. ①, Abb. 76 e Abb. 77) mithilfe eines Schlagwerks und eines Dorns ein.



Abb. 76

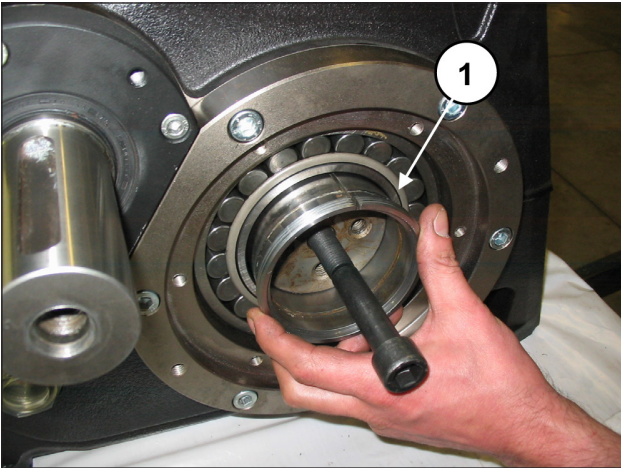

Abb. 77

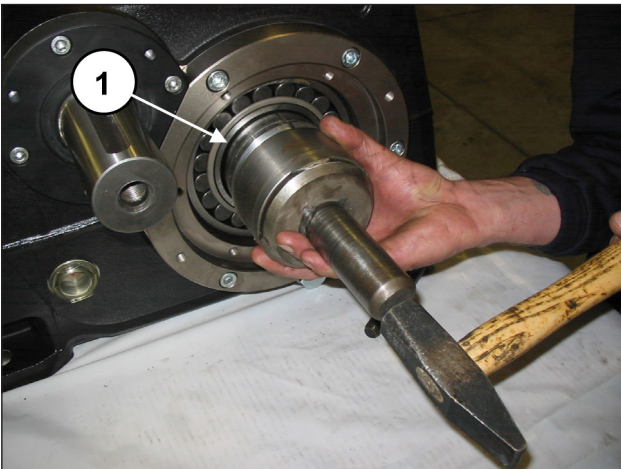

Setzen Sie die Druckbuchse trocken (ohne Öl oder Schmierstoff ein).

Setzen Sie die Buchse soweit ein, bis sich die Außenfläche (konisch) perfekt mit der Innenseite des Lagers verbindet. Achten Sie beim Einsetzen darauf, dass das Lager mit dem Bund der Kurbelwelle in Kontakt bleibt.

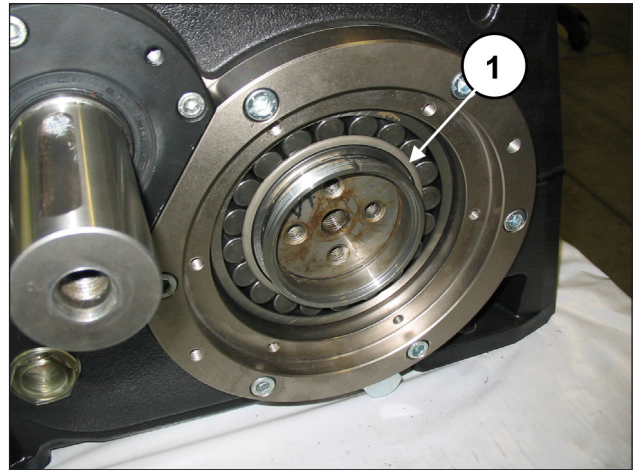
Wiederholen Sie den Vorgang an der gegenüberliegenden Seite.

Setzen Sie die Buchsenflansche in die konischen Buchsen ein (Pos. ①, Abb. 78).

Drehen Sie eine Schraube M16 ausreichender Länge (35-40 mm) in die Bohrung M16 der Kurbelwelle bis zur kompletten Auflage des Flanschs an der Buchse ein (Pos. ①, Abb. 79).
Ziehen Sie die Schraube nicht fest.



Abb. 78



Abb. 79

Wiederholen Sie den Vorgang an der gegenüberliegenden Seite.

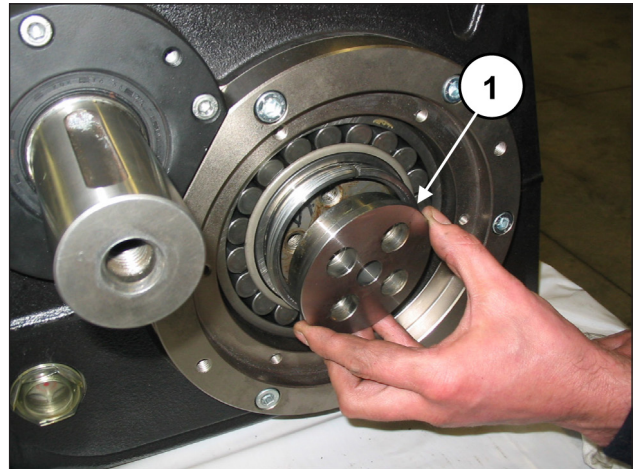
Entfernen Sie das Werkzeug zur Sicherung der Pleuelstangen Art. 27566200 (Pos. ①, Abb. 40).

Setzen Sie die oberen Lagerschalen zwischen Pleuelstange und Kurbelwelle ein (Pos. ①, Abb. 80).

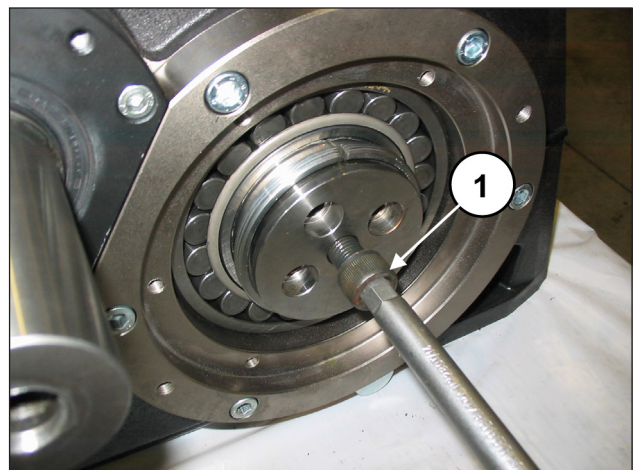

Stellen Sie für einen vorschriftsmäßigen Einbau der Lagerschalen sicher, dass die Bezugsmarkierung der Lagerschalen in der entsprechenden Aufnahme an der Pleuelhälfte zu liegen kommt (Pos. ①, Abb. 81).



Abb. 80



Abb. 81

Montieren Sie die unteren Lagerschalen an die Pleueldeckel (Pos. ①, Abb. 82) und vergewissern Sie sich dabei, dass die Bezugsmarkierung der Lagerschalen in der entsprechenden Aufnahme am Deckel zu liegen kommt (Pos. ②, Abb. 82).

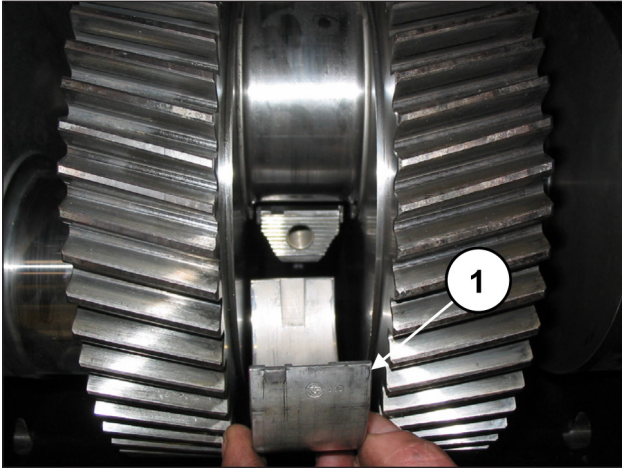
Befestigen Sie die Pleueldeckel mit Pleuelhälften anhand der Schrauben M12x1.25x87 (Pos. ①, Abb. 83).

Eichen Sie die Schrauben mit einem Drehmomentschlüssel, wie in Kapitel 3 gezeigt, und ziehen Sie gleichzeitig die Schrauben auf Anzugsmoment fest.

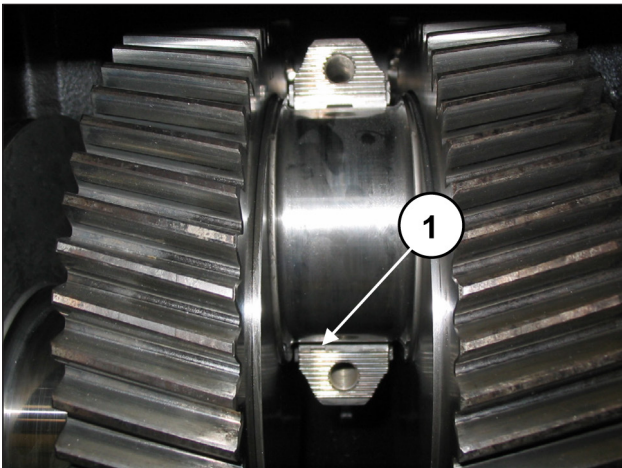

Achten Sie auf den richtigen Einbausinn der Lagerdeckel. Die Nummerierung muss nach oben gerichtet sein.



Abb. 82



Abb. 83

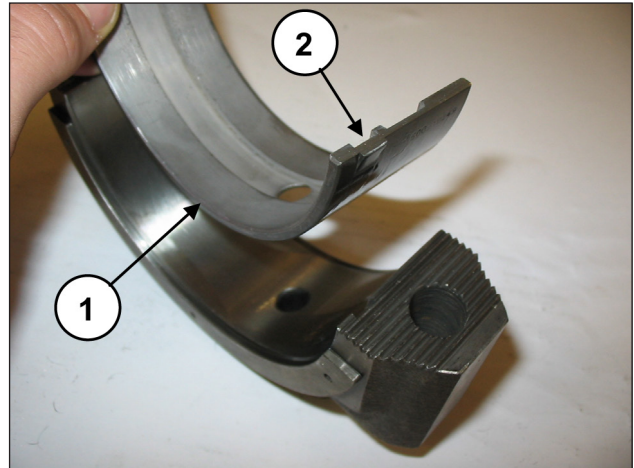

Überprüfen Sie nach abgeschlossenem Vorgang, ob die Pleuelstangen in beiden Richtungen Axialspiel aufweisen.

Setzen Sie eine Passscheibe unter den Schaft der mittleren Pleuelstange, um die Drehung der Kurbelwelle zu kontern (Pos. ①, Abb. 84).

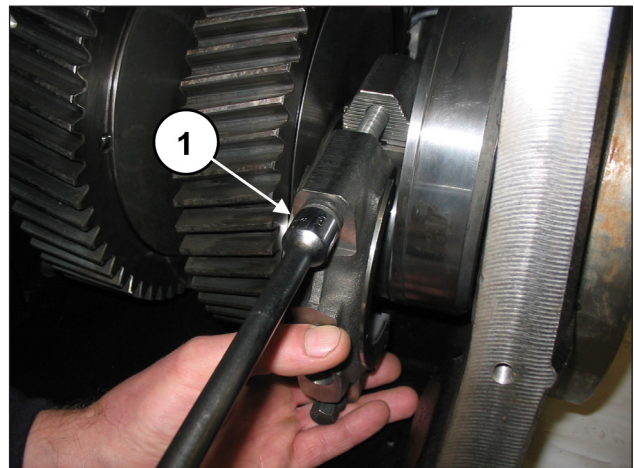

Abb. 84

Messen Sie das Maß "X" in Abb. 85 zwischen konischer Buchse und Kurbelwellenlager.

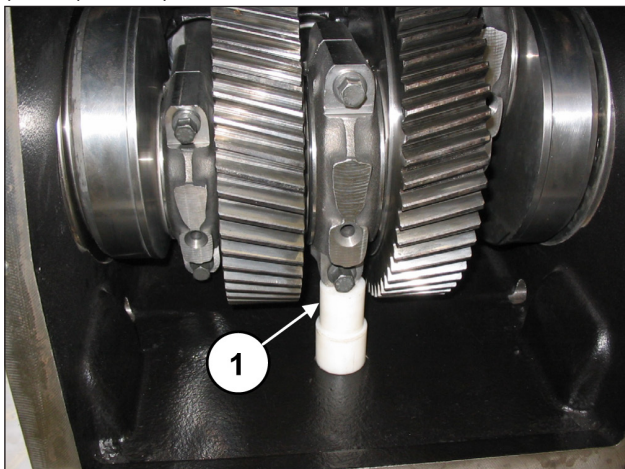

Abb. 85

Drehen Sie die Schraube M16 fest, bis eine Reduzierung des Maßes "X" zwischen 0,7 und 0,8 mm eintritt (Abb. 86).

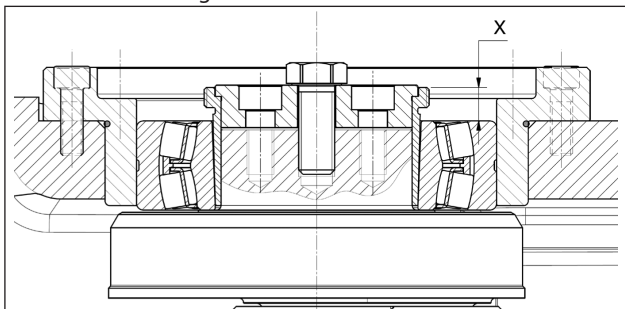

Abb. 86

Wiederholen Sie den Vorgang an der gegenüberliegenden Seite.
Nehmen Sie die Schraube M16 von der Kurbelwelle ab.

Drehen Sie die zwei Buchsenflansche mit den 4+4 Schrauben M12x25 an die Kurbelwelle (Pos. ①, Abb. 88).

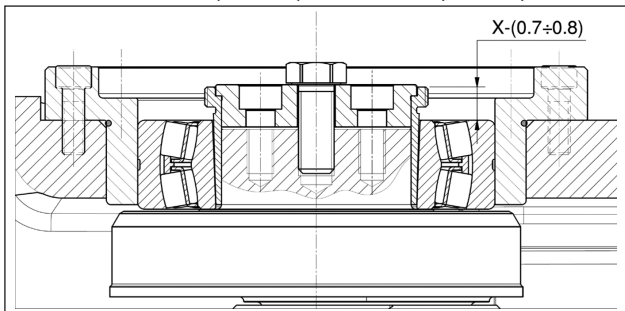

Tragen Sie LOCTITE 243 auf das Gewinde der Schrauben M12x25 (Pos. ①, Abb. 87).

Eichen Sie die Schrauben mit einem Drehmomentschlüssel, wie in Kapitel 3 gezeigt.



Abb. 87



Abb. 88

Nehmen Sie die Drehsicherungsscheibe unter dem Schaft der mittleren Pleuelstange ab.
Montieren Sie die beiden Lagerdeckel (samt O-Ringen) (Pos. ①, Abb. 89), mit 6+6 Schrauben M8x20 (Pos. ①, Abb. 90). Eichen Sie die Schrauben mit einem Drehmomentschlüssel, wie in Kapitel 3 gezeigt.

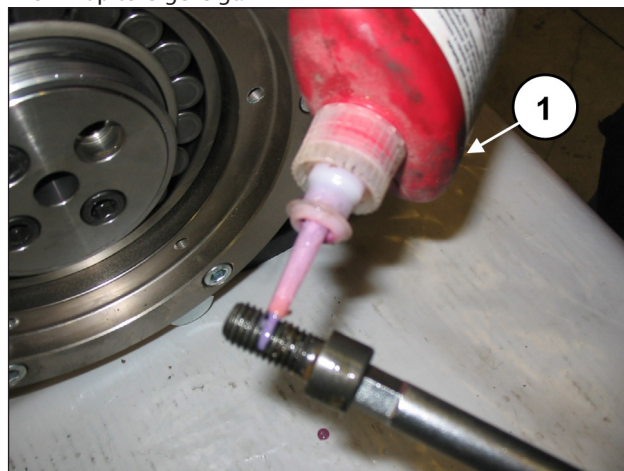

Abb. 89

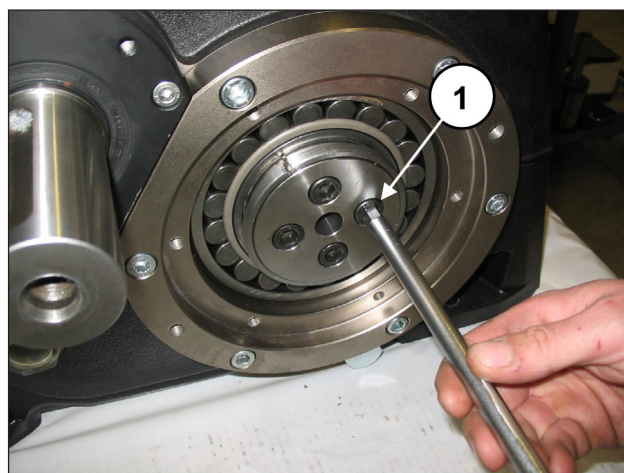

Abb. 90

Setzen Sie den O-Ring in den hinteren Deckel ein (Pos. ①, Abb. 91) und befestigen Sie den Deckel am Gehäuse anhand von 10 Schrauben M8x20 (Pos. ①, Abb. 92). Eichen Sie die Schrauben mit einem Drehmomentschlüssel, wie in Kapitel 3 gezeigt.

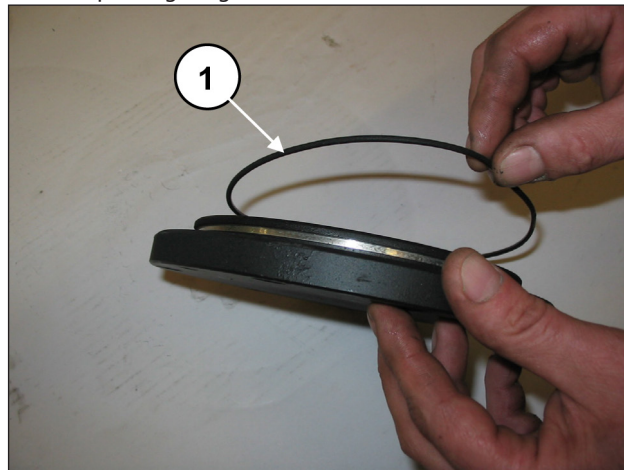

Abb. 91

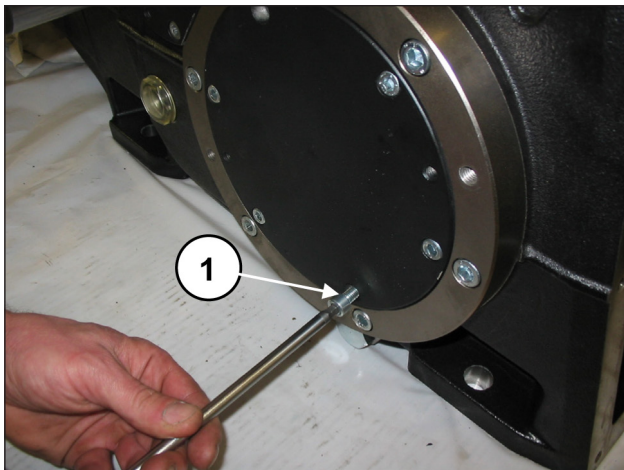

Abb. 92

Montieren Sie den radialen Dichtring in den Ölabbstreifungs-Deckel (Pos. ①, Abb. 93) mithilfe eines Dorns Art. 27910900.

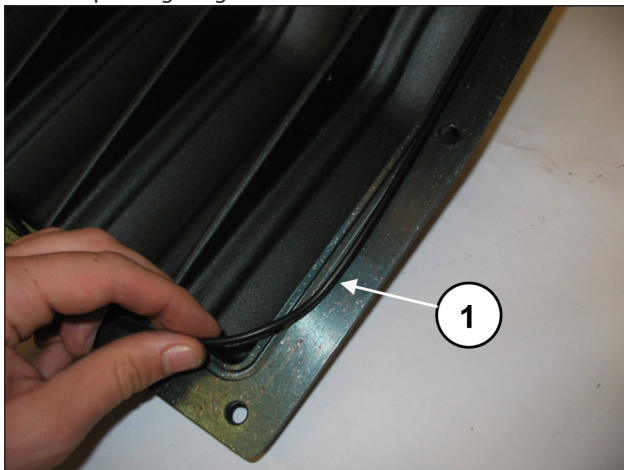

Abb. 93

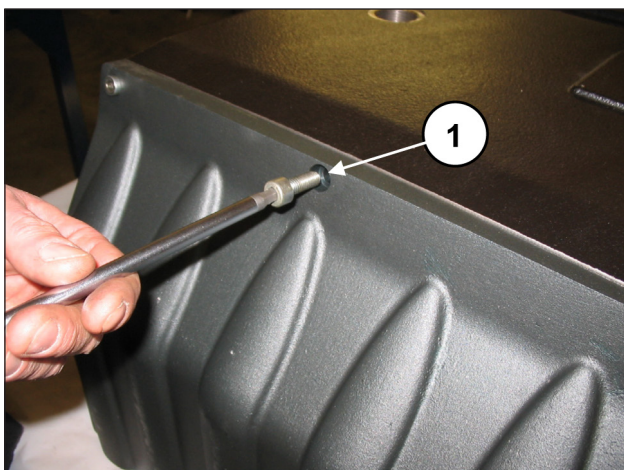
Setzen Sie den O-Ring (Pos. ①, Abb. 94) in den Sitz des Ölabbstreifungs-Deckels ein.

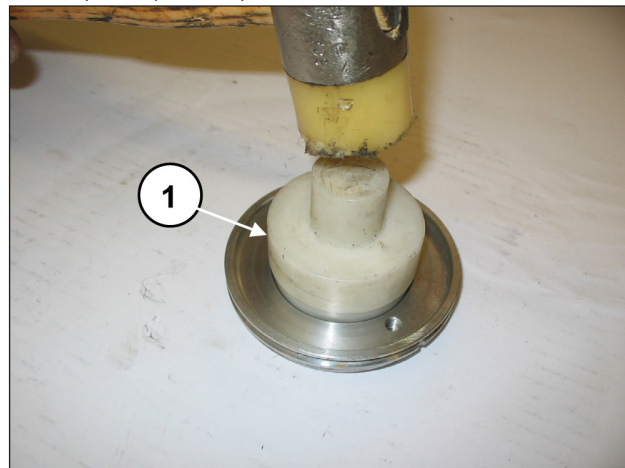

Abb. 94

Bauen Sie die montierte Gruppe im entsprechenden Gehäusesitz ein, überprüfen Sie den passgerechten Sitz des Deckels (Pos. ①, Abb. 95) und achten Sie darauf, nicht die Dichtlippe des radialen Dichtrings zu beschädigen. Befestigen Sie die zwei Ölabbstreifungs-Deckel anhand von 2 Stiftschrauben M6x30 (Pos. ①, Abb. 96).



Abb. 95

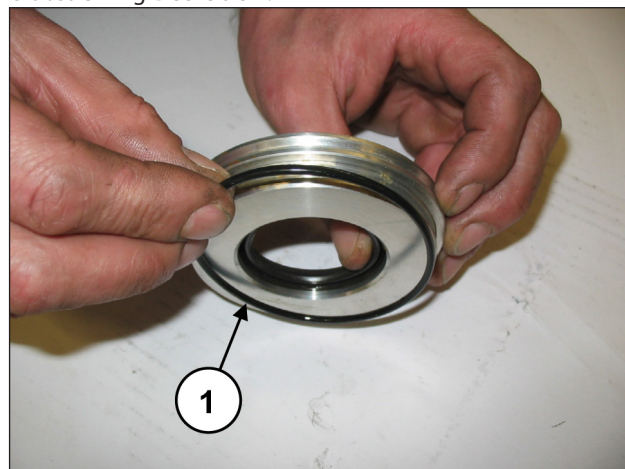

Abb. 96

Eichen Sie die Schrauben mit einem Drehmomentschlüssel, wie in Kapitel 3 gezeigt.
Montieren Sie den Spritzschutz und den Spritzschutz-Distanzring in die Aufnahme an der Kolbenführung (Pos. ①, Abb. 97 und Abb. 98).

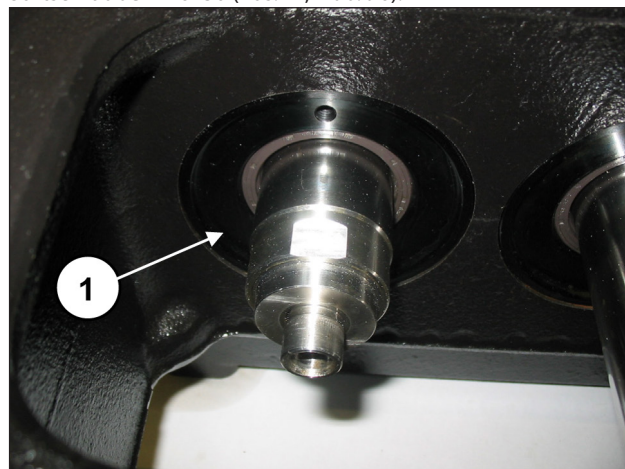

Abb. 97

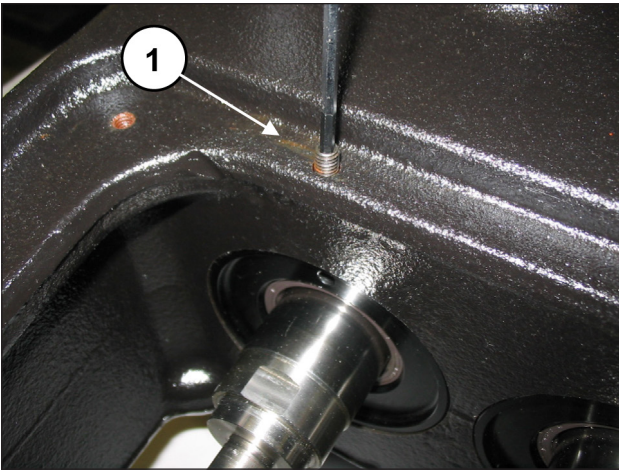

Abb. 98

Setzen Sie auf die beiden Inspektionsdeckel den O-Ring (Pos. ①, Abb. 99) und montieren Sie die Deckel anhand von 4+4 Schrauben M6x14 (Pos. ①, Abb. 100).

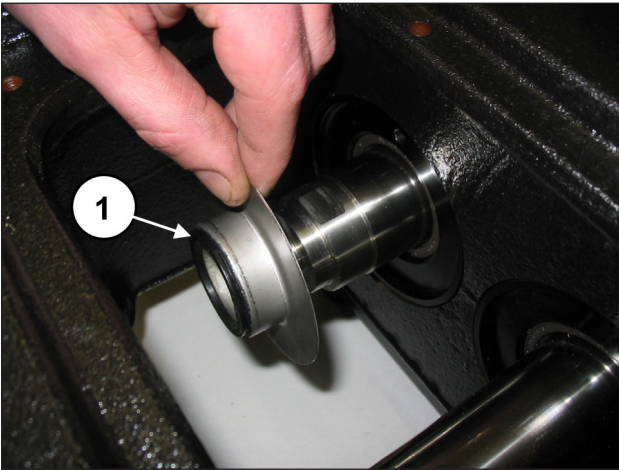

Abb. 99

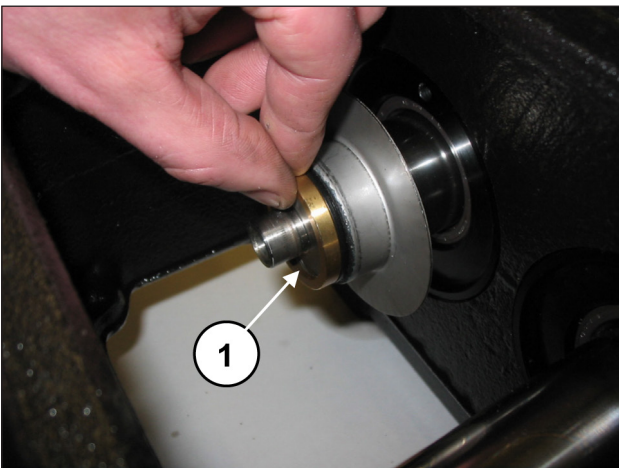

Abb. 100

Eichen Sie die Schrauben mit einem Drehmomentschlüssel, wie in Kapitel 3 Eichwerte für den Schraubenanzug gezeigt.
Montieren Sie den Wellenenddeckel und befestigen Sie den Deckel am Gehäuse anhand von 3 Schrauben M8x20 (Pos. ①, Abb. 101).

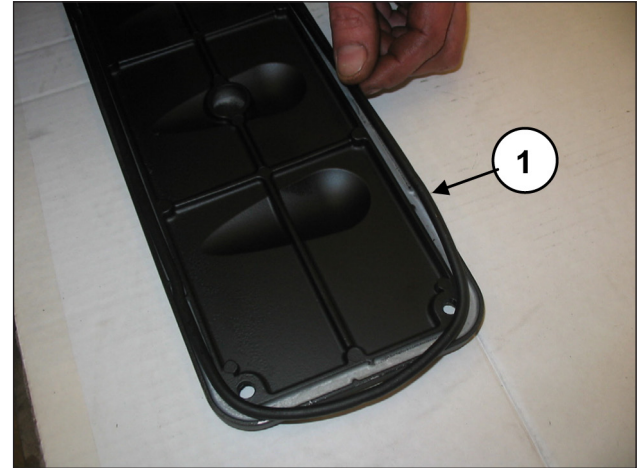
Eichen Sie die Schrauben mit einem Drehmomentschlüssel, wie in Kapitel 3 Eichwerte für den Schraubenanzug gezeigt.

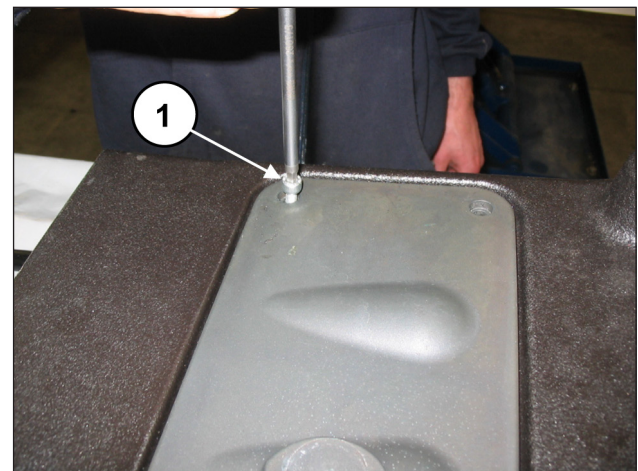

Abb. 101

Setzen Sie die Passfeder auf die Zapfwelle ein (Pos. ①, Abb. 102).



Abb. 102

2.1.3 Vorgesehene Übermaßklassen

ÜBERMASSTABELLE FÜR KURBELWELLE UND PLEUEL-LAGERSCHALEN			
Ausgleichklassen (mm)	Art. obere Lagerschale	Art. untere Lagerschale	Schliff am Durchmesser des Wellenzapfens (mm)
0.25	90931100	90930100	Ø92.75 0/-0.03 Ra 0.4 Rt 3.5
0.50	90931200	90930200	Ø92.50 0/-0.03 Ra 0.4 Rt 3.5

ÜBERMASSTABELLE FÜR PUMPENGEHÄUSE UND KOLBENFÜHRUNG		
Ausgleichklassen (mm)	Artikel Kolbenführung	Schliff am Sitz des Pumpengehäuses (mm)
1.00	79050543	Ø81 H6 +0.022/0 Ra 0.8 Rt 6

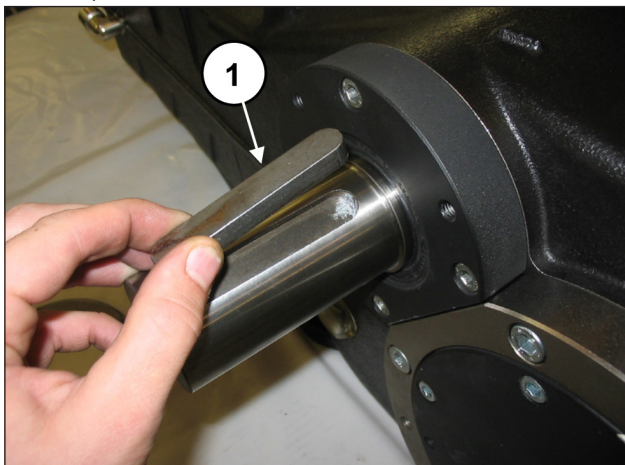
2.2 REPARATUR DER HYDRAULIK

2.2.1 Ausbau des Kopfs - Ventilgruppen

Der Kopf bedarf einer vorbeugenden Wartung lt. Angaben in der **Betriebs- und Wartungsanleitung**.

Die Arbeiten beschränken sich auf die Inspektion oder den Austausch der Ventile im Bedarfsfall.

Verfahren Sie zur Abnahme der Ventilgruppen wie folgt:
Drehen Sie den Ventilöffner mit einem 30 mm Schlüssel ab (Pos. ①, Abb. 103).



Abb. 103

Bringen Sie zwei Halter mit Gewinde G2" an die Druckanschlüsse des Kopfs an (Pos. ①, Abb. 104) und lösen Sie dann die 8 Schrauben M16x150 (Pos. ①, Abb. 105). Achten Sie beim Ausziehen des Kopfs darauf, nicht gegen die Kolben zu stoßen.



Abb. 104

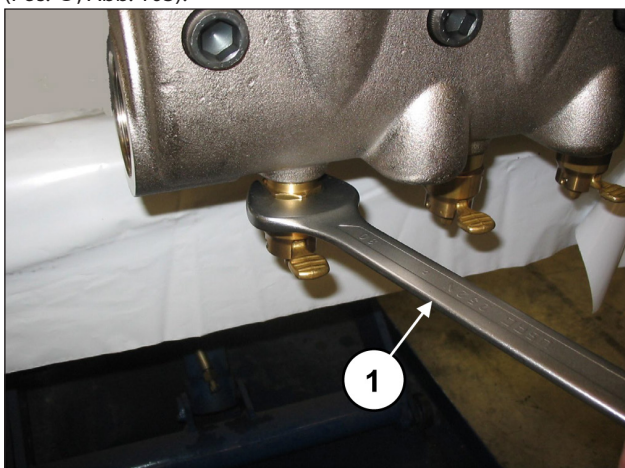

Abb. 105

Entfernen Sie die 8 Schrauben M16x55 des Ventildeckels (Pos. ①, Abb. 106) und nehmen Sie den Deckel ab (Pos. ①, Abb. 107).

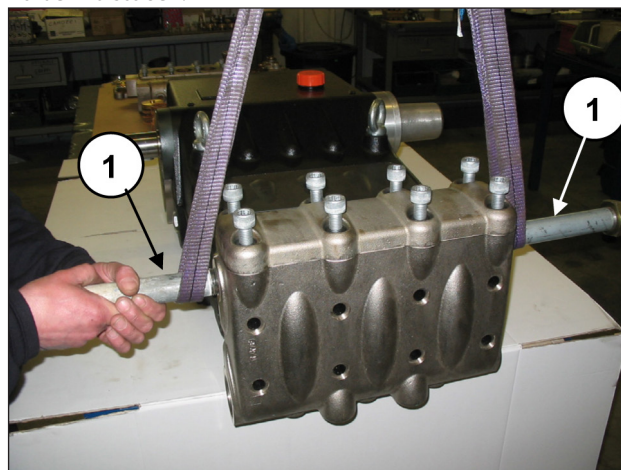

Abb. 106

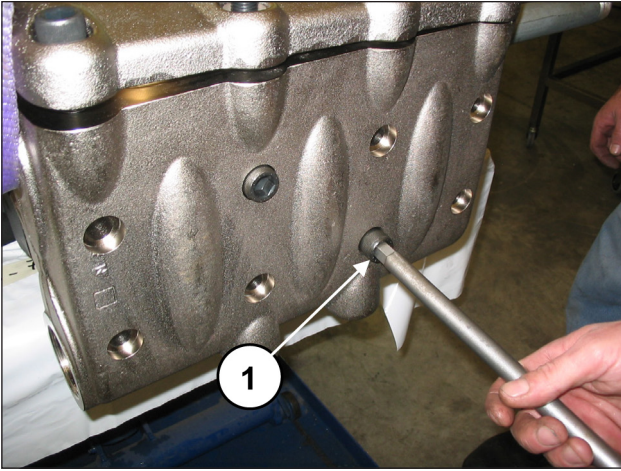

Abb. 107

Entfernen Sie die Ventilkappe mithilfe eines Abziehers mit Schlagwerk an der Bohrung M10 der Ventilkappe (Pos. ①, Abb. 108).

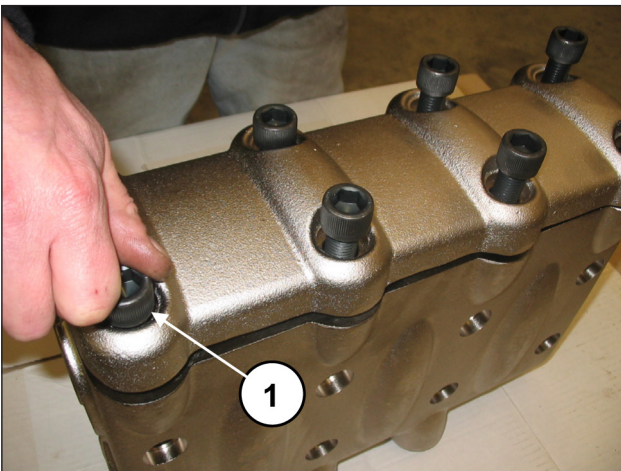

Abb. 108

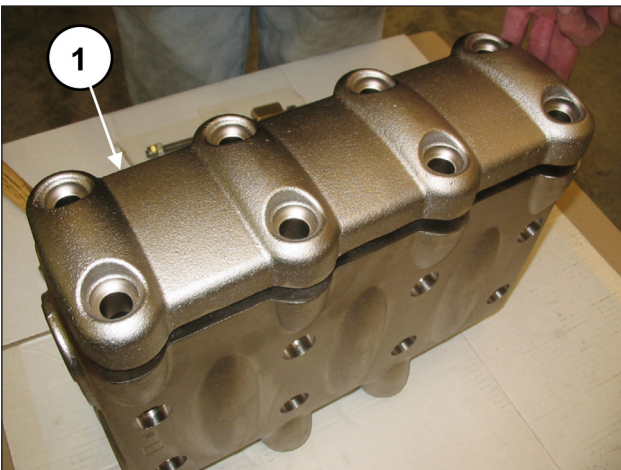
Entfernen Sie die Feder (Pos. ①, Abb. 109).

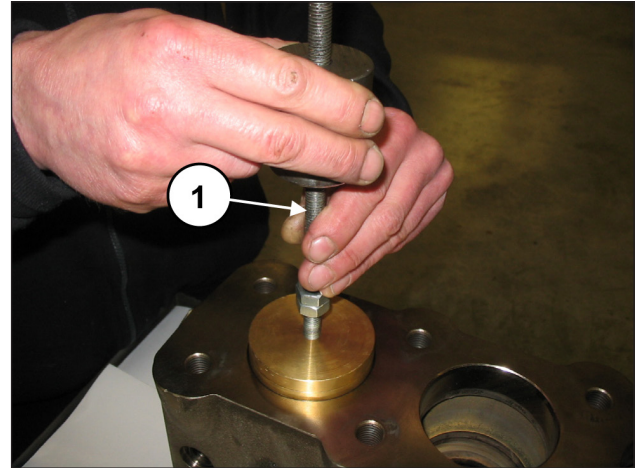

Abb. 109

Entfernen Sie die Druckventilgruppe mithilfe eines Abziehers mit Schlagwerk an der Bohrung M10 der Ventilführung (Pos. ①, Abb. 110).



Abb. 110

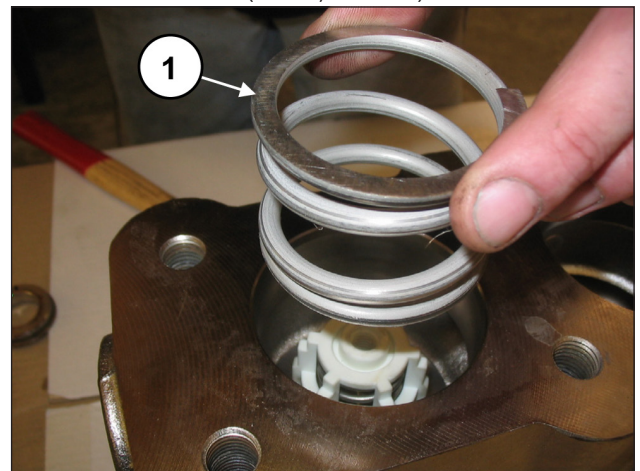

Sollte der Ausbau der Druckventilgruppe mit großen Schwierigkeiten verbunden sein (z. B. aufgrund von Verkrustungen nach längerem Stillstand der Pumpe), verwenden Sie den Abzieher Art. 27516400.

Ziehen Sie das Distanzstück der Ventilführung durch einen 8 mm Sechskantschlüssel heraus (Pos. ①, Abb. 111).

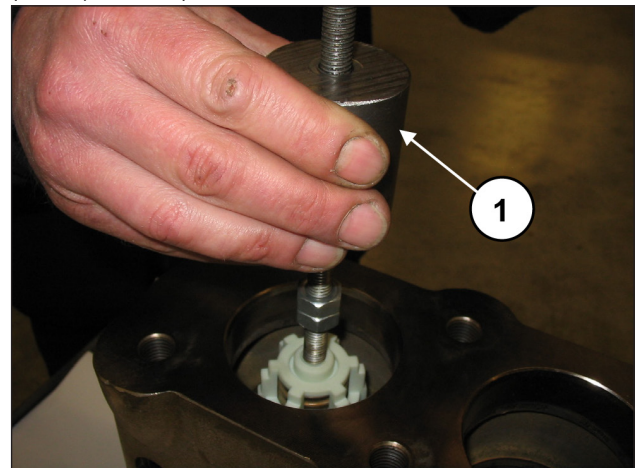

Abb. 111

Entfernen Sie die Druckventilgruppe mithilfe eines Abziehers mit Schlagwerk an der Bohrung M10 der Ventilführung (Pos. ①, Abb. 112).



Abb. 112

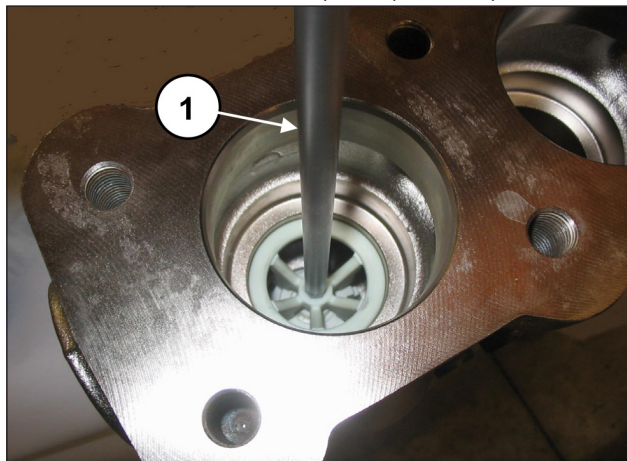

Sollte der Ausbau der Saugventilgruppe mit großen Schwierigkeiten verbunden sein (z. B. aufgrund von Verkrustungen nach längerem Stillstand der Pumpe), verwenden Sie den Abzieher Art. 27516200 (für LK36-LK40-LK45) oder Art. 27516300 (für LK50-LK55-LK60) (Pos. ①, Abb. 113) und gehen Sie lt. Anweisungen vor.

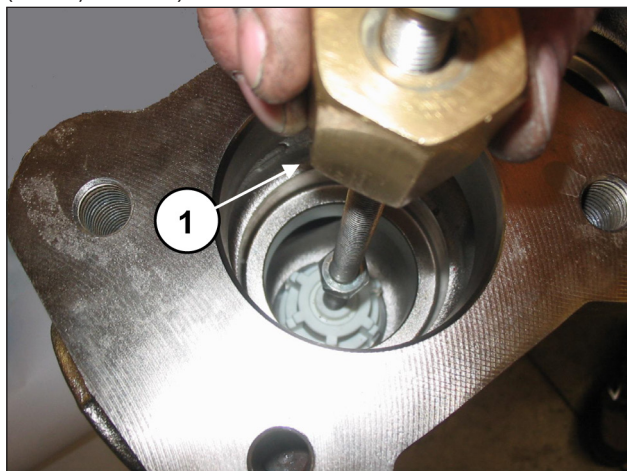

Abb. 113

Bauen Sie die Saug- und Druckventilgruppen durch Anziehen einer Schraube M10 aus, um durch Drücken auf die innere Führung die Ventilführung aus dem Ventilsitz herausziehen zu können (Pos. ①, Abb. 114).

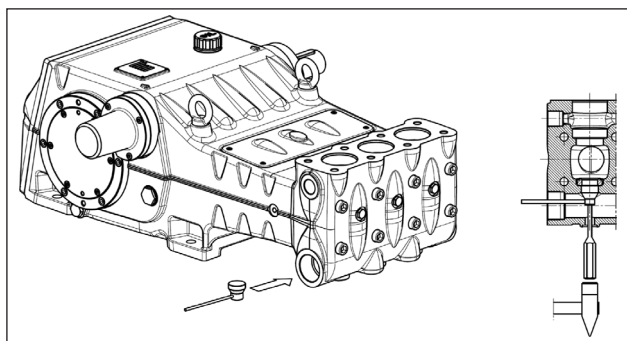

Abb. 114

2.2.2 Einbau des Kopfs - Ventilgruppen

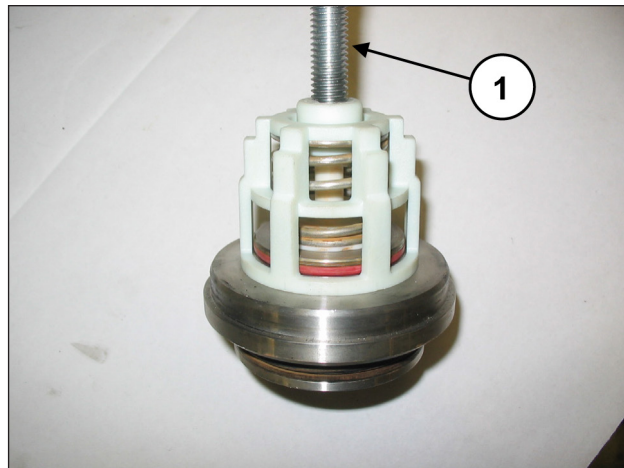

Achten Sie besonders auf den Verschleißzustand der einzelnen Bauteile und tauschen Sie diese bei Bedarf aus.

Ersetzen Sie bei jeder Inspektion der Ventile alle O-Ringe sowohl der Ventilgruppen als auch der Ventilkappen.



Vor dem Wiedereinbau der Ventilgruppen reinigen und trocknen Sie gründlich ihre Sitze im Kopf, siehe Pfeile (Pos. ①, Abb. 115).



Abb. 115

Verfahren Sie für den Wiedereinbau in umgekehrter Ausbaureihenfolge zu den Angaben in Abschn. 2.2.1.

Achten Sie beim Einbau der Saug- und Druckventilgruppen (Abb. 116 und Abb. 117) darauf, nicht die vorab abgenommenen Federn zu vertauschen. Um das Einsetzen der Ventilführung in den Sitz zu erleichtern, verwenden Sie ein Rohr, das auf den horizontalen Flächen der Führung aufliegt (Abb. 118) und benutzen Sie ein Schlagwerk am gesamten Umfang.

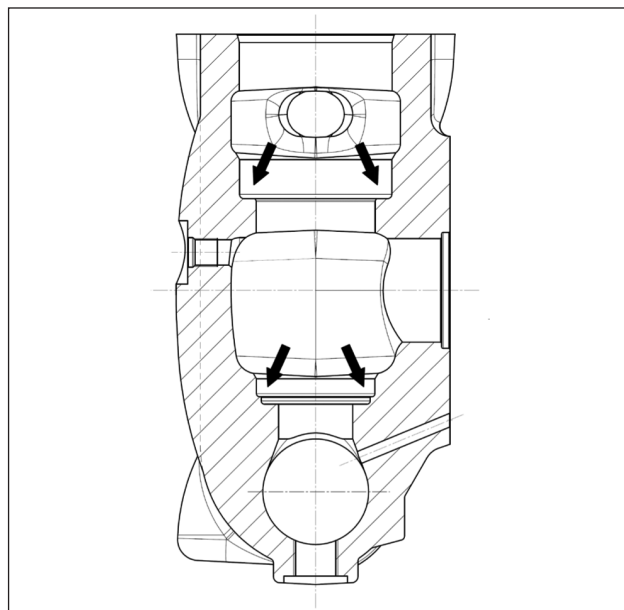

Abb. 116



Abb. 117



Abb. 118

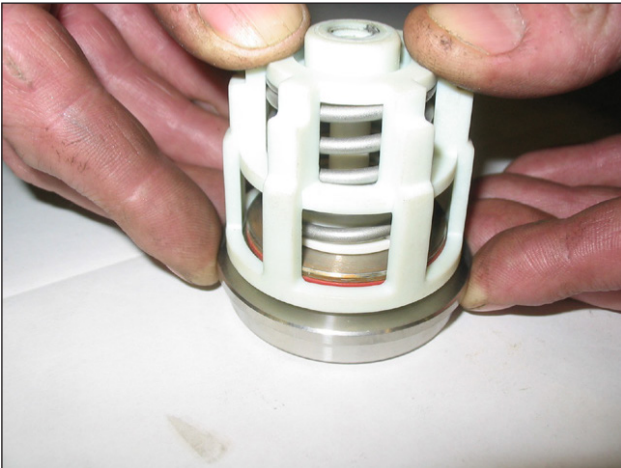

Achten Sie beim Einsetzen der Ventilgruppen (Saug- und Druckseite) in den Kopf auf die korrekte Einbaureihenfolge der O-Ringe und der Stützringe.

Die vorschriftsmäßige Einbaureihenfolge der Ventilgruppen in den Kopf lautet:

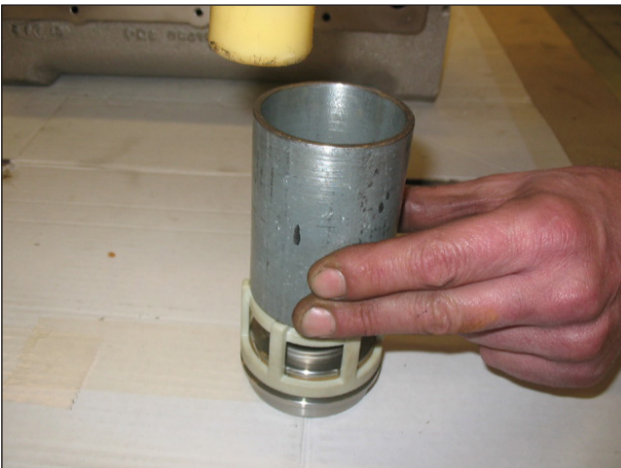
Setzen Sie den Stützring ein, Pos. 4 Explosionszeichnung (Pos. ①, Abb. 119).



Abb. 119

Setzen Sie den O-Ring ein, Pos. 5 Explosionszeichnung (Pos. ①, Abb. 120).

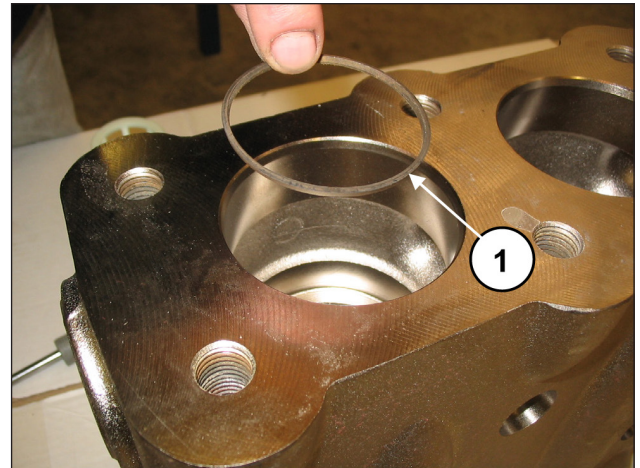

Abb. 120

Vergewissern Sie sich, dass O- und Stützring bündig im Sitz montiert sind.

Setzen Sie die Saugventilgruppe ein (Pos. ①, Abb. 121) und anschließend das Distanzstück (Pos. ①, Abb. 122).

Die komplette Ventilgruppe muss bündig eingesetzt sein und so erscheinen wie in Pos. ①, Abb. 122.

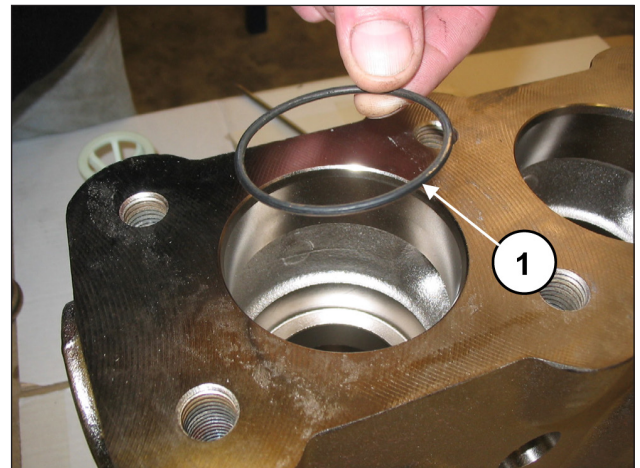

Abb. 121



Abb. 122

Montieren Sie den O-Ring, Pos. 5 Explosionszeichnung (Pos. ①, Abb. 123) und den Stützring, Pos. 15 Explosionszeichnung (Pos. ②, Abb. 123) auf den Sitz des Druckventils.

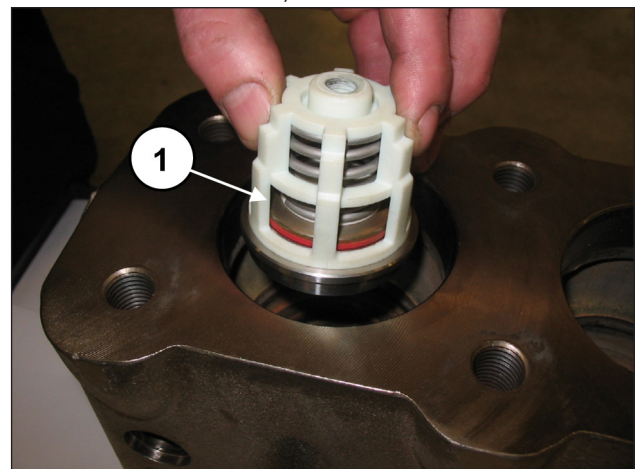

Abb. 123

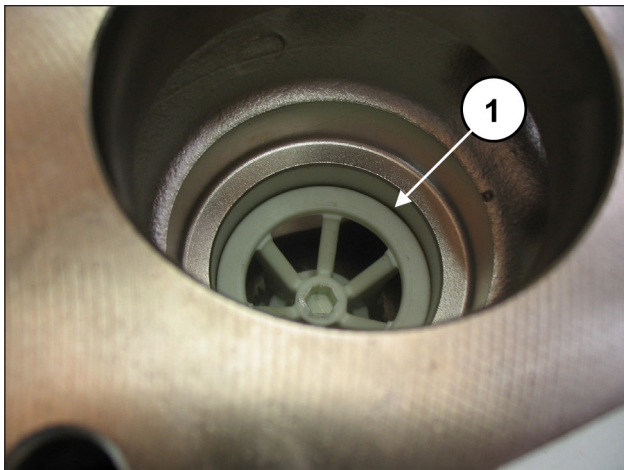
Setzen Sie die Druckventilgruppe ein (Pos. ①, Abb. 124). Die Ventilgruppe muss bündig eingesetzt sein und so erscheinen wie in Pos. ①, Abb. 125.



Abb. 124

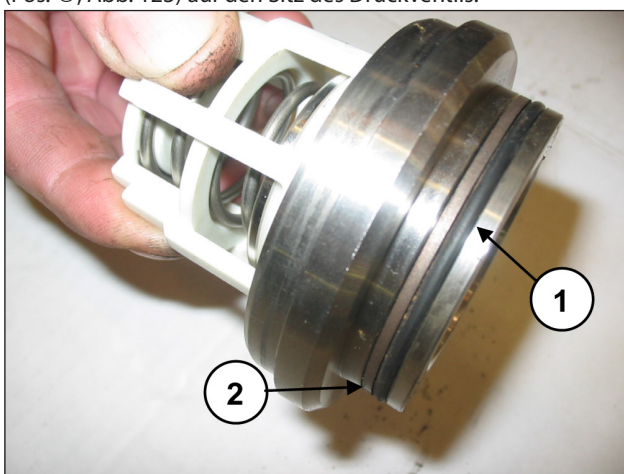

Abb. 125

Setzen Sie den Stützring ein, Pos. 16 Explosionszeichnung (Pos. ①, Abb. 126).

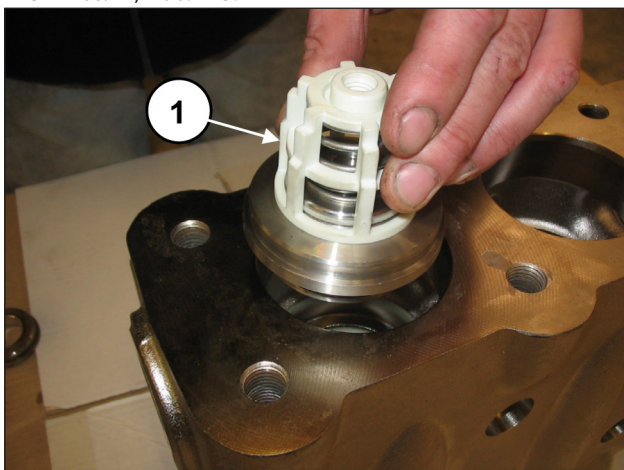

Abb. 126

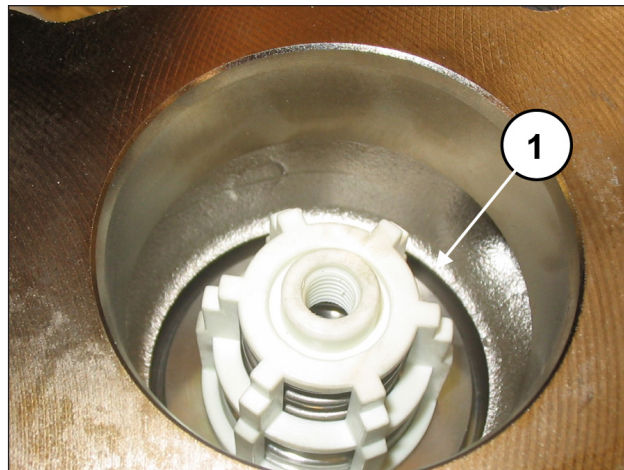
Setzen Sie den O-Ring ein, Pos. 17 Explosionszeichnung (Pos. ①, Abb. 127).



Abb. 127

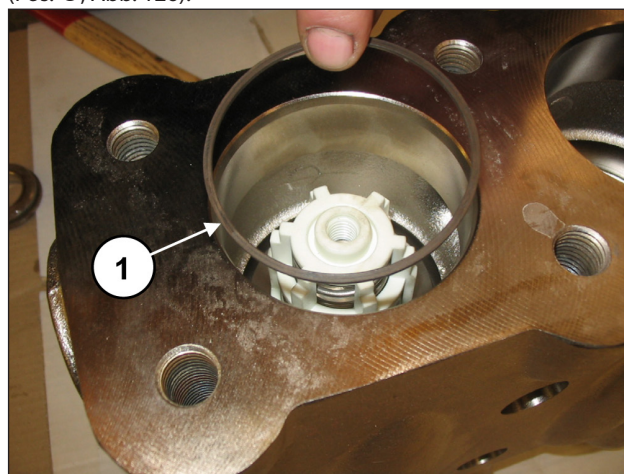

Achten Sie besonders auf das Einsetzen des O-Rings Pos. ①, Abb. 128.

Verwenden Sie das Werkzeug Art. 27516000 (für LK36-LK40-LK45) oder Art. 27516100 (für LK50-LK55-LK60), damit der O-Ring beim Einsetzen nicht reißt.

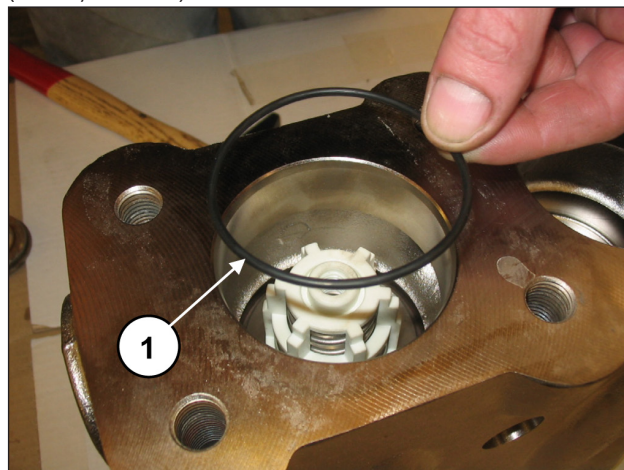

Abb. 128

Setzen Sie den Ring des Ventilsitzes (Pos. ①, Abb. 129) und die Feder ein (Pos. ①, Abb. 130).



Abb. 129

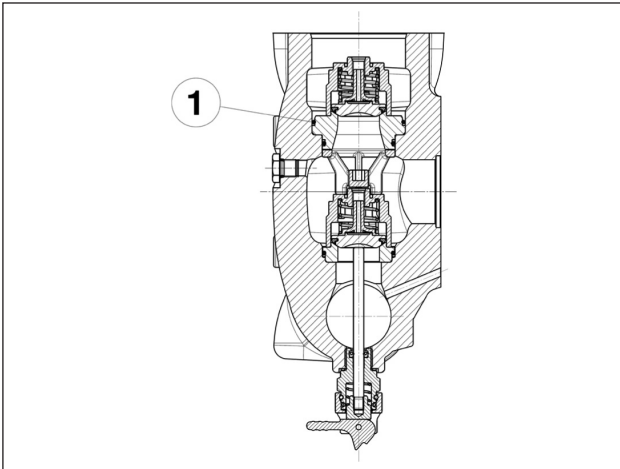

Abb. 130

Montieren Sie den O-Ring, Pos. 17 Explosionszeichnung (Pos. ①, Abb. 131) und den Stützring, Pos. 21 Explosionszeichnung (Pos. ②, Abb. 131) auf die Druckventilkappe.

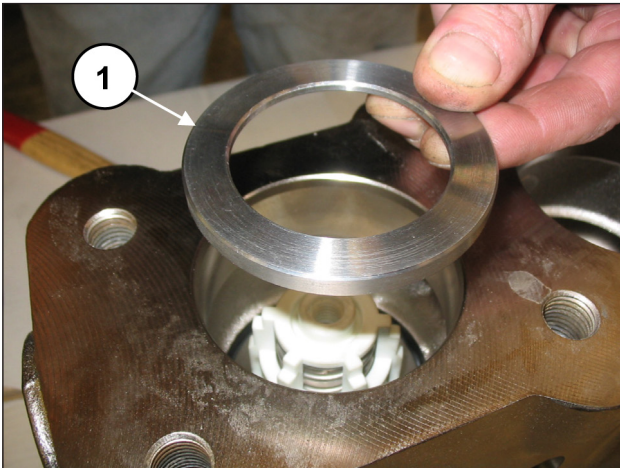

Abb. 131

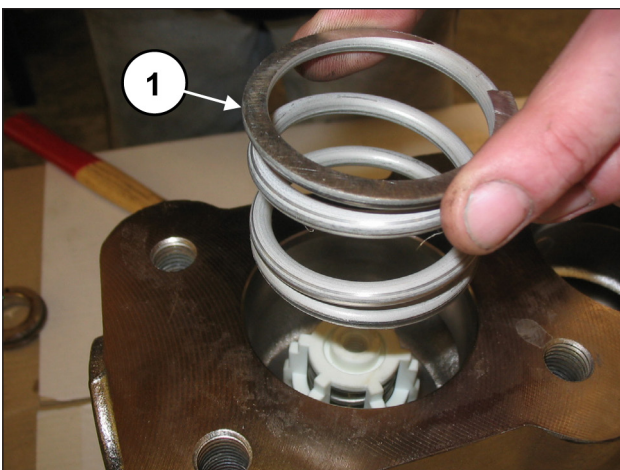
Setzen Sie die Ventilkappe samt O-Ring und Stützring ein. Bringen Sie nach Montage der Ventilgruppen und Ventilkappen den Ventildeckel an (Pos. ①, Abb. 132) und ziehen Sie die 8 Schrauben M16x55 fest (Pos. ①, Abb. 133).



Abb. 132

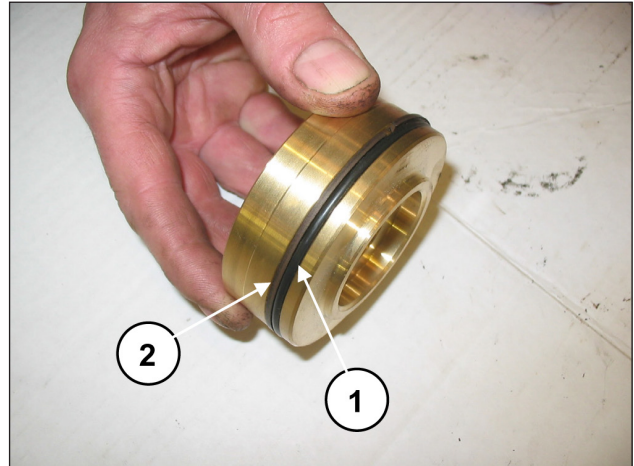

Abb. 133

Bauen Sie den Kopf auf das Pumpengehäuse an (Pos. ①, Abb. 134) und achten Sie dabei, nicht gegen die Kolben zu stoßen. Ziehen Sie dann die 8 Schrauben M16x150 fest (Pos. ①, Abb. 135).

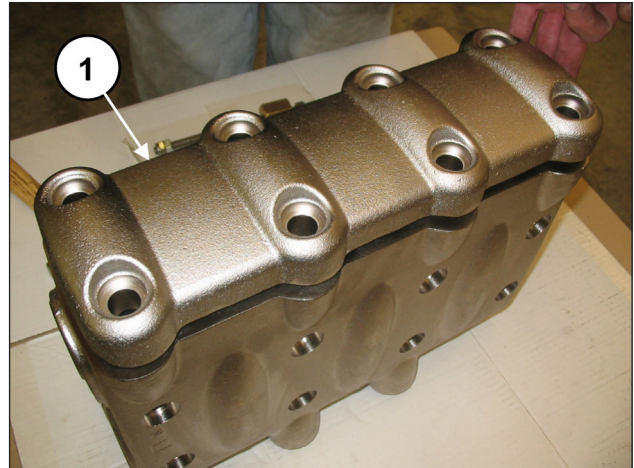

Abb. 134

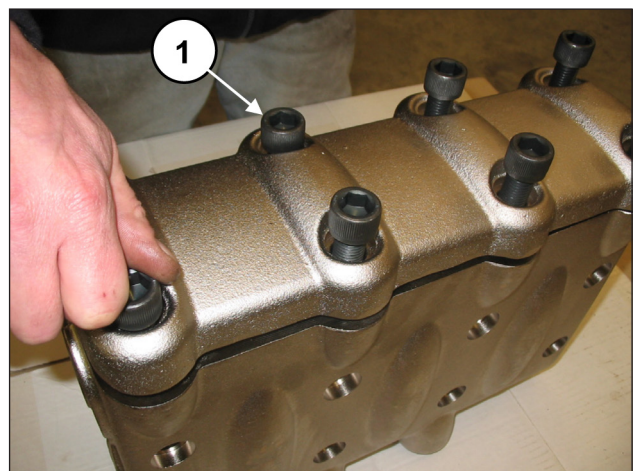

Abb. 135

Eichen Sie die Schrauben M16x150 mit einem Drehmomentschlüssel, wie in Kapitel 3 "Eichwerte für den Schraubenanzug" gezeigt.

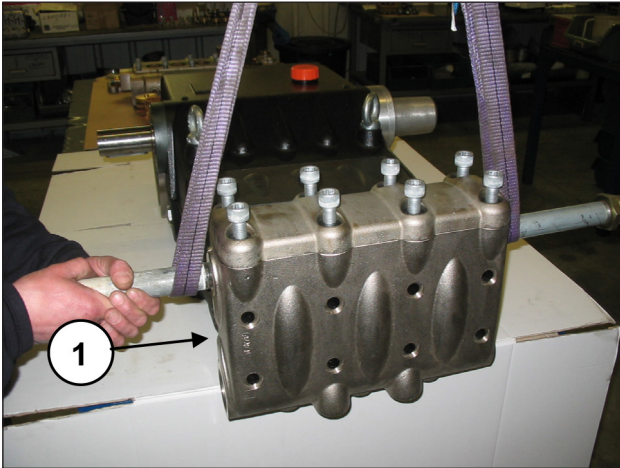

Ziehen Sie die 8 Schrauben M16x150 von den 4 Innenschrauben ausgehend über Kreuz an (siehe Abb. 135), setzen Sie den Anzug dann mit den 4 Außenschrauben ebenfalls über Kreuz fort

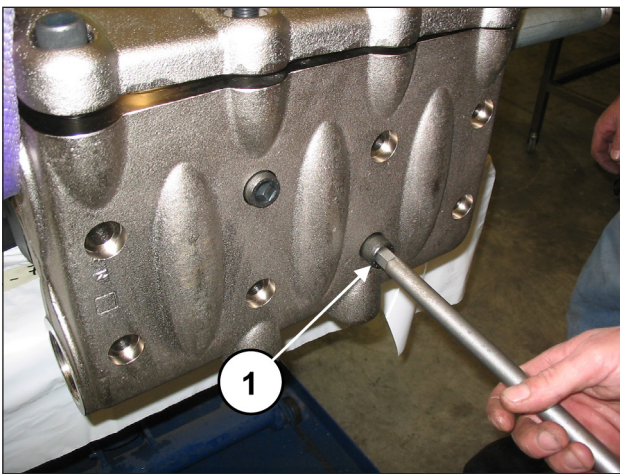
Eichen Sie die Schrauben M16x55 des Deckels mit einem Drehmomentschlüssel, wie in Kapitel 3 Eichwerte für den Schraubenanzug gezeigt.

Bringen Sie die Ventilöffner an (Pos. ①, Abb. 136) und drehen Sie diese mit einem 30 mm Schlüssel fest (Pos. ①, Abb. 137).



Abb. 136



Abb. 137

2.2.3 Ausbau der Kolbengruppe - Lager - Dichtungen

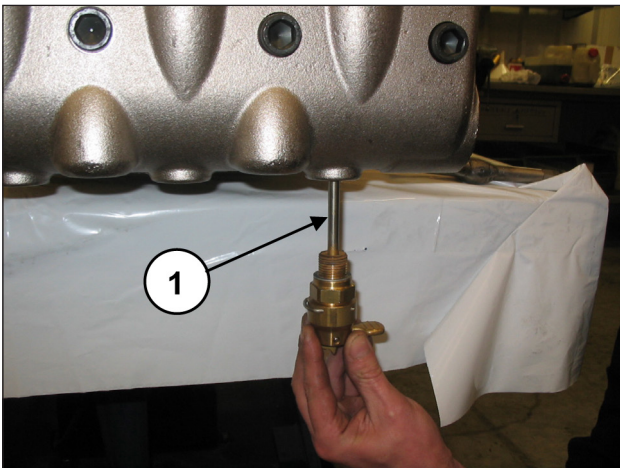
Die Kolbengruppe bedarf einer regelmäßigen Prüfung lt. Angaben in der Tabelle der vorbeugenden Wartung der **Betriebs- und Wartungsanleitung**. Die Eingriffe beschränken sich lediglich auf die Sichtprüfung der Ablassbohrung am unteren Deckel. Sollten Störungen / Schwingungen am Druckmanometer oder Tropferscheinungen aus der Ablassbohrung auftreten, muss das Dichtungspaket überprüft und ggf. ausgetauscht werden. Verfahren Sie zur Abnahme der Kolbenbaugruppen wie folgt: Lösen Sie für den Zugriff auf die Kolbengruppe die Schrauben M16x150 und bauen Sie den Kopf aus.

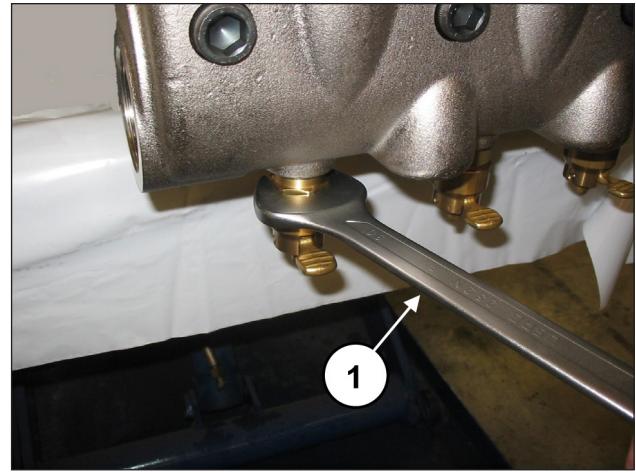

Ziehen Sie den Kopf mit größter Vorsicht heraus, um nicht gegen die Kolben zu stoßen.

Demontieren Sie die Kolben durch Abdrehen der Befestigungsschrauben (Pos. ①, Abb. 138).

Streifen Sie den Kolben aus dem Dichtungshalter und überprüfen Sie die Kolbenoberfläche auf etwaige Kratzer, Verschleiß- oder Kavitationsanzeichen



Abb. 138

Demontieren Sie den oberen Inspektionsdeckel (Pos. ①, Abb. 139) und den unteren Inspektionsdeckel (Pos. ①, Abb. 140) durch Abdrehen der 4+4 Befestigungsschrauben.



Abb. 139

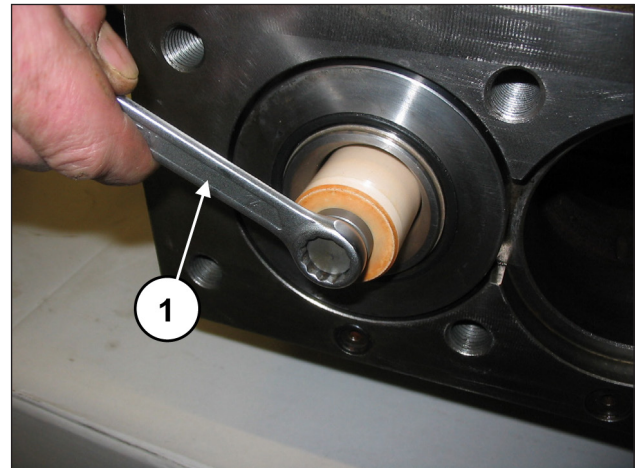

Abb. 140

Drehen Sie die Welle von Hand so, dass die 3 Kolben an ihren oberen Totpunkt bewegt werden. Setzen Sie den Dorn Art. 27516600 zwischen Kolbenführung und Kolben ein (Pos. ①, Abb. 141).

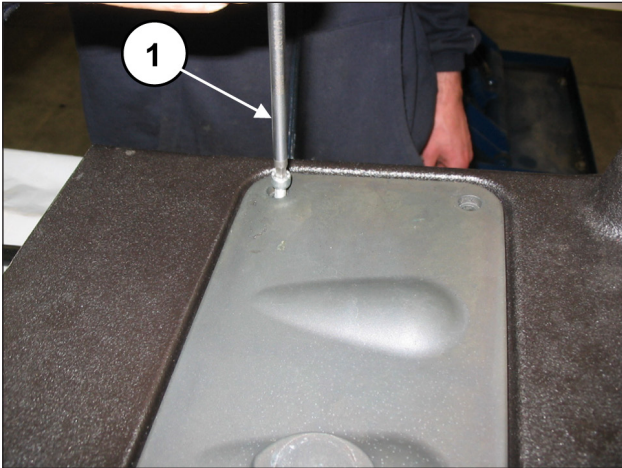

Abb. 141

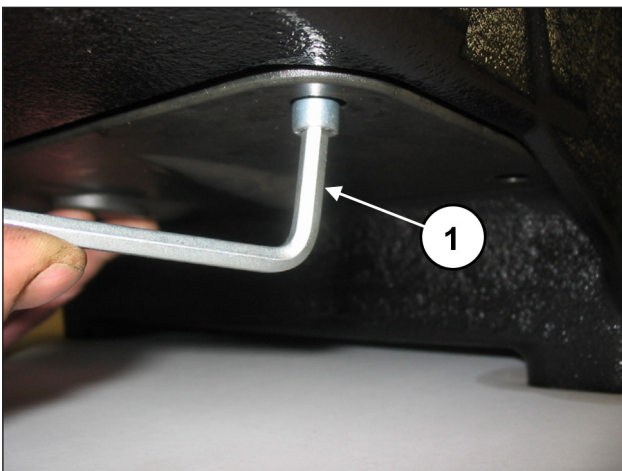
Schieben Sie die Kolbenführung durch Drehen der Welle soweit vor, dass der mitgetriebene Dorn den Dichtungshalter und die gesamte Kolbenbaugruppe herausdrückt (Pos. ①, Abb. 142).

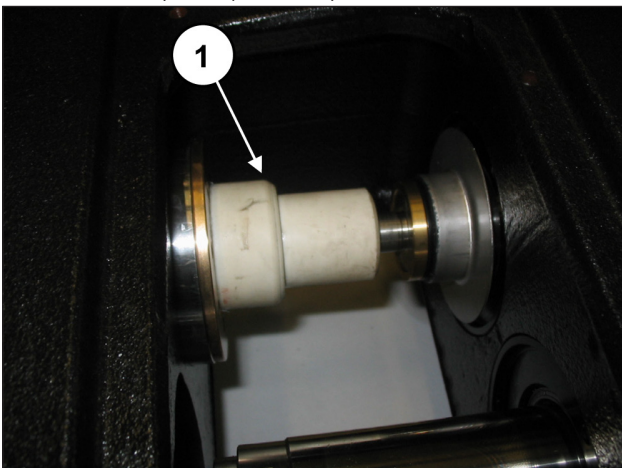

Abb. 142

Entfernen Sie den Dichtungshalter und den Dorn. Entfernen Sie die Spritzschutz-Distanzringe von den Kolbenführungen (Pos. ①, Abb. 143) und die Spritzschutzringe (Pos. ①, Abb. 144).



Abb. 143

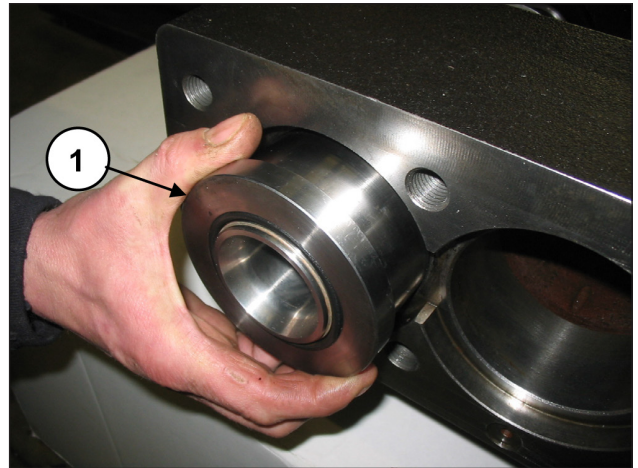

Abb. 144

Trennen Sie den Dichtungshalter von der Buchse mithilfe eines marktgängigen Hakenschlüssels mit runden Nasen $\varnothing 5$ (Pos. ①, Abb. 145) und drehen Sie den Halter vollkommen ab (Pos. ①, Abb. 146).

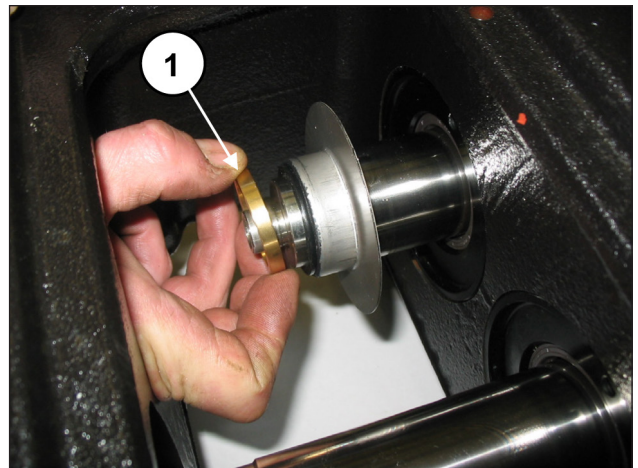

Abb. 145



Abb. 146

Entnehmen Sie die Kopfringe, die Druckdichtungen und die Restop-Ringe von Hand (Pos. ①, Abb. 147).

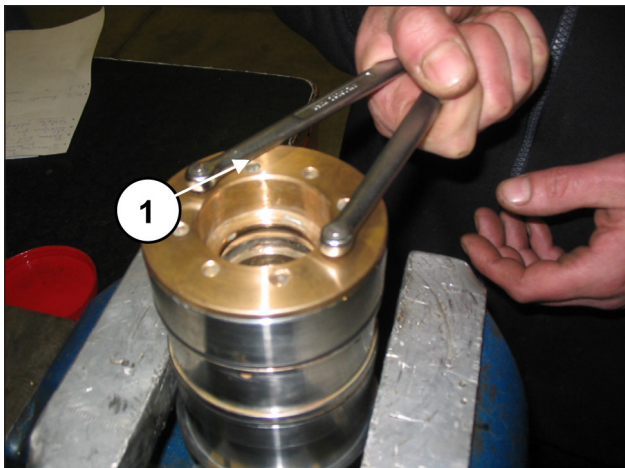

Abb. 147

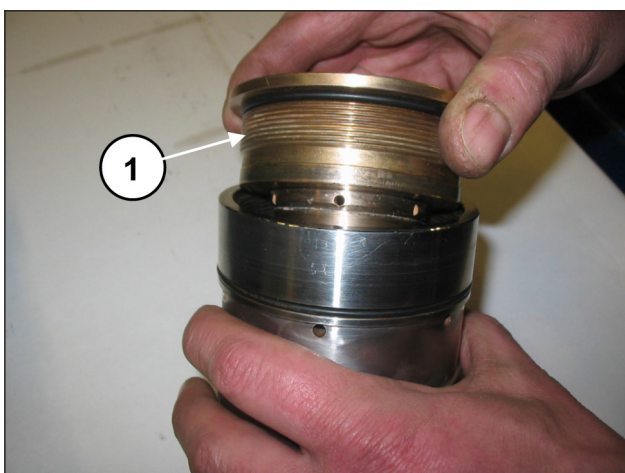
Zur Abnahme der ND-Dichtung müssen Sie eine Fühlerlehre oder ein ähnliches Werkzeug verwenden, das den Sitz des Dichtungshalters nicht beschädigt (Pos. ①, Abb. 148).



Abb. 148

2.2.4 Einbau der Kolbengruppe - Lager - Dichtungen

Verfahren Sie für den Wiedereinbau in umgekehrter Ausbaureihenfolge zu den Angaben in Abschn. 2.2.3.

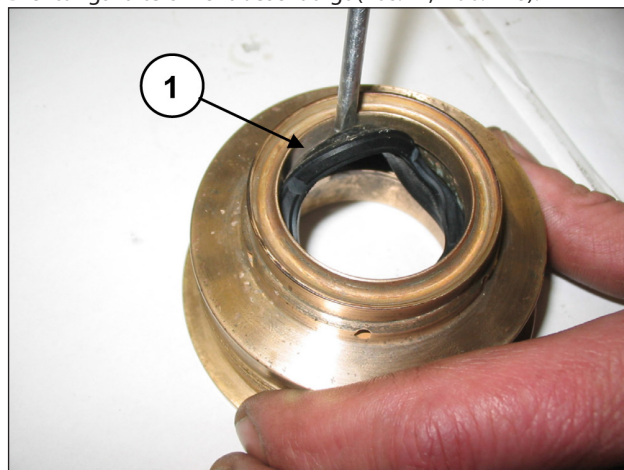

Ersetzen Sie die Druckdichtungen, indem Sie die Dichtlippen mit Silikonfett befeuchten (nicht bestreichen). Achten Sie besonders darauf, die Dichtungen beim Einsetzen in die Buchse nicht zu beschädigen.



Bei jedem Ausbau müssen die Druckdichtungen mit sämtlichen O-Ringen ersetzt werden.

Setzen Sie die ND-Dichtung in den Dichtungshalter ein (Pos. ①, Abb. 149) und achten Sie hierbei auf die Einbaurichtung mit nach vorn gerichteter Dichtlippe (zum Kopf hin).



Abb. 149

Montieren Sie den Kopfring (Pos. ①, Abb. 150), die HD-Dichtung (Pos. ①, Abb. 151) und den Restop-Ring (Pos. ①, Abb. 152).



Abb. 150

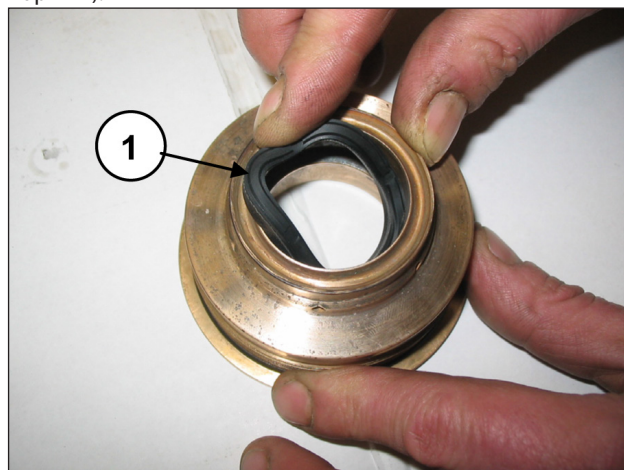

Abb. 151

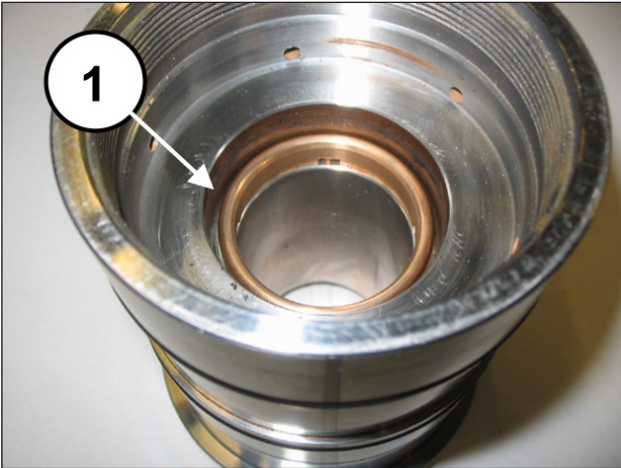

Abb. 152

Setzen Sie den O-Ring des Dichtungshalters in seinen Sitz ein (Pos. ①, Abb. 153).

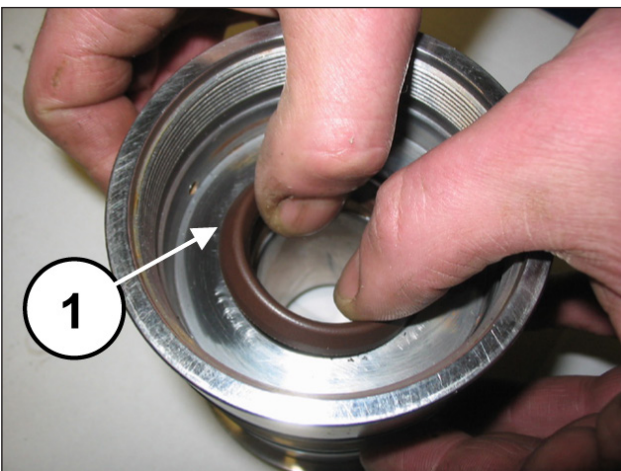

Abb. 153

Schrauben Sie den Dichtungshalter auf die Buchse (Pos. ①, Abb. 154) und ziehen Sie mithilfe eines marktgängigen Hakenschlüssels mit runden Nasen $\varnothing 5$ soweit fest, (Pos. ①, Abb. 155) bis der Halter bündig auf der Buchse aufliegt.



Abb. 154

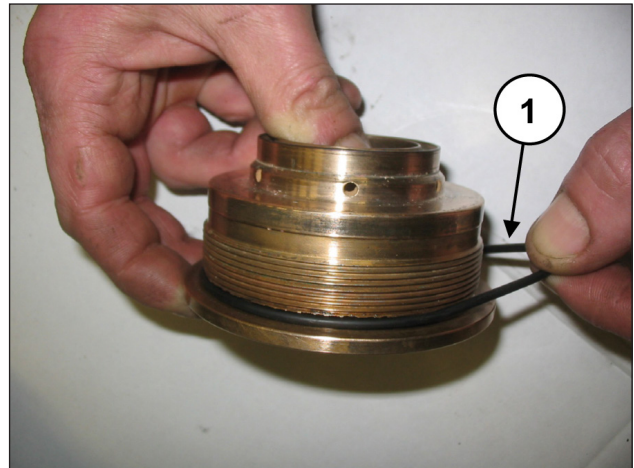

Abb. 155

Setzen Sie die Unterlegscheibe $\varnothing 10 \times 18 \times 0,9$ auf die Befestigungsschraube des Kolbens (Pos. ①, Abb. 156).

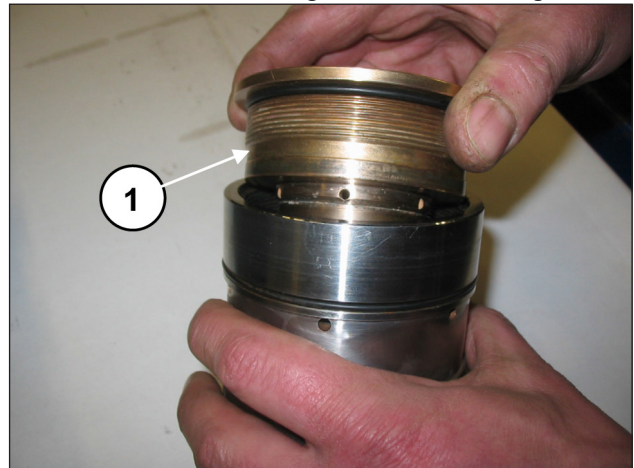

Abb. 156

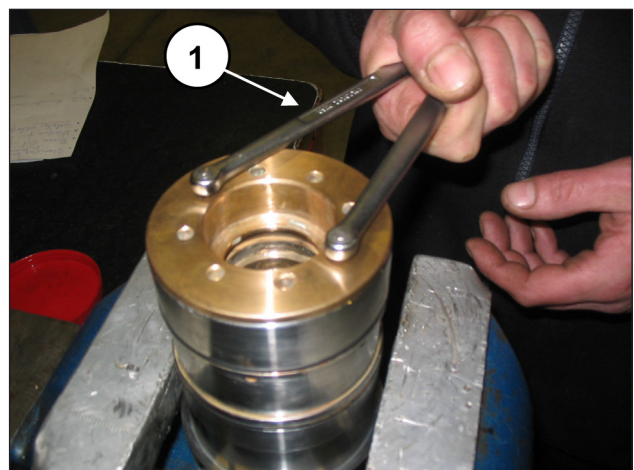
Montieren Sie die Kolben in die entsprechenden Führungen (Pos. ①, Abb. 157) und befestigen Sie diese lt. Pos. ①, Abb. 158.



Abb. 157

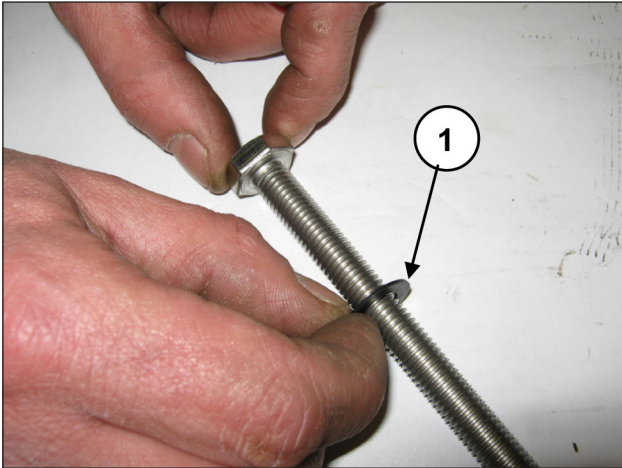

Abb. 158

Eichen Sie die Schrauben mit einem Drehmomentschlüssel, wie in Kapitel 3 gezeigt.

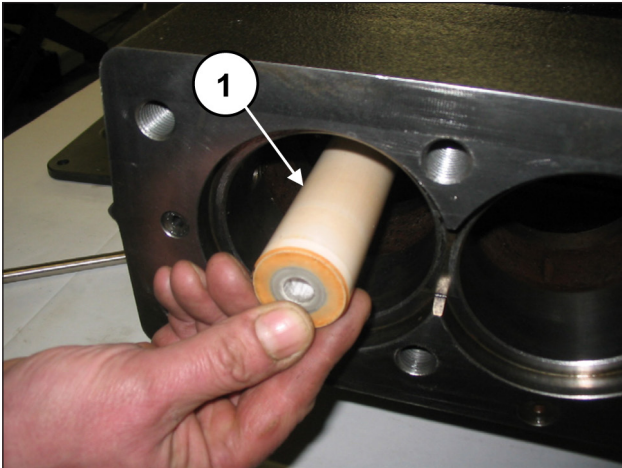
Montieren Sie die vorab zusammengebaute Gruppe Buchse-Dichtungshalter (mitsamt der beiden O-Ringe) bis auf Anschlag (Pos. ①, Abb. 159).

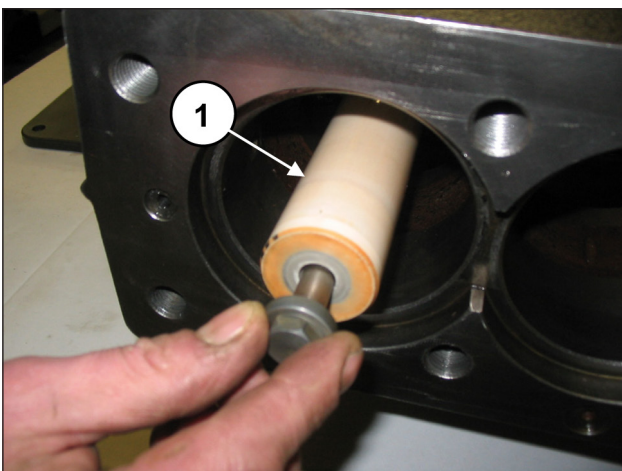

Abb. 159

Vergewissern Sie sich, dass die Gruppe Buchse-Dichtungshalter bündig in ihrem Sitz liegt (Pos. ①, Abb. 160).

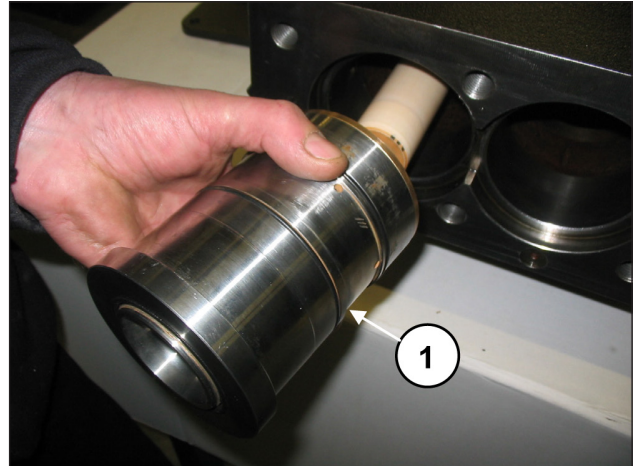

Abb. 160

Setzen Sie den frontseitigen O-Ring der Buchse ein (Pos. ①, Abb. 161) und den O-Ring an der Umlaufbohrung (Pos. ①, Abb. 162).



Abb. 161

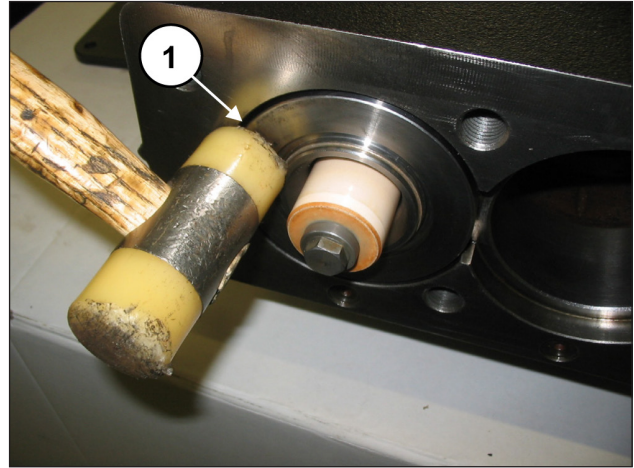

Abb. 162

Setzen Sie auf die Inspektionsdeckel den O-Ring (Pos. ①, Abb. 163) und montieren Sie die Deckel anhand von 4+4 Schrauben M6x14 (Pos. ①, Abb. 164).

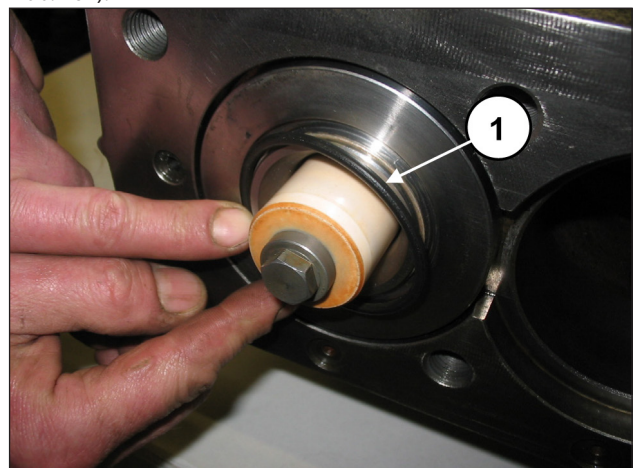

Abb. 163

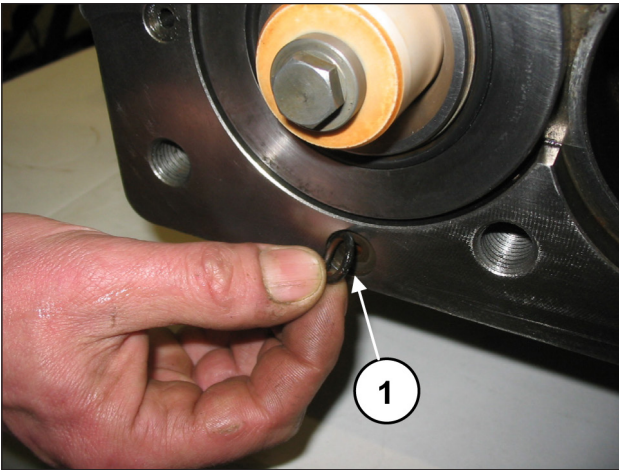

Abb. 164

Eichen Sie die Schrauben mit einem Drehmomentschlüssel, wie in Kapitel 3 gezeigt.

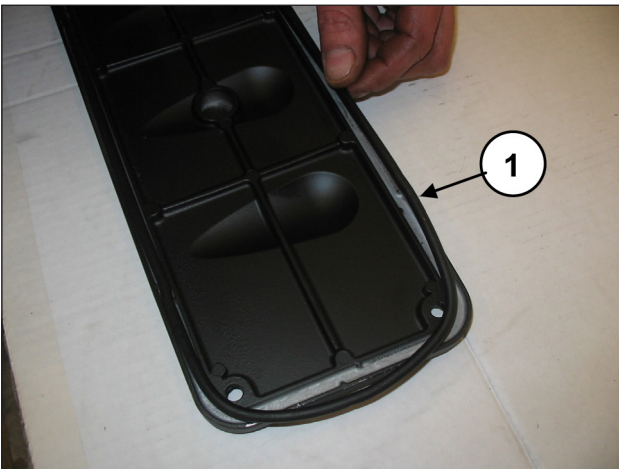
2.2.5 Wiederherstellung des Kopfs

Sollte der Kopf in den Kolbenkammern deutliche Kavitationsanzeichen infolge einer nicht korrekten Pumpenversorgung aufweisen, kann der beschädigte Kopf ohne Bedarf eines Austausch wiederhergestellt werden. Führen Sie zur Wiederherstellung des Kopfs die Bearbeitungen lt. Abb. 165 für LK36-40-45 und lt. Abb. 166 für LK50-55-60 aus:

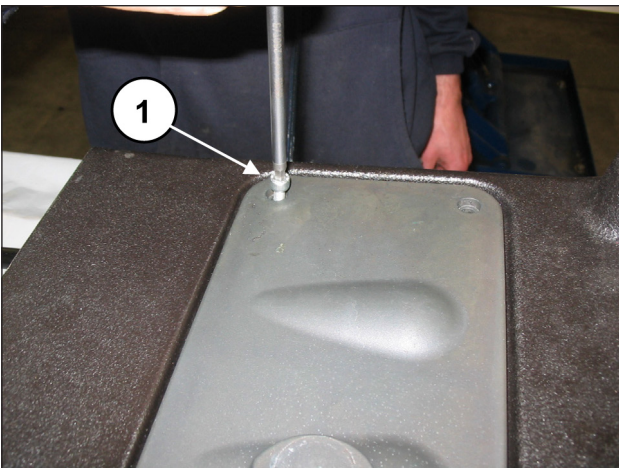

Abb. 165



Abb. 166

Bauen Sie den bearbeiteten Kopf durch Setzen der Buchsen (Pos. ①) samt Stützringen (Pos. ②) und O-Ring (Pos. ③) gemäß Abb. 167 für LK36-40-45 und gemäß Abb. 168 für LK50-55-60 ein:

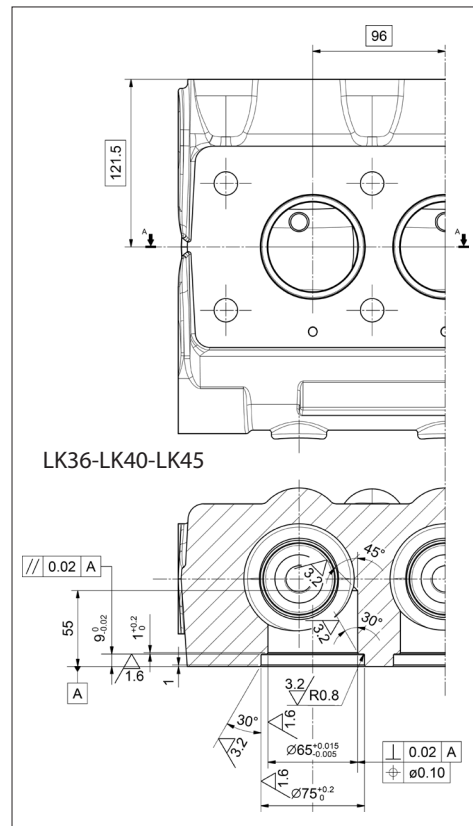

Abb. 167

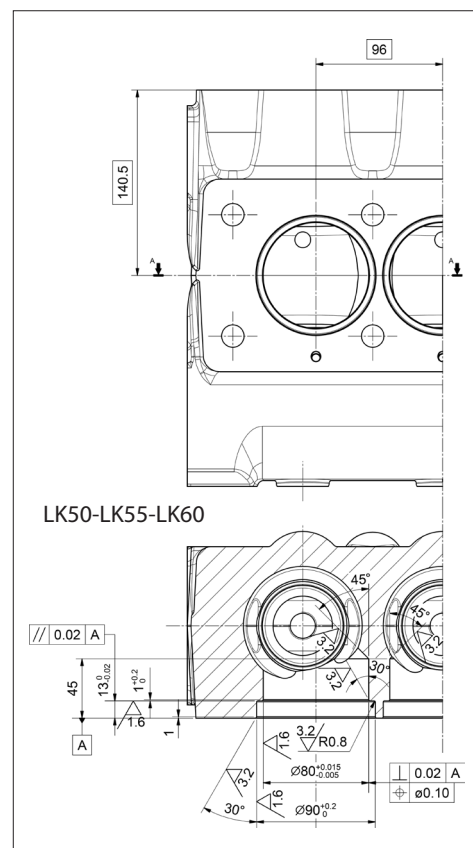
- 1 - Buchse LK36-40-45 - Art. 78216756 - Menge 3
- 2 - Stützring - Art. 90526880 - Menge 6
- 3 - O-Ring - Art. 90410200 - Menge 6

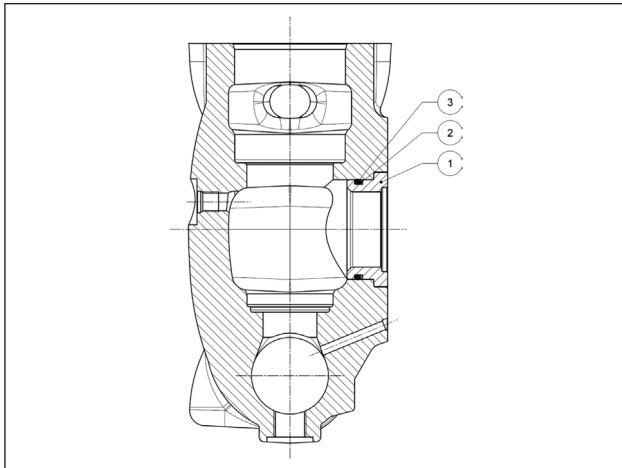

Abb. 168

- 1 - Buchse LK50-55-60 - Art. 78216656 - Menge 3
- 2 - Stützring - Art. 90528500 - Menge 6
- 3 - O-Ring - Art. 90412900 - Menge 6

3 EICHWERTE FÜR DEN SCHRAUBENANZUG

Ziehen Sie die Schrauben ausschließlich mit einem Drehmomentschlüssel fest.

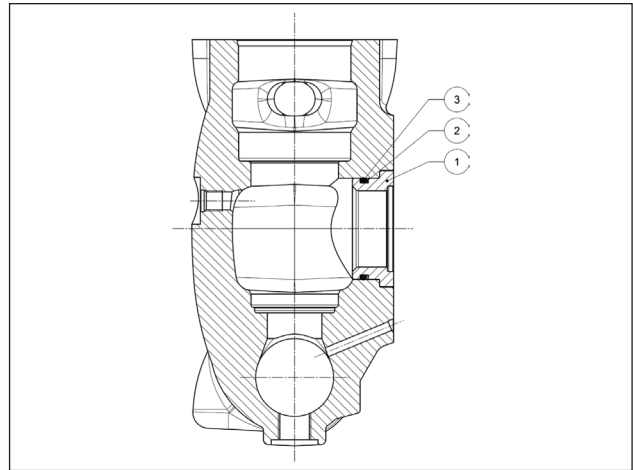
Beschreibung	Position Explosionszeichnung	Anzugsmoment Nm
Schraube M8x20 Gehäusedeckel	54	25
Verschluss G1/2x13 Gehäuse	78	40
Schraube M8x30 Zapfwellen-Lagerdeckel	95	25
Schraube M8x20 Wellenenddeckel	54	25
Schraube M10x30 Lagerdeckel	69	45
Schraube M6x14 oberer und unterer Deckel	82	10
Schraube M8x20 Lagerdeckel	54	25
Schraube M12x1.25x87 Pleuelbefestigung	52	75*
Schraube M6x20 Kolbenführung	49	10
Schraube M12x25 Buchsenflansch	63	68.5
Schraube M10x160 Kolbenbefestigung	27	40
Schraube M16x55 Ventildeckel	26	333
Verschluss G1/4"x13 Kopf	13	40
Schraube M16x150 Kopf	25	333**
Ventilöffner	2	40

* Ziehen Sie alle Schrauben gleichzeitig bis auf Anzugsmoment fest.

** Ziehen Sie die Schrauben von den 4 Innenschrauben ausgehend über Kreuz an (siehe Abb. 135), setzen Sie den Anzug dann mit den 4 Außenschrauben ebenfalls über Kreuz fort.

4 REPARATURWERKZEUGE

Die Wartung der Pumpe kann durch einfache Aus- und Einbauwerkzeuge erfolgen. Folgende Werkzeuge sind verfügbar:

Für den Einbau:

Radialer Dichtring Kolbenführung	Art. 27910900
Radialer Dichtring Zapfwelle	Art. 27539500
	Art. 27548200
O-Ring Druckventilsitz LK36-LK40-LK45	Art. 27516000
O-Ring Druckventilsitz LK50-LK55-LK60	Art. 27516100

Für den Ausbau:

O-Ring Saugventilsitz LK36-LK40-LK45	Art. 27516200
O-Ring Saugventilsitz LK50-LK55-LK60	Art. 27516300
Druckventilsitz	Art. 27516400
Gruppe Buchse + Dichtungshalter	Art. 27516600
Welle (Pleuelbefestigung)	Art. 27566200

5 SPEZIALVERSIONEN

Im Nachhinein finden Sie die Anweisungen zur Reparatur der Spezialversionen. Soweit nicht anders angegeben, gelten die vorstehenden Angaben für die Pumpen LK in Standardversion.

- Pumpen LKN: für die Reparatur gelten die Anweisungen der Pumpen LK in Standardversion.

6 AUSTAUSCH DER PLEUELAUGENBUCHSE

Führen Sie das Setzen der Buchse und die anschließenden Bearbeitungen im Kaltzustand aus und beachten Sie dabei die Maße und Toleranzen gemäß Abb. 169.



Abb. 169

Índice

1	INTRODUCCIÓN	138
1.1	DESCRIPCIÓN DE LOS SÍMBOLOS	138
2	DECLARACIÓN DE REPARACIÓN	138
2.1	REPARACIÓN DE LA PARTE MECÁNICA	138
2.1.1	<i>Desmontaje de la parte mecánica.....</i>	<i>138</i>
2.1.2	<i>Montaje de la parte mecánica.....</i>	<i>146</i>
2.1.3	<i>Clases de mayoraciones previstas</i>	<i>156</i>
2.2	REPARACIÓN DE LA PARTE HIDRÁULICA	156
2.2.1	<i>Desmontaje de la cabeza - grupos de válvulas</i>	<i>156</i>
2.2.2	<i>Montaje de cabeza – grupos de válvulas.....</i>	<i>158</i>
2.2.3	<i>Desmontaje del grupo pistón - soportes - juntas</i>	<i>162</i>
2.2.4	<i>Montaje del grupo pistón - soportes - juntas</i>	<i>164</i>
2.2.5	<i>Recuperación de cabezas.....</i>	<i>167</i>
3	CALIBRACIÓN DE AJUSTE DE LOS TORNILLOS	168
4	HERRAMIENTAS DE REPARACIÓN	169
5	VERSIONES ESPECIALES.....	169
6	SUSTITUCIÓN DEL CASQUILLO PIE DE LA BIELA	170

1 INTRODUCCIÓN

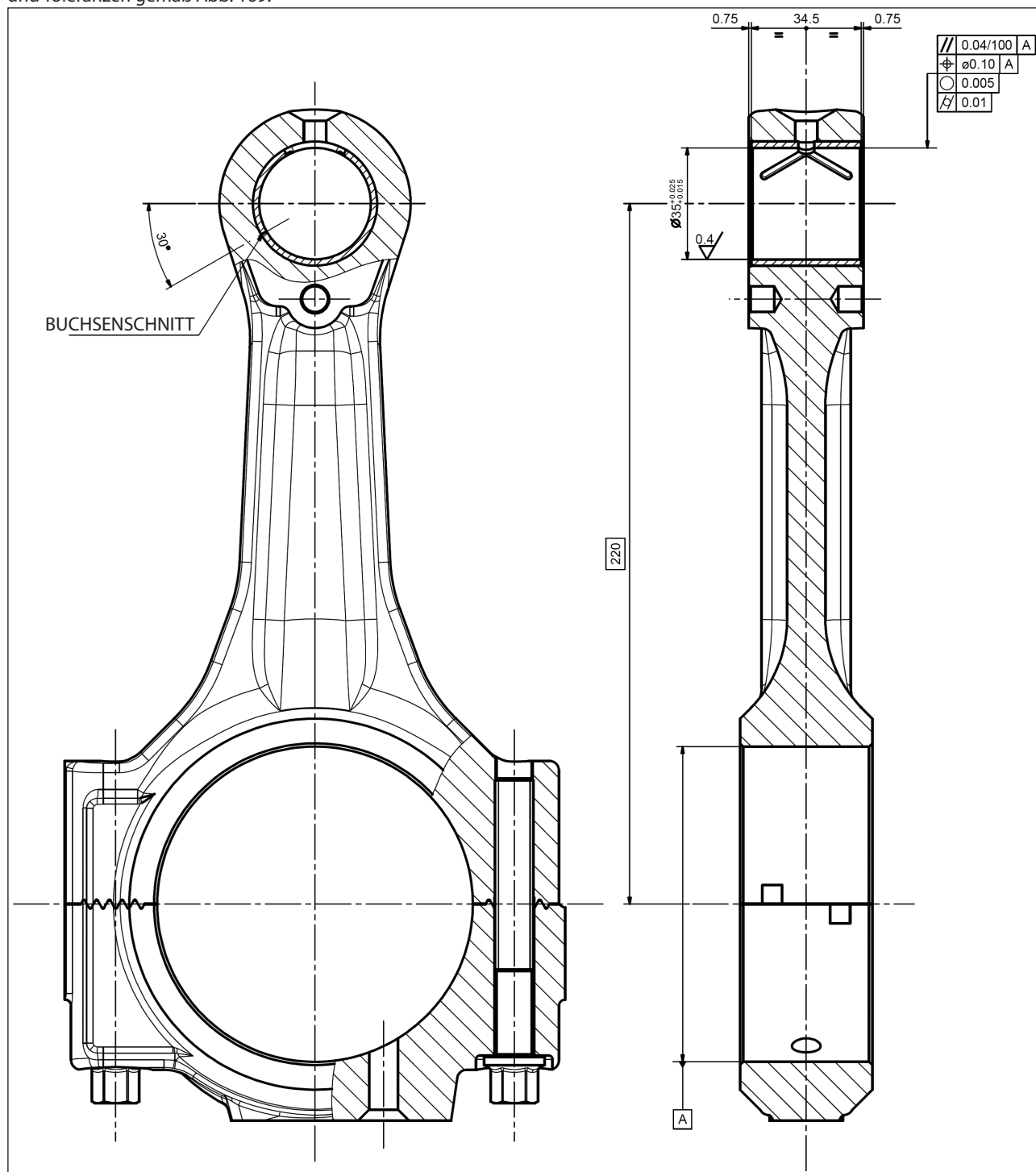
Este manual describe las instrucciones para la reparación de las bombas LK y debe ser atentamente leído y comprendido antes de utilizar la bomba.

De un correcto uso y un mantenimiento adecuado depende el funcionamiento regular y la duración de la bomba.

Interpump Group no se responsabiliza de los daños causados por negligencia o falta de observación de las normas descritas sobre el presente manual.

1.1 DESCRIPCIÓN DE LOS SÍMBOLOS

Leer atentamente lo indicado en el presente manual antes de realizar cada operación.



Señal de advertencia



Leer atentamente lo indicado en el presente manual antes de realizar cada operación.



Señal de Peligro

Utilizar gafas de protección



Señal de Peligro

Utilizar guantes de protección para realizar cualquier tipo de operación

2 DECLARACIÓN DE REPARACIÓN



2.1 REPARACIÓN DE LA PARTE MECÁNICA

Las operaciones de reparación de la parte mecánica deben ser realizadas después de haber retirado todo el aceite del cárter. Para eliminar el aceite es necesario quitar el tapón de llenado pos. ①, Fig. 1 y a continuación el tapón de descarga pos. ②, Fig. 1.

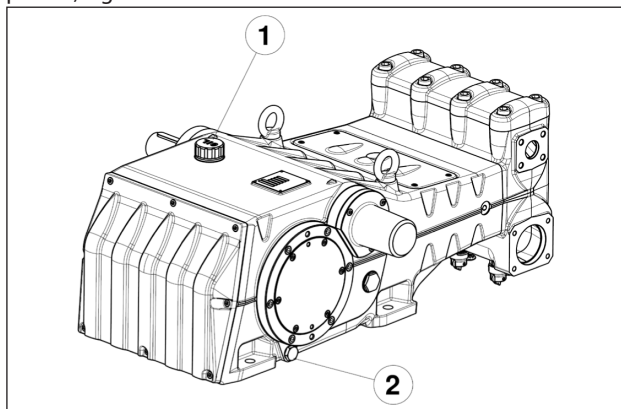

Fig. 1



El aceite agotado debe ser colocado en un recipiente adecuado y eliminado en los correspondientes centros. No debe dispersarse en el ambiente.

2.1.1 Desmontaje de la parte mecánica

La secuencia correcta es la siguiente:

Vaciar el aceite contenido en la bomba, como se indica en el apart. 2.1.

Desmontar los alza válvulas de la cabeza y la cabeza del cárter de la bomba como se indica en el apart. 2.2.1 (de Fig. 103 a Fig. 105).

Quitar las tapas de inspección superior e inferior aflojando los 4+4 tornillos de fijación como se indica en el apart. 2.2.3 (Fig. 139 y Fig. 140).

Extraer las juntas tóricas y sustituirlas si es necesario.

Desmontar los tres pistones y los grupos camisas-soportes de juntas como se indica en el apart. 2.2.3 (Fig. 138, Fig. 141 y Fig. 142).

Desmontar las tres anillas de las protecciones contra salpicaduras y las protecciones contra salpicaduras como se indica en el apart. 2.2.3 (Fig. 143 y Fig. 144).

Aflojar los tornillos prisioneros de bloqueo M6 de las tres tapas de retención (pos. ①, Fig. 2).

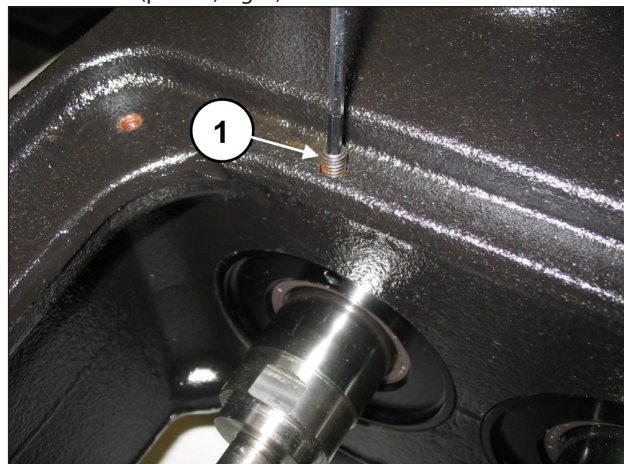

Fig. 2

Enroscar una barra roscada o un tornillo M6, para que actúe como extractor, en los orificios de la tapa de retención (pos. ①, Fig. 3) y extraer las tapas del grupo de la bomba (pos. ①, Fig. 4).

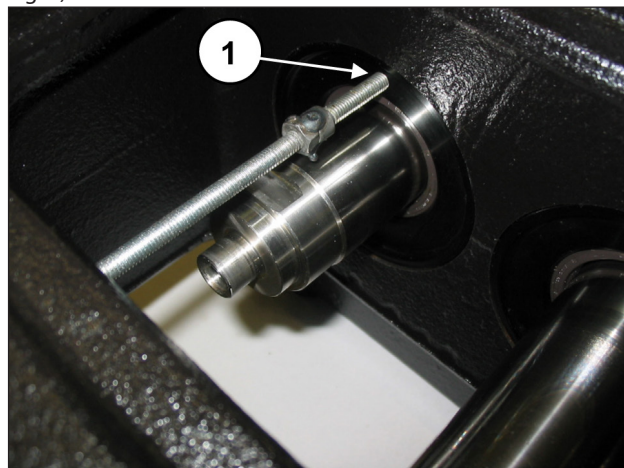

Fig. 3

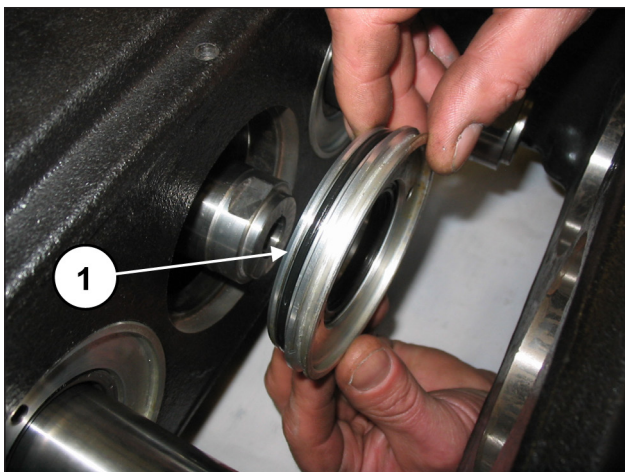

Fig. 4

Extraer la anilla de retención radial (pos. ①, Fig. 5) y la anilla restop (pos. ①, Fig. 6).

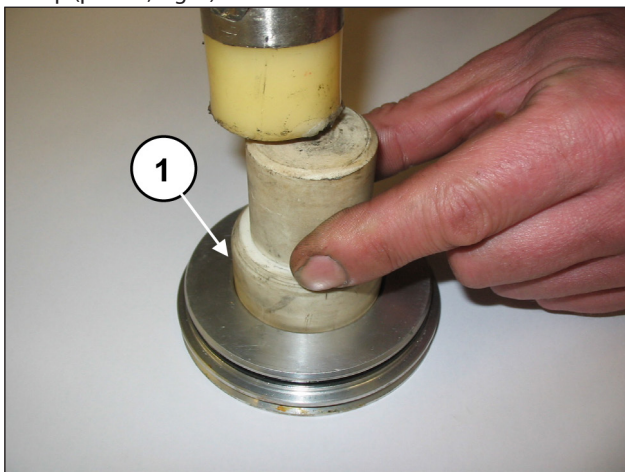

Fig. 5

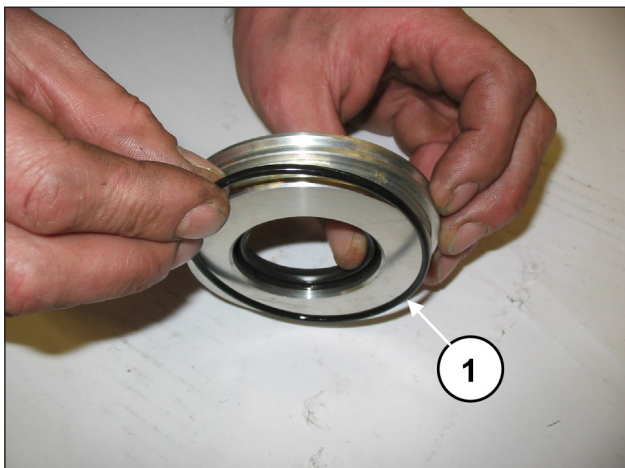

Fig. 6

Desmontar la lengüeta del eje PTO (pos. ①, Fig. 7).

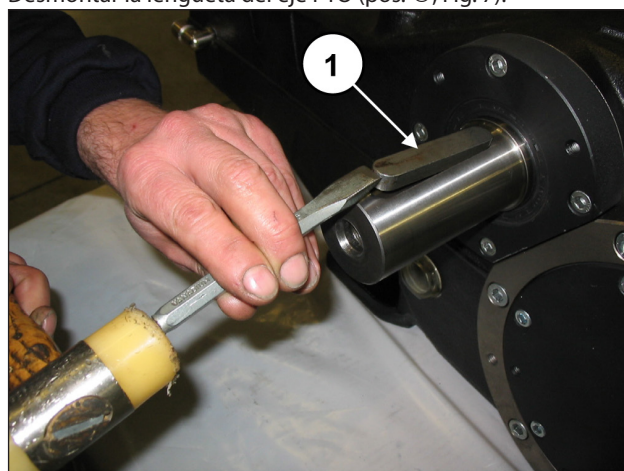

Fig. 7

Aflojar los tornillos de fijación de la tapa del extremo del eje (pos. ①, Fig. 8) y extraer la tapa del eje PTO.

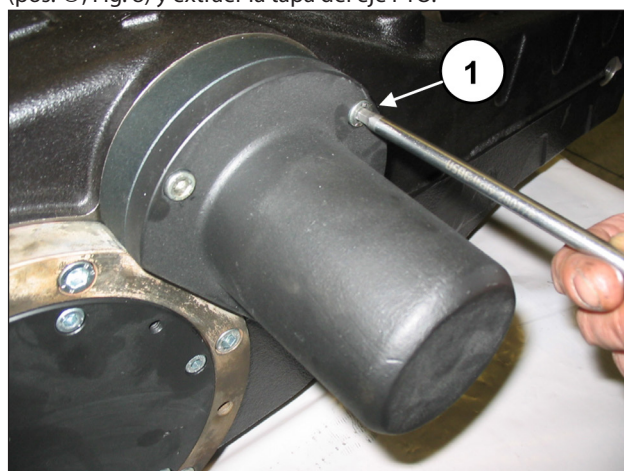

Fig. 8

Aflojar los tornillos de fijación de la tapa del cárter (pos. ①, Fig. 9) y desmontarlo. Extraer la junta tórica y sustituirla si es necesario.



Fig. 9

Desmontar las dos tapas del cojinete aflojando los tornillos (pos. ①, Fig. 10).

Para facilitar el desmontaje, utilizar 2 tornillos prisioneros o tornillos M8 (pos. ①, Fig. 11) como extractores.

Extraer la junta tórica y sustituirla si es necesario.

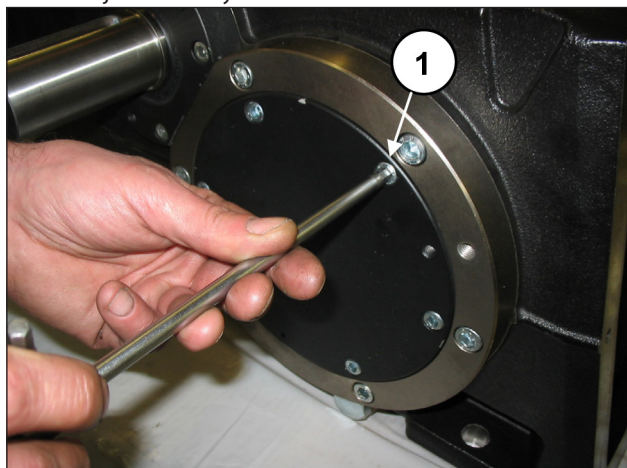

Fig. 10

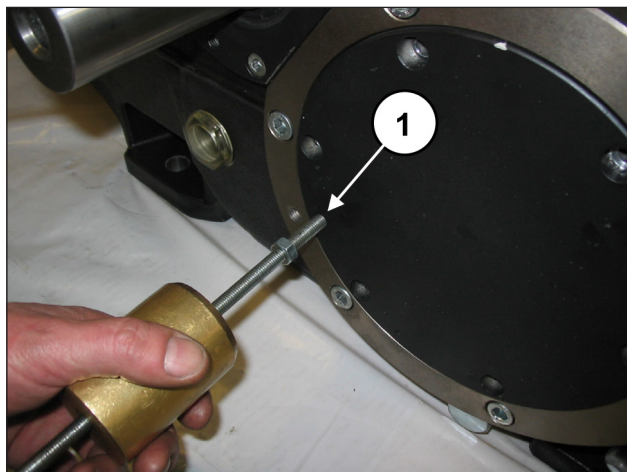

Fig. 11

Introducir un espesor debajo del cilindro de la biela central para bloquear la rotación del eje acodado (pos. ①, Fig. 12).

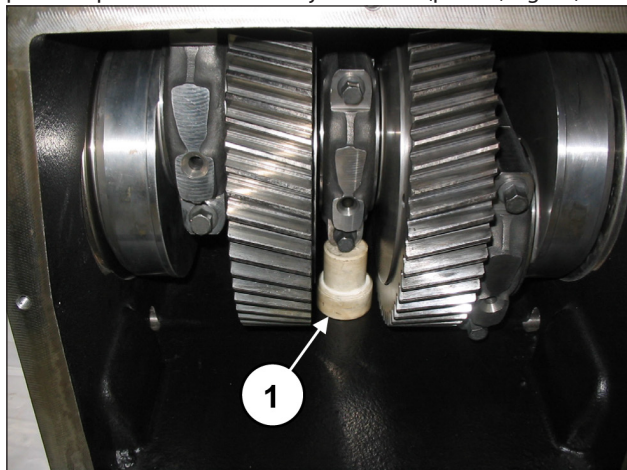

Fig. 12

Aflojar y extraer los tornillos de fijación de la brida de bloqueo del casquillo, en ambos lados (pos. ①, Fig. 13).

No desmontar las bridas de bloqueo del casquillo (pos. ①, Fig. 14).

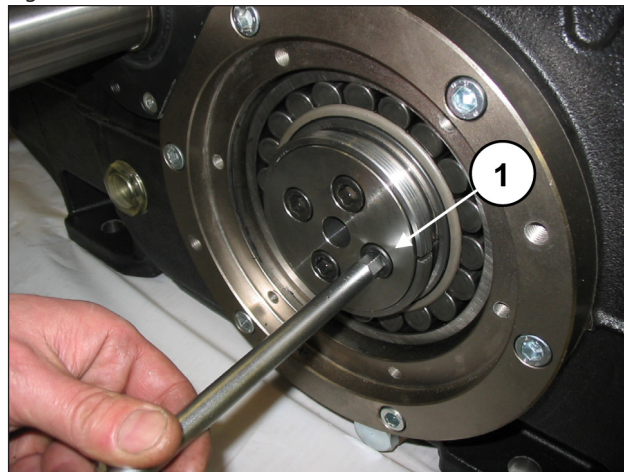

Fig. 13

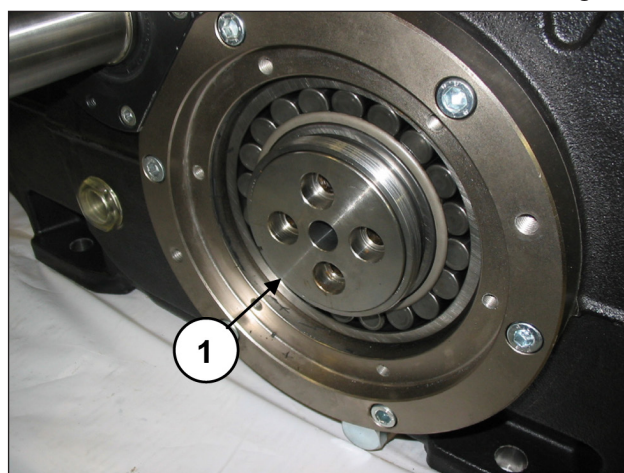

Fig. 14

En uno de los lados, enroscar una corona de tipo SKF KM20 en el casquillo de presión (pos. ①, Fig. 15) y desbloquear el casquillo con una herramienta de percusión (pos. ①, Fig. 16), sin extraerlo.

Repetir la operación en el lado opuesto.

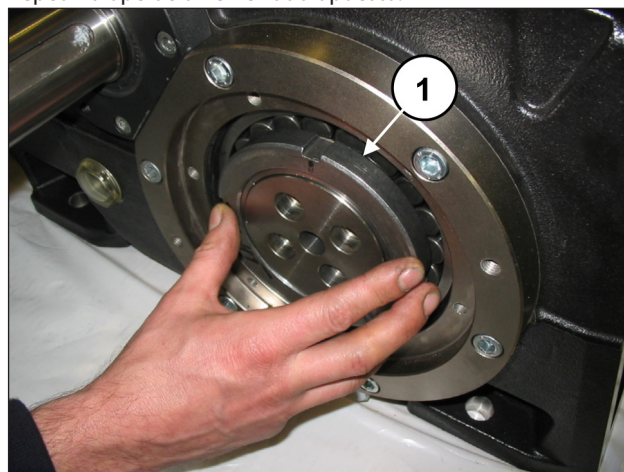

Fig. 15

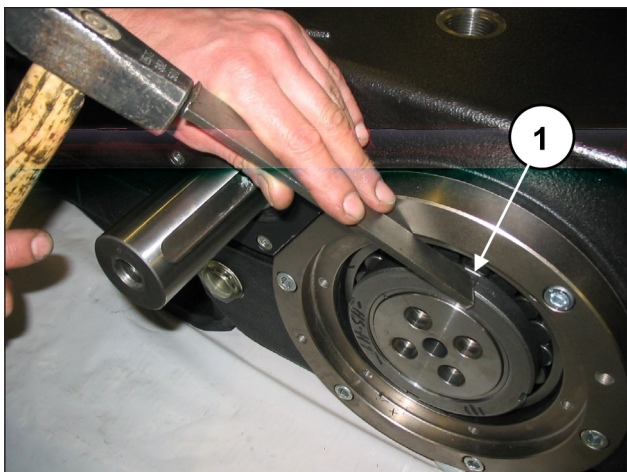

Fig. 16

Quitar el espesor que hay debajo del cilindro de la biela central.

Aflojar los tornillos de la biela (pos. ①, Fig. 17).

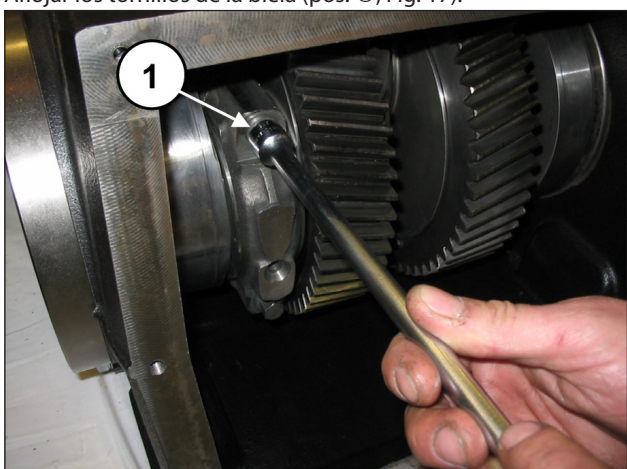

Fig. 17

Desmontar los sombreretes de la biela con los semicojinetes, controlando el orden de desmontaje.



Al montar los sombreretes de la biela y sus semibielas se deben respetar el orden y el emparejamiento de desmontaje.

Para evitar posibles errores, sombreretes y semibielas han sido enumerados en un lateral (pos. ①, Fig. 18).

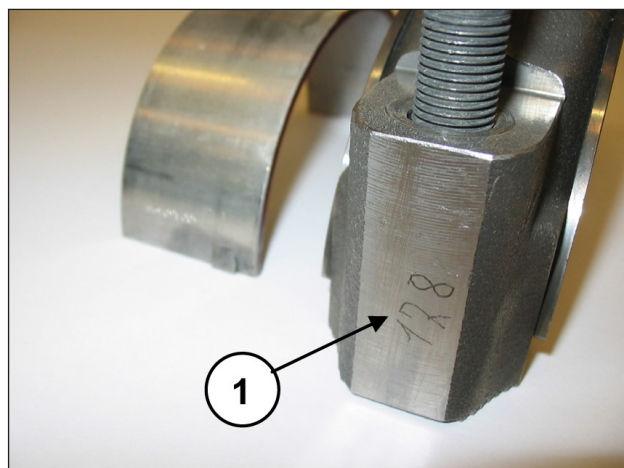
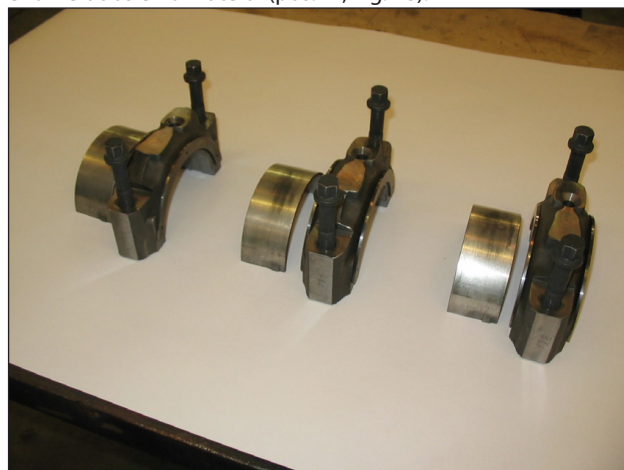

Fig. 18

Desplazar las tres semibielas en la dirección del cabezal hasta el final de carrera.

Extraer los 3 semicojinetes superiores de las semibielas (pos. ①, Fig. 19).

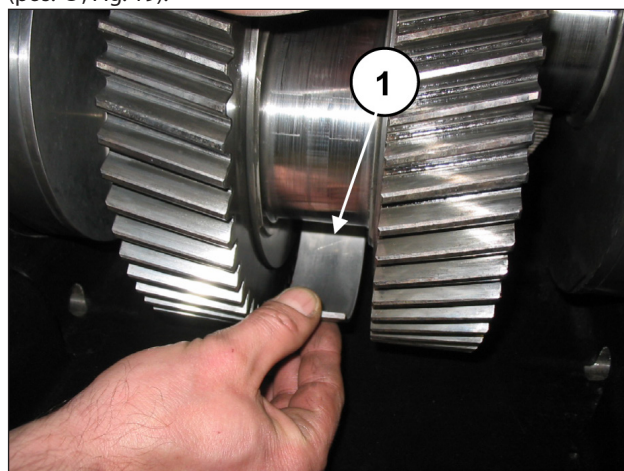

Fig. 19

Desmontar los dos casquillos de presión (pos. ①, Fig. 20).

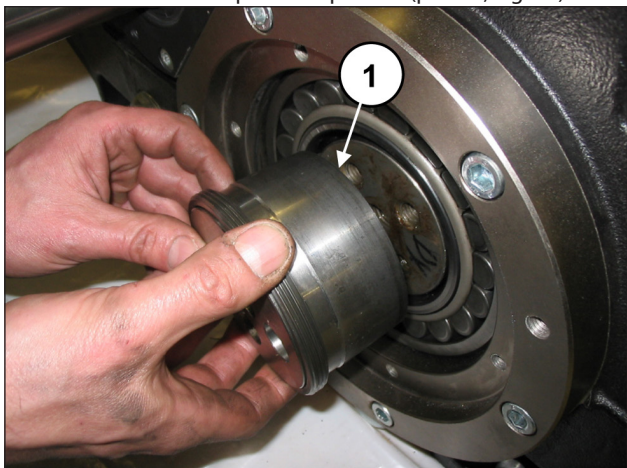

Fig. 20

Separar la brida que bloquea el casquillo del casquillo de presión (pos. ①, Fig. 21).

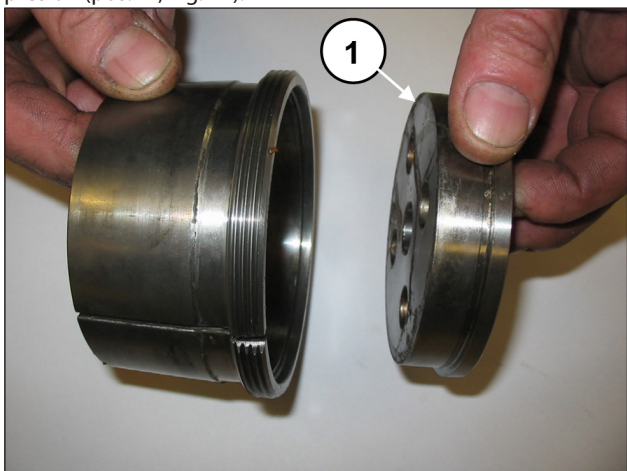

Fig. 21

Aflojar los tornillos de las dos tapas portacojinetes (pos. ①, Fig. 22).

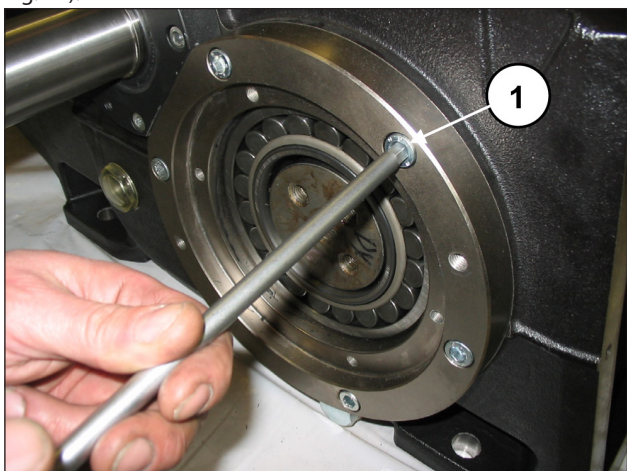

Fig. 22

Aplicar un perno roscado M16 en un extremo del eje acodado (pos. ①, Fig. 23) y, manteniéndolo levantado, extraer la tapa portacojinetes junto con la junta tórica (pos. ①, Fig. 24). Para facilitar el desmontaje, utilizar 2 tornillos prisioneros o tornillos M10 (pos. ②, Fig. 23) como extractores. Repetir la operación en el lado opuesto.

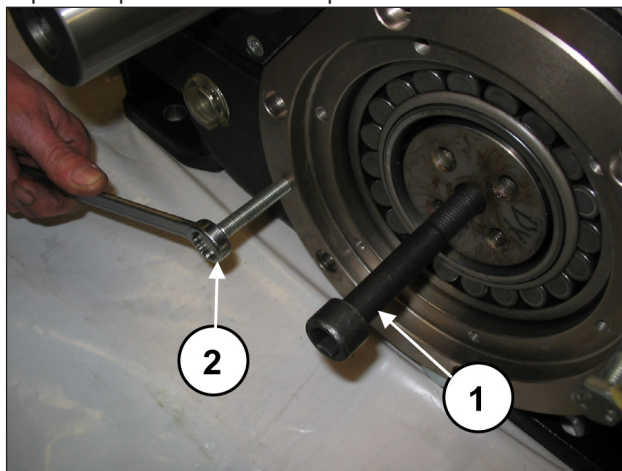

Fig. 23

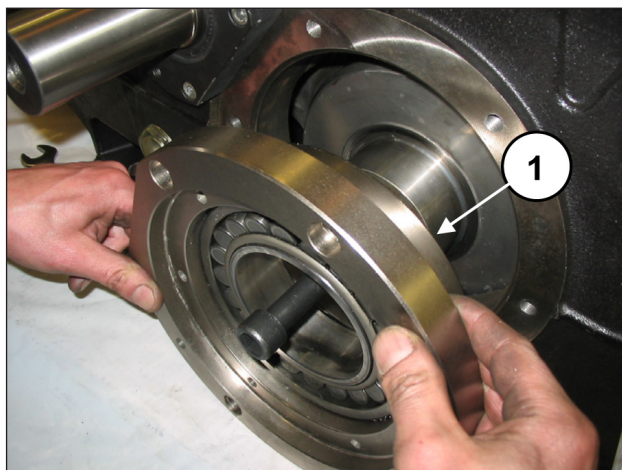

Fig. 24

Apoyar el eje acodado sobre el fondo del cárter. Separar la tapa portacojinetes del cojinete utilizando una herramienta de percusión (pos. ①, Fig. 25).

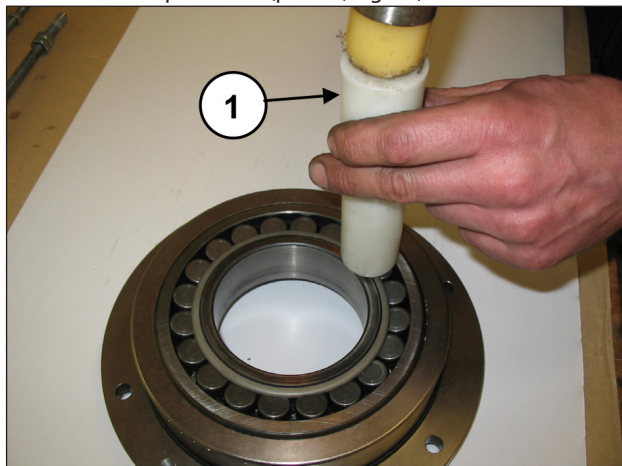

Fig. 25

Aflojar los tornillos de fijación de la tapa del cojinete PTO derecho e izquierdo (pos. ①, Fig. 26) y extraer las dos tapas del eje PTO. Para facilitar el desmontaje, utilizar 3 tornillos prisioneros o tornillos M8 (pos. ①, Fig. 27) como extractores.

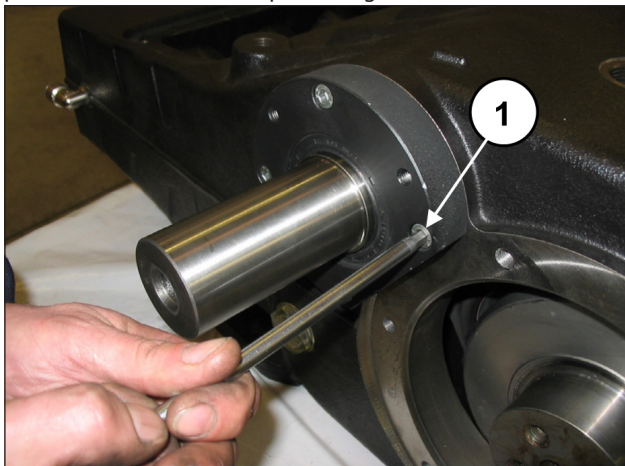

Fig. 26

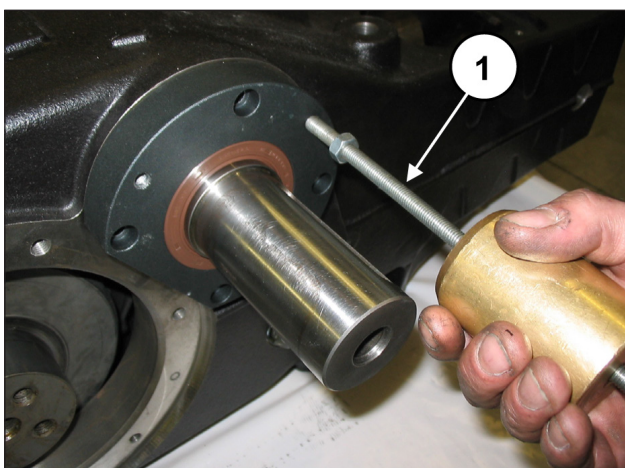

Fig. 27

Extraer la anilla de retención radial (pos. ①, Fig. 28), la junta tórica externa (pos. ①, Fig. 29) y la junta tórica del orificio de lubricación (pos. ①, Fig. 30).

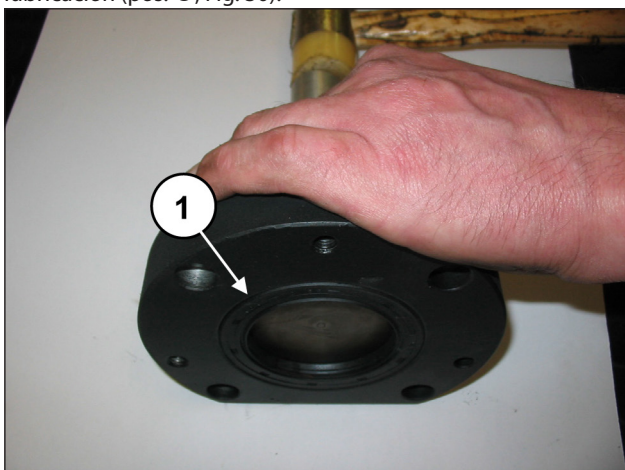

Fig. 28

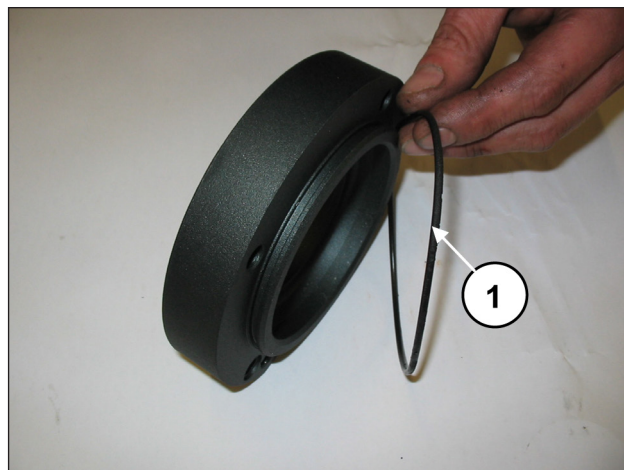

Fig. 29

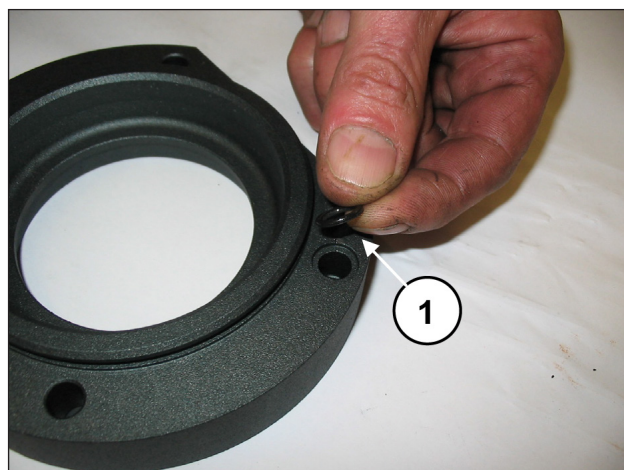

Fig. 30

Desplazar hacia atrás las tres bielas hasta el final de carrera, de manera que estén en contacto con el eje acodado. Utilizando una herramienta de percusión (pos. ①, Fig. 31), extraer el eje PTO por uno de los dos lados (pos. ①, Fig. 32).

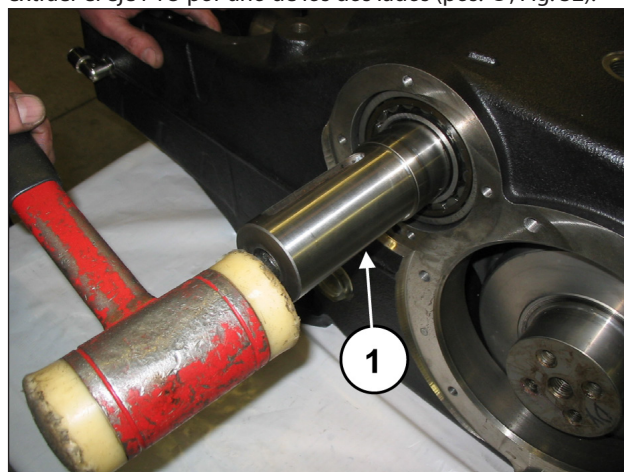

Fig. 31

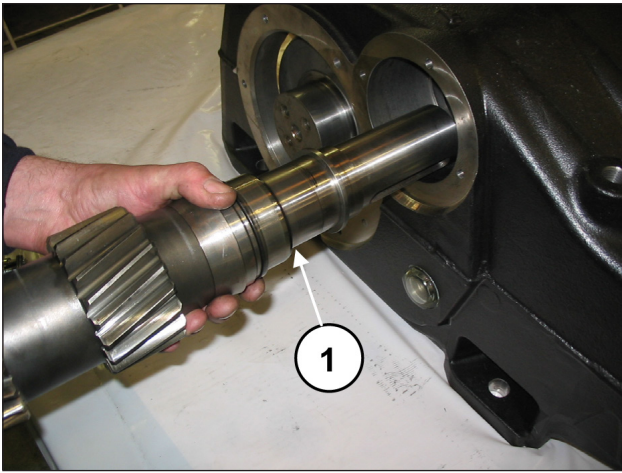

Fig. 32

Extraer las anillas internas de los cojinetes del eje PTO (pos. ①, Fig. 33) y los dos distanciadores del cojinete interno (pos. ②, Fig. 33).

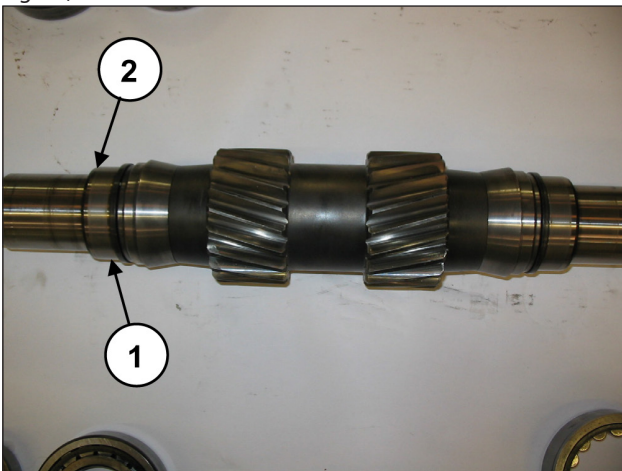

Fig. 33



Las anillas internas y externas de los cojinetes se han de montar exactamente en el mismo orden y con el mismo emparejamiento de desmontaje.

Utilizando una herramienta lo suficientemente larga (pos. ①, Fig. 34) y una herramienta de percusión, extraer las anillas de los cojinetes del cárter de la bomba (pos. ①, Fig. 35), el distanciador del cojinete externo (pos. ①, Fig. 36) y el casquillo de lubricación de los cojinetes (pos. ①, Fig. 37).

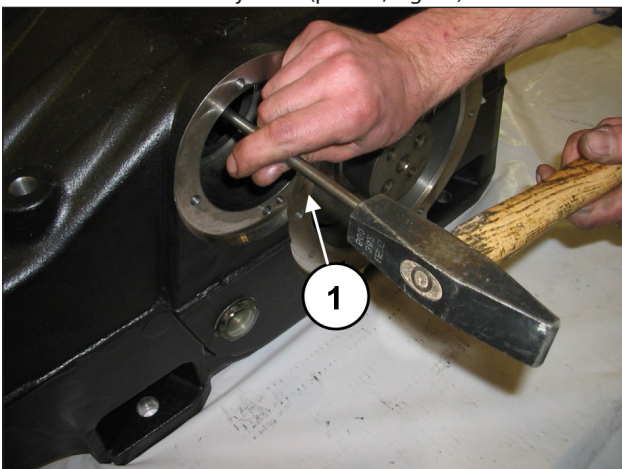

Fig. 34

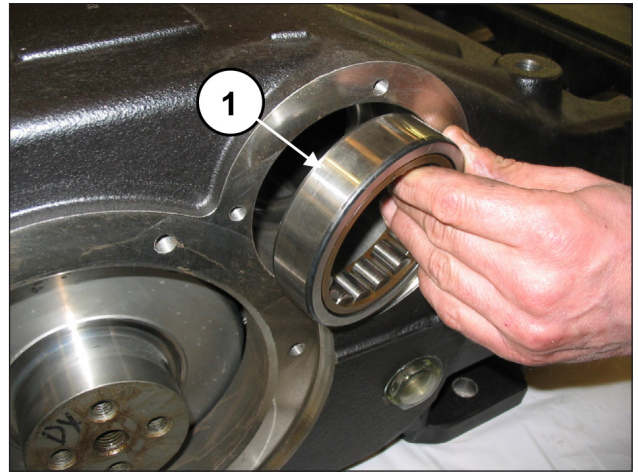

Fig. 35

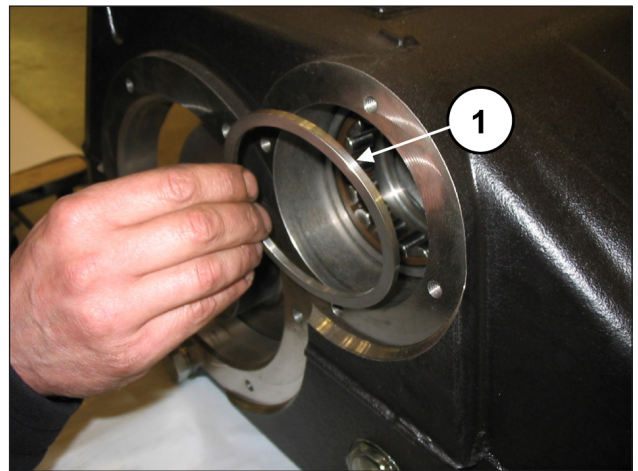

Fig. 36

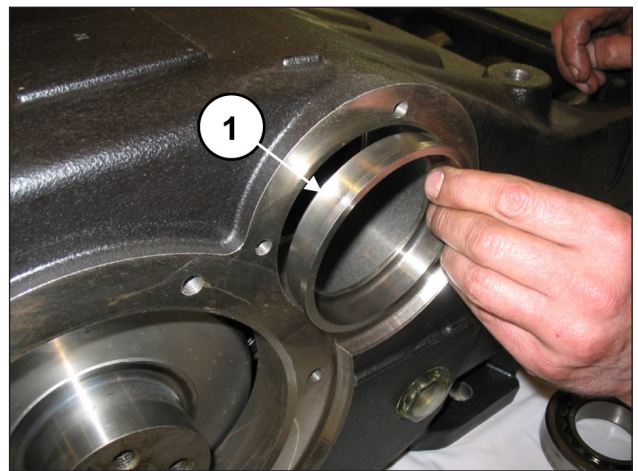

Fig. 37

Desplazar las semibielas hacia la parte hidráulica y bloquearlas con la herramienta específica (cód. 27566200) (pos. ①, Fig. 38).

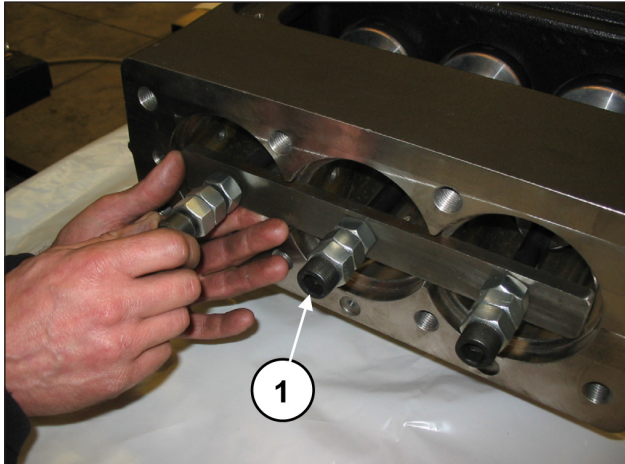

Fig. 38

Extraer el eje acodado por la parte posterior del cárter (pos. ① pos. ①, Fig. 39).

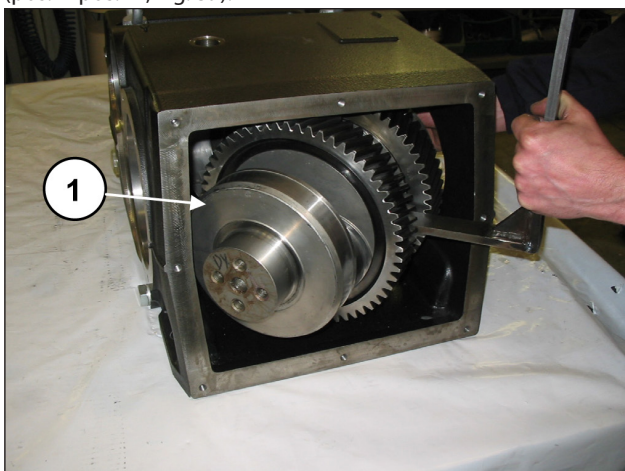

Fig. 39

Aflojar los tornillos de la herramienta cód. 27566200 para desbloquear las bielas (pos. ①, Fig. 40) y, a continuación, extraer los grupos biela-guía del pistón por la abertura posterior del cárter (pos. ①, Fig. 41).

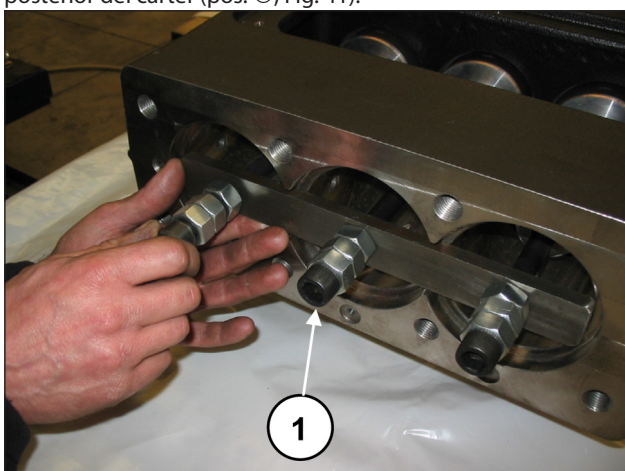

Fig. 40

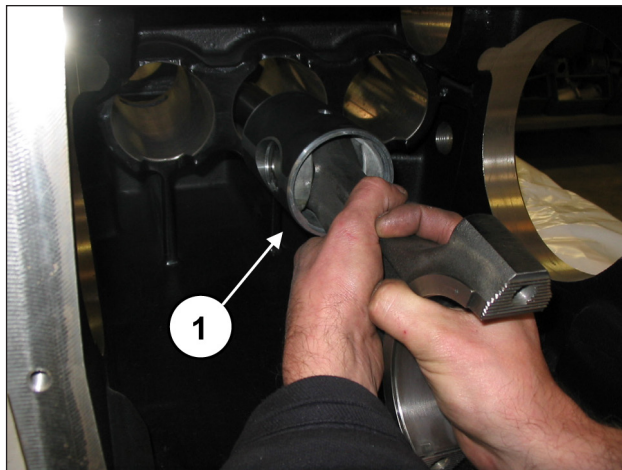

Fig. 41

Acoplar las semibielas en los sombreretes ya desmontados, controlando la numeración (pos. ①, Fig. 42).

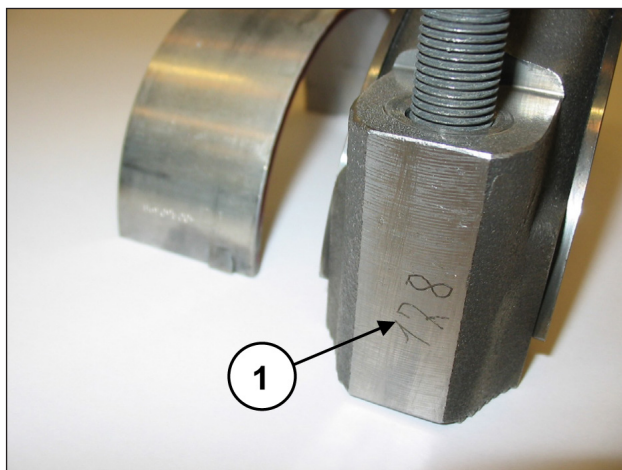
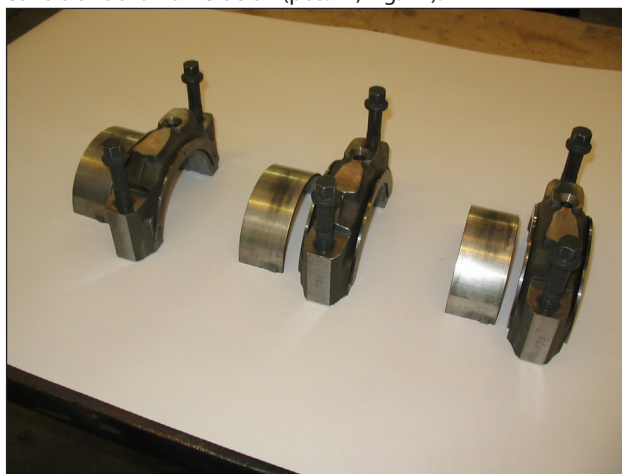

Fig. 42

Desmontar las 2 anillas seeger de bloqueo de la clavija utilizando la herramienta específica (pos. ①, Fig. 43).

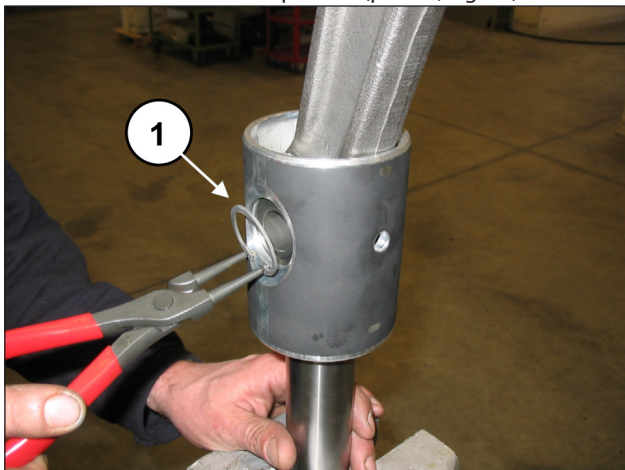

Fig. 43

Extraer la clavija (pos. ①, Fig. 44) y, a continuación, la biela (pos. ①, Fig. 45).

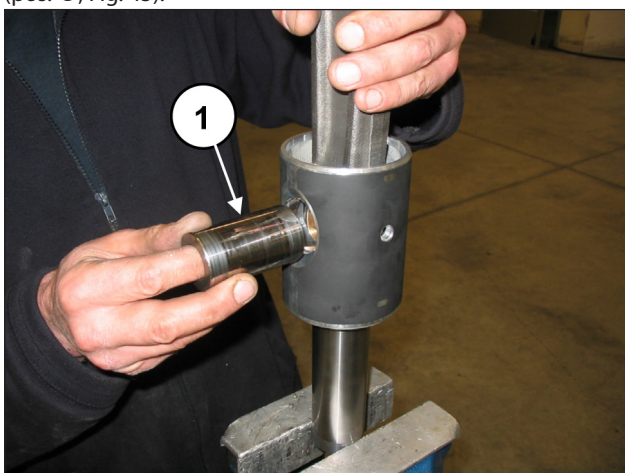

Fig. 44

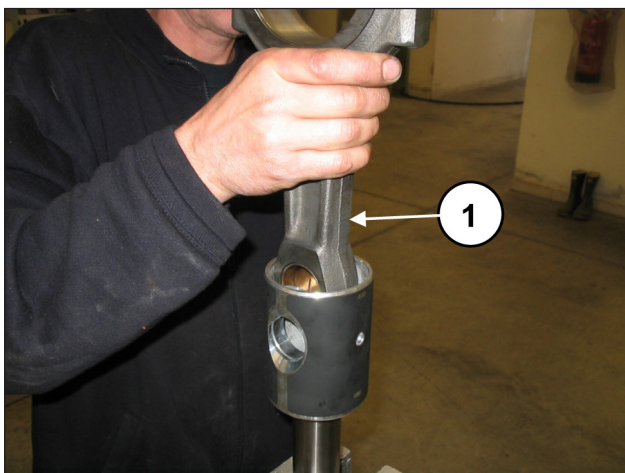

Fig. 45

Para separar el vástago de la guía del pistón, es necesario aflojar los tornillos de cabeza cilíndrica M6 con la llave específica (pos. ①, Fig. 46).

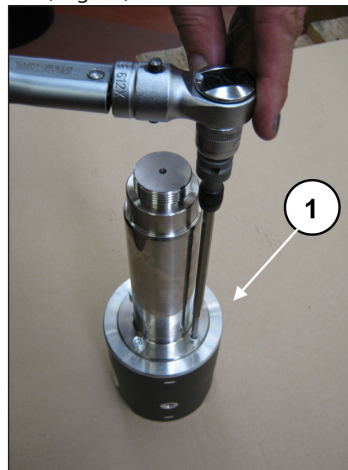

Fig. 46

Para terminar la fase de desmontaje de la parte mecánica, desmontar los testigos de nivel del aceite y los cáncamos.

2.1.2 Montaje de la parte mecánica

Seguir en orden contrario la secuencia de desmontaje descrita en el apart. 2.1.1.

La secuencia correcta es la siguiente:

Montar los dos testigos del nivel de aceite, los dos tapones de descarga del aceite y el racor con la conexión rápida a 90° (pos. ①, ② y ③ Fig. 47).

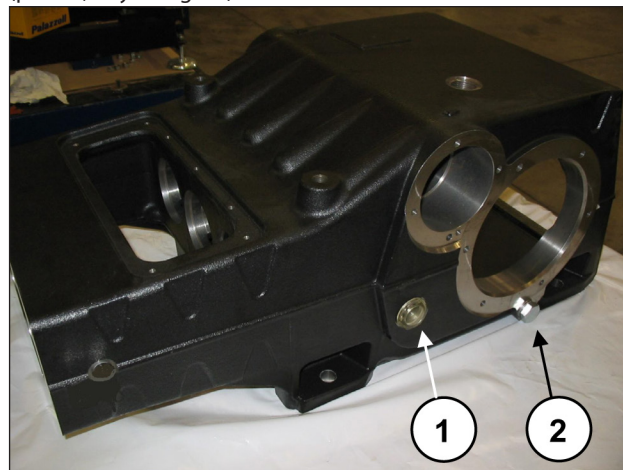

Fig. 47

Ensamblar el vástago en la guía del pistón.

Introducir el vástago de guía del pistón en el alojamiento de la guía del pistón (pos. ①, Fig. 48) y fijarlo con los 4 tornillos de cabeza cilíndrica M6x20 (pos. ①, Fig. 49).



Fig. 48

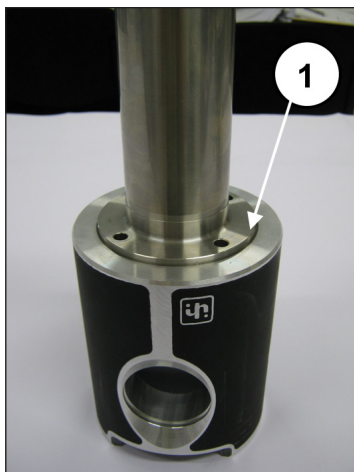

Fig. 49

Bloquear la guía del pistón con la herramienta específica y apretar los tornillos con la llave dinamo-métrica (pos. ①, Fig. 50) como se indica en el capítulo 3.

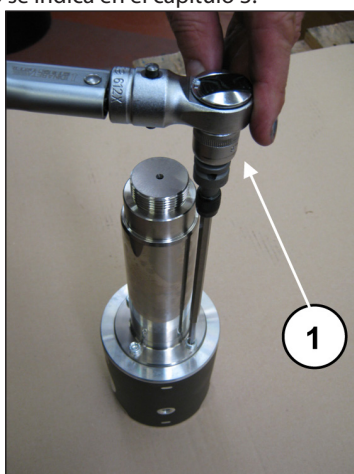

Fig. 50

Introducir la biela en la guía del pistón (pos. ①, Fig. 45) y, a continuación, la clavija (pos. ①, Fig. 44). Aplicar las dos anillas seeger de tope con la herramienta específica (pos. ①, Fig. 43).



Si los componentes están montados correctamente, el pie de biela, la guía del pistón y la clavija debe girar libremente.

Separar los sombreretes de las semibielas; controlar los números laterales para emparejarlos de manera correcta (pos. ①, Fig. 42).

Comprobar que el cárter esté limpio e introducir el grupo semibiela-guía pistón dentro de las levas del cárter (pos. ①, Fig. 41).



Introducir el grupo semibiela-guía del pistón en el cárter de manera que la numeración de las semibielas pueda verse desde arriba.

Bloquear los tres grupos con la herramienta cód. 27566200, (pos. ①, Fig. 40).

Introducir el eje acodado en la apertura posterior del cárter y apoyarlo en el fondo.



Introducir el eje acodado en el cárter de manera que los dientes de las coronas estén orientados como se indica en la Fig. 51.

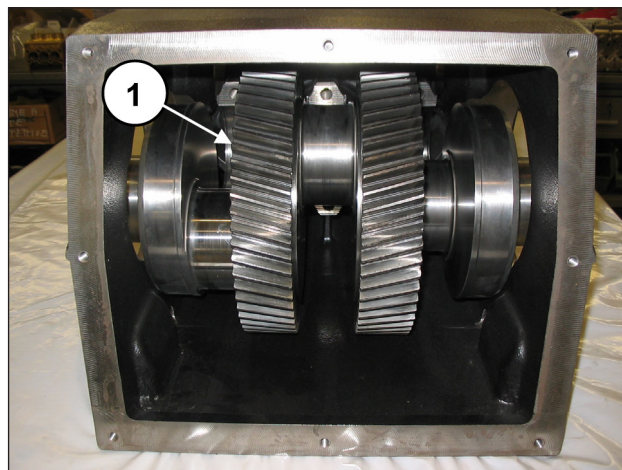

Fig. 51

Premontar el eje PTO: introducir en el eje PTO las 2 anillas internas de los cojinetes (una por cada lado) (pos. ①, Fig. 52).

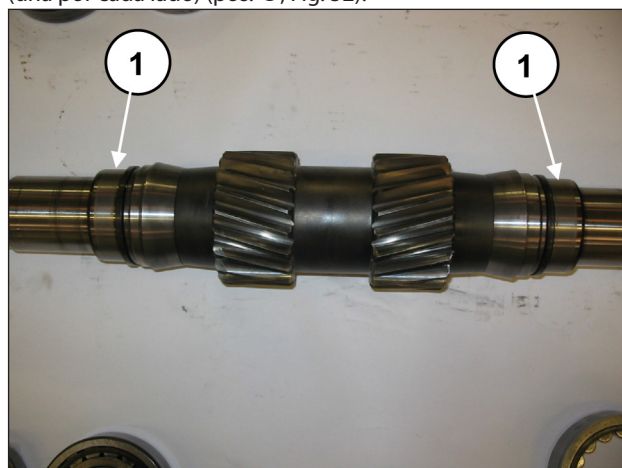

Fig. 52



Las anillas internas y externas de los cojinetes se han de montar exactamente en el mismo orden y con el mismo emparejamiento de desmontaje.

Desde uno de los lados del cárter, introducir el casquillo de lubricación de los cojinetes (pos. ①, Fig. 53) y la anilla externa del cojinete (pos. ①, Fig. 54) utilizando un tampón y una herramienta de percusión.

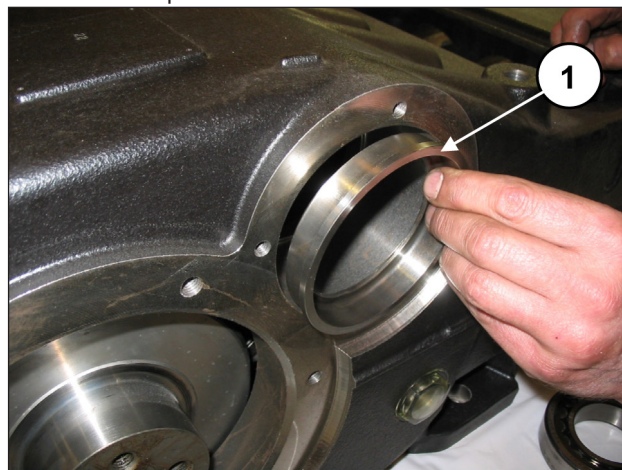

Fig. 53

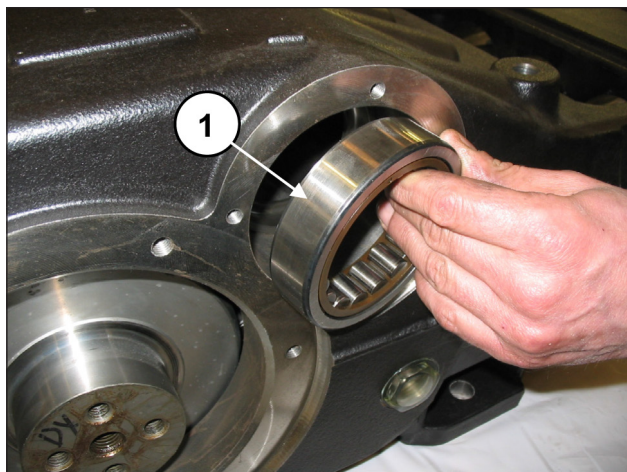

Fig. 54

Desmontar la herramienta que bloquea las bielas cód. 27566200, (pos. ①, Fig. 40) y deslizar las bielas hacia atrás hasta que hagan tope en el eje acodado.

Introducir el eje PTO premontado dentro del cárter (pos. ①, Fig. 55) desde la parte opuesta a la que se han premontado la anilla externa del cojinete y el casquillo de lubricación de los cojinetes.



Introducir el eje acodado PTO en el cárter de manera que los dientes estén orientados como se indica en la Fig. 55.

Para facilitar la introducción a fondo del eje PTO dentro del cojinete, aplicar un tornillo M16 en el extremo del eje que se ha de introducir para mantenerlo alzado (pos. ①, Fig. 56).

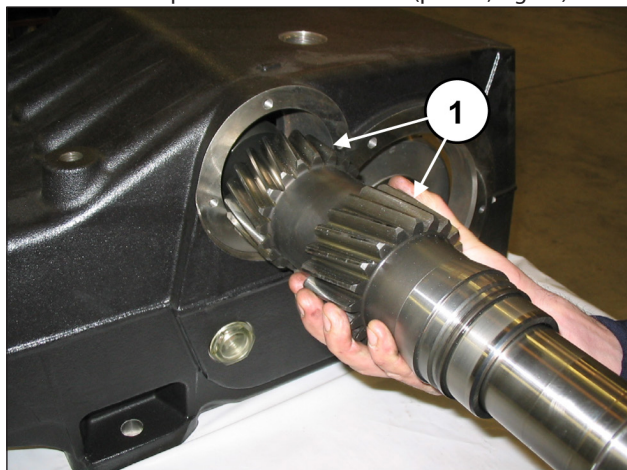

Fig. 55

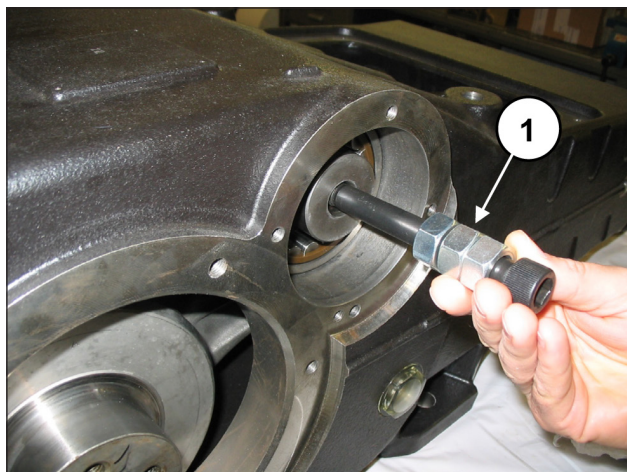

Fig. 56

Desde el lado de introducción del eje PTO, introducir el casquillo de lubricación de los cojinetes (pos. ①, Fig. 57) y la anilla externa del cojinete (pos. ①, Fig. 58) utilizando un tampón y una herramienta de percusión.



Fig. 57

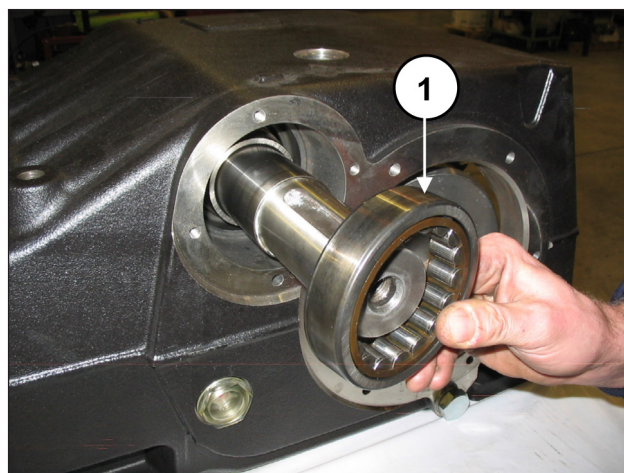

Fig. 58

Desde ambos lados, introducir los distanciadores de los cojinetes interno (pos. ①, Fig. 59) y externo (pos. ①, Fig. 60).

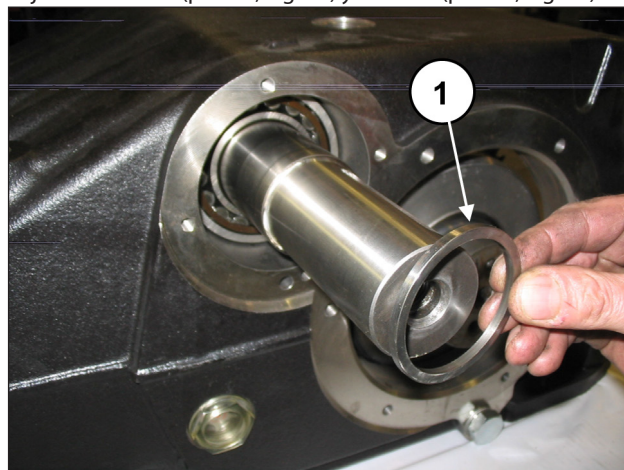

Fig. 59

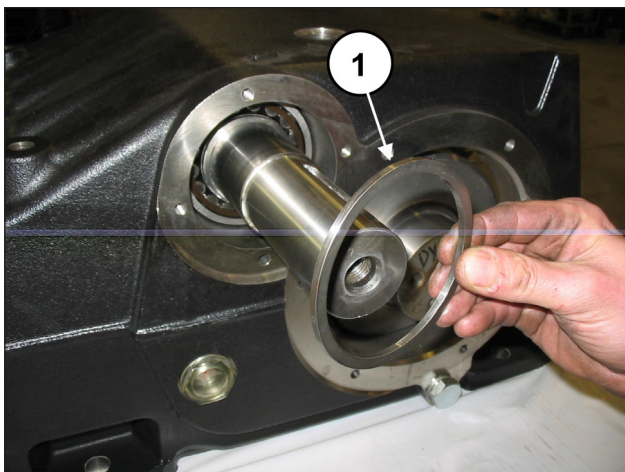

Fig. 60

Introducir la anilla interna (pos. ①, Fig. 61) y la anilla externa (pos. ①, Fig. 62) de un cojinete desde un único lado de la bomba.



Fig. 61

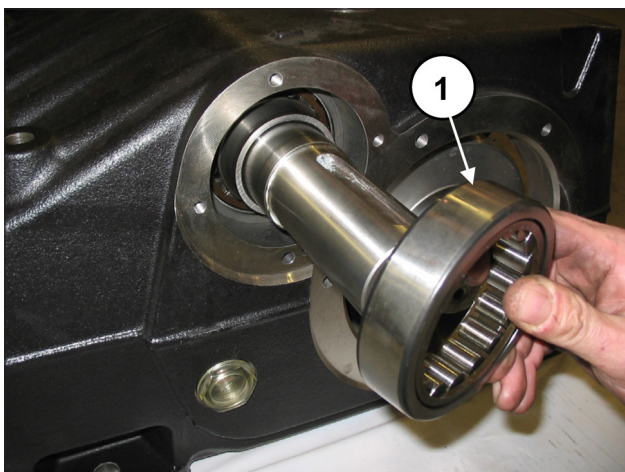

Fig. 62

Premontar las tapas del cojinete PTO derecha e izquierda:

Introducir la anilla de retención radial dentro de la tapa del cojinete PTO utilizando la herramienta cód. 27539500, (pos. ①, Fig. 63).

Antes de montar la anilla de retención radial, comprobar las condiciones del labio de estanqueidad. Si se ha de sustituir, colocar una anilla nueva como se indica en la Fig. 64.



En el caso que el eje PTO presente un desgaste diametral en correspondencia con el labio de retención, con el fin de evitar tener que realizar la operación de rectificación, es posible volver a colocar la anilla en el segundo tope como se indica en la Fig. 64.

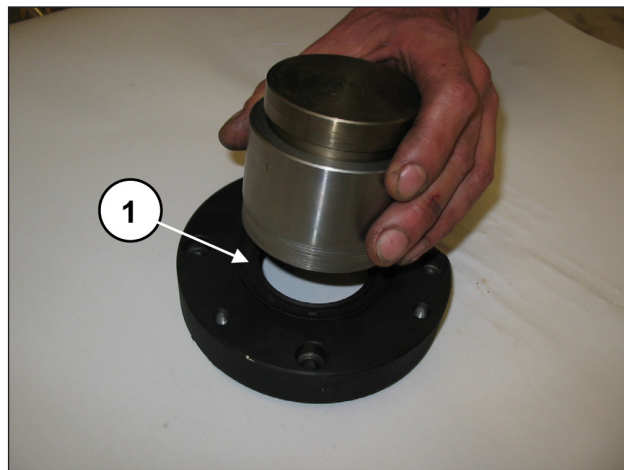

Fig. 63

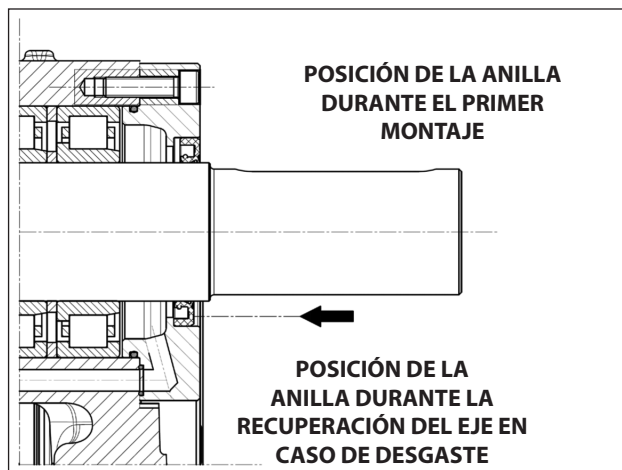

Fig. 64

Aplicar a las tapas del cojinete PTO, la junta tórica externa (pos. ①, Fig. 65) y la junta tórica del orificio de lubricación (pos. ①, Fig. 66).

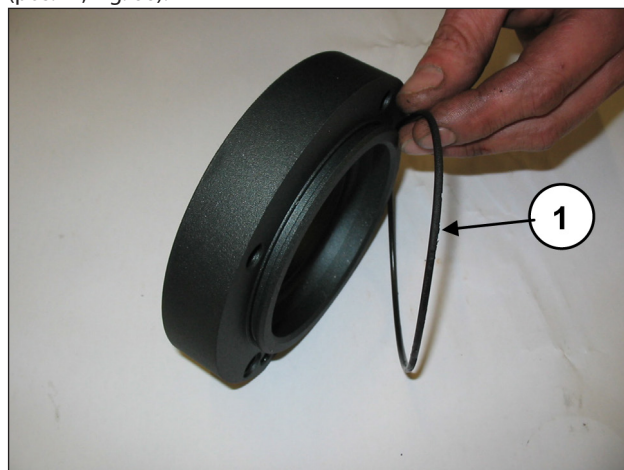

Fig. 65

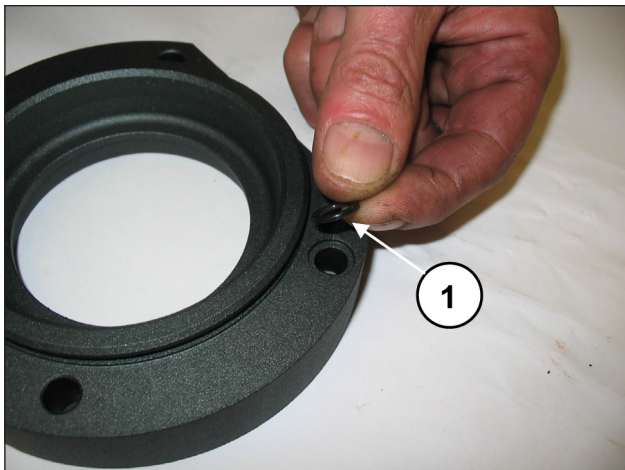

Fig. 66

Montar una de las tapas del cojinete PTO (derecha o izquierda) en el cárter de la bomba (pos. ①, Fig. 67) y fijarla con los 4 tornillos M8x30 (pos. ①, Fig. 68).



Prestar atención al sentido de montaje de la tapa. El orificio de lubricación de la tapa debe coincidir con el orificio del cárter.

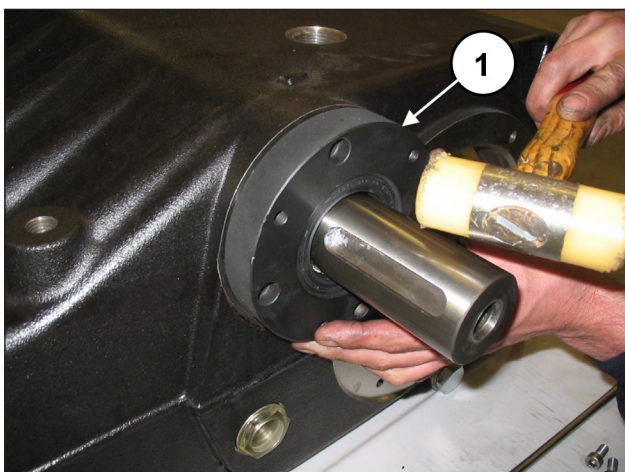

Fig. 67

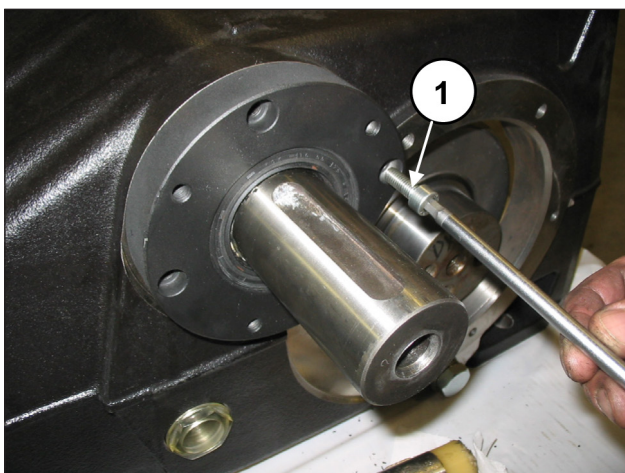

Fig. 68

Repetir las operaciones en el lado opuesto.
Introducir la anilla interna (pos. ①, Fig. 61) y la anilla externa (pos. ①, Fig. 62) del último cojinete.
Montar la segunda tapa del cojinete PTO en el cárter de la bomba (pos. ①, Fig. 67) y fijarla con los 4 tornillos M8x30 (pos. ①, Fig. 68).
Ajustar los 4+4 tornillos con la llave dinamométrica como se indica en el capítulo 3.

Pre montar las dos tapas portacojinete: insertar el cojinete utilizando una herramienta de percusión (pos. ①, Fig. 69) hasta obtener una cota de 4 - 4.5 mm como se indica en la Fig. 70.

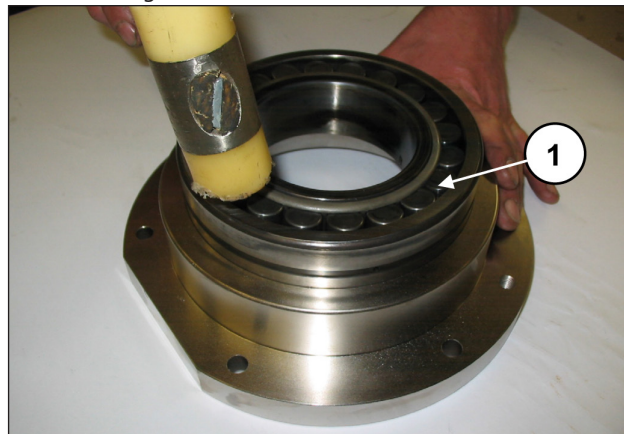

Fig. 69

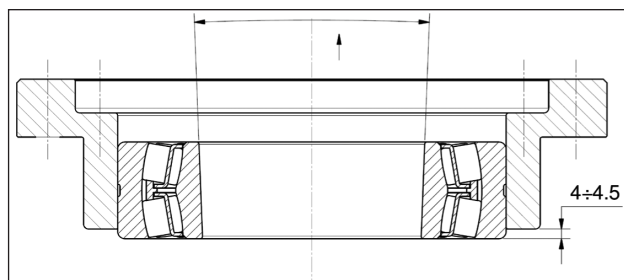

Fig. 70



El cojinete de la Fig. 70 posee una anilla interna cónica. Comprobar que tanto la parte interna como la externa de la anilla sean cónicas, para permitir la introducción del casquillo.

Aplicar la junta tórica en el extremo de la tapa portacojinete (pos. ①, Fig. 71).

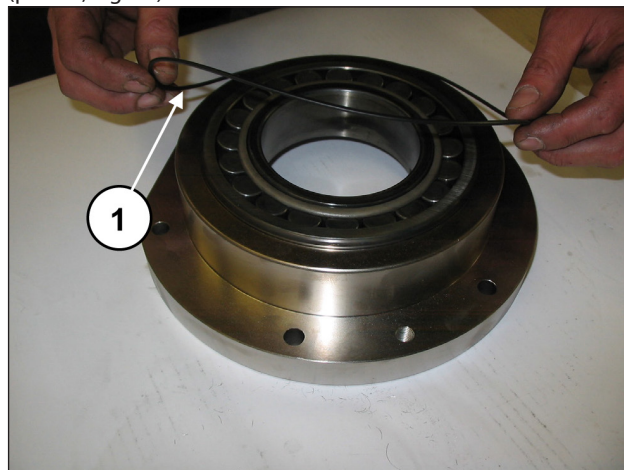

Fig. 71

Repetir la operación en la otra tapa.
Bloquear los tres grupos de biela con la herramienta cód. 27566200, (pos. ①, Fig. 40).

Aplicar los dos pernos roscados M16 en el extremo del eje acodado y, manteniéndolo levantado, (pos. ①, Fig. 72), introducir la tapa portacojinetes junto con la junta tórica (pos. ①, Fig. 73) utilizando la herramienta de percusión. Repetir la operación en el lado opuesto.

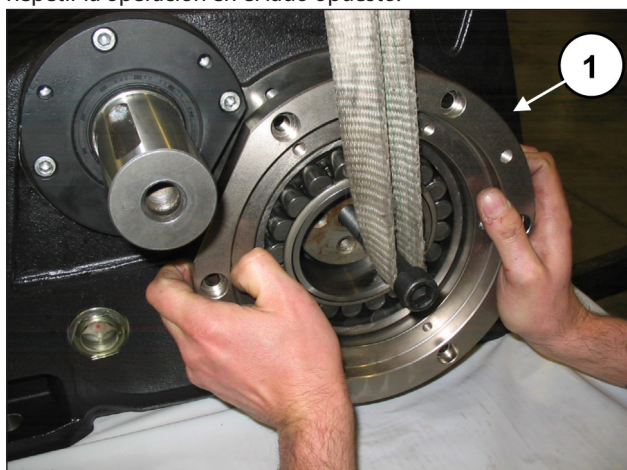

Fig. 72

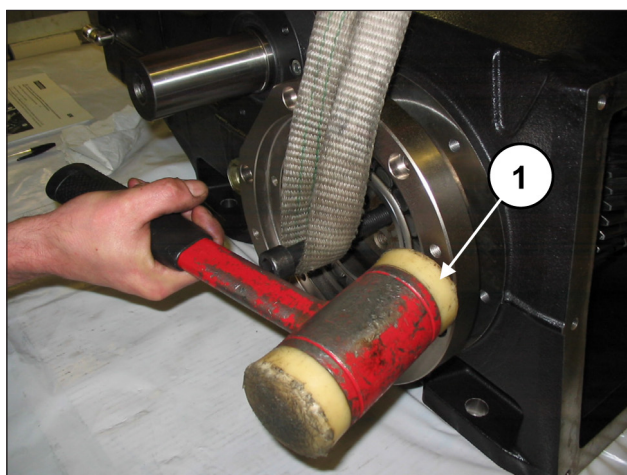

Fig. 73

Bloquear las tapas portacojinete con los 6+6 tornillos M10x30 (pos. ①, Fig. 74). Ajustar los tornillos con la llave dinamométrica como se indica en el capítulo 3.

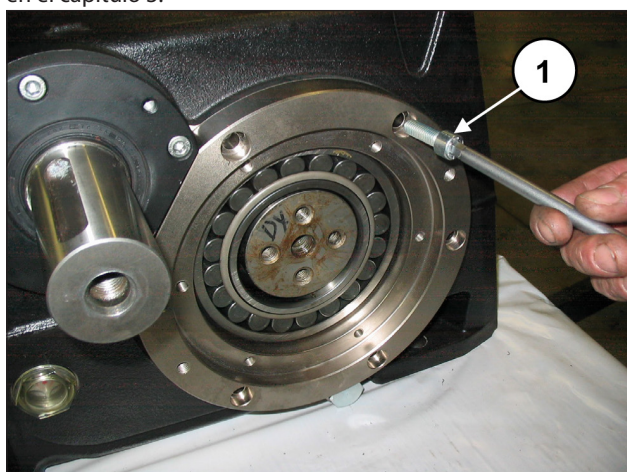

Fig. 74

Introducir parcialmente los dos casquillos de presión manteniendo el eje acodado levantado con el perno M16 montado anteriormente (pos. ①, Fig. 75).

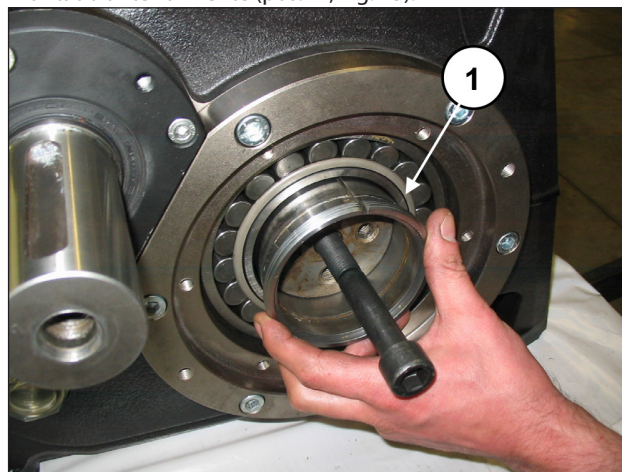

Fig. 75

Introducir a fondo el casquillo de presión en el eje acodado (pos. ①, Fig. 76 y Fig. 77) utilizando una herramienta de percusión y un tampón.

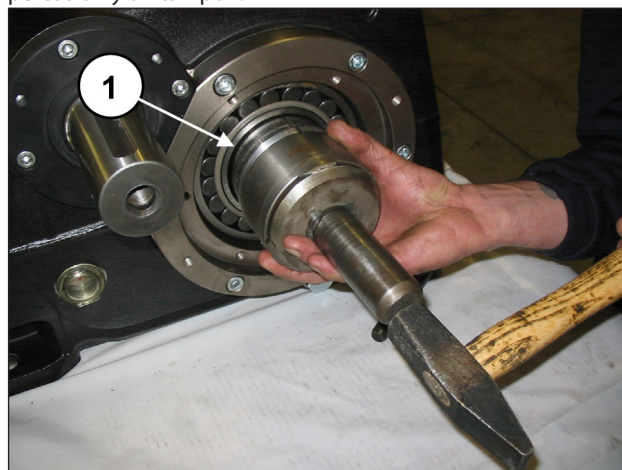

Fig. 76

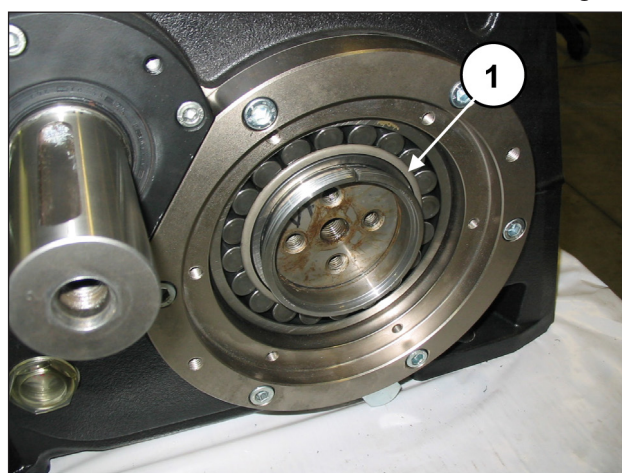

Fig. 77



El casquillo de presión se debe introducir en seco (sin aceites ni lubricantes).

Introducir el casquillo hasta que la superficie externa (cónica) acople perfectamente en la parte interna del cojinete. Durante la fase de introducción, comprobar que el cojinete permanezca en contacto con el tope del eje acodado. Repetir la operación en el lado opuesto.

Introducir las bridas de bloqueo del casquillo dentro de los casquillos cónicos (pos. ①, Fig. 78).
 Aplicar un tornillo M16 con la longitud adecuada (35-40 mm) en el orificio M16 del eje acodado y atornillarlo hasta que la brida se apoye en el casquillo (pos. ①, Fig. 79). **No apretar el tornillo.**

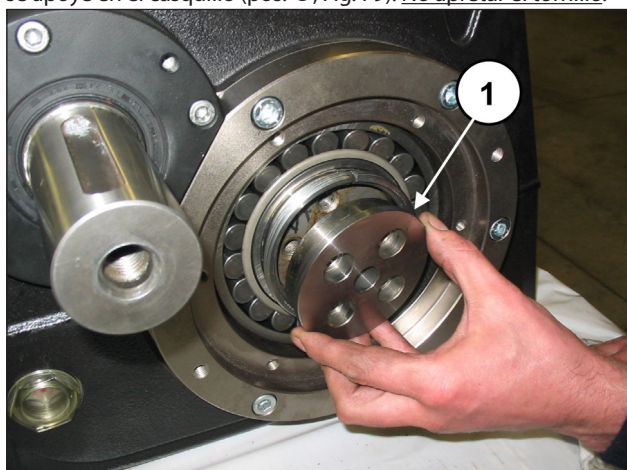

Fig. 78

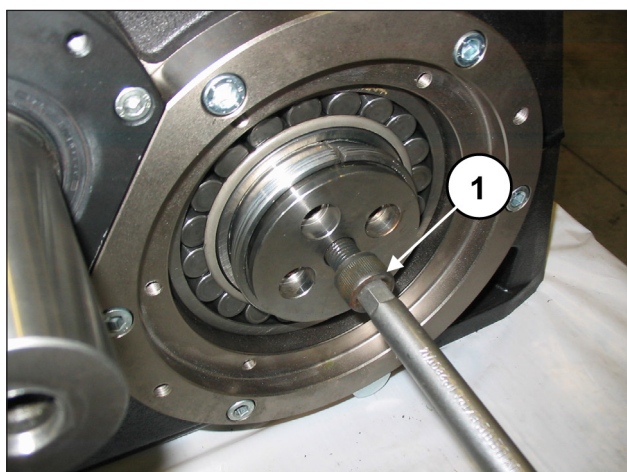

Fig. 79

Repetir la operación en el lado opuesto.
 Desmontar la herramienta que bloquea las bielas cód. 27566200, (pos. ①, Fig. 40).
 Introducir los semicojinetes superiores entre las bielas y el eje acodado (pos. ①, Fig. 80).

Para montar correctamente los cojinetes, la lengüeta de referencia de los semicojinetes debe encajar en el alojamiento de la semibiela (pos. ①, Fig. 81).

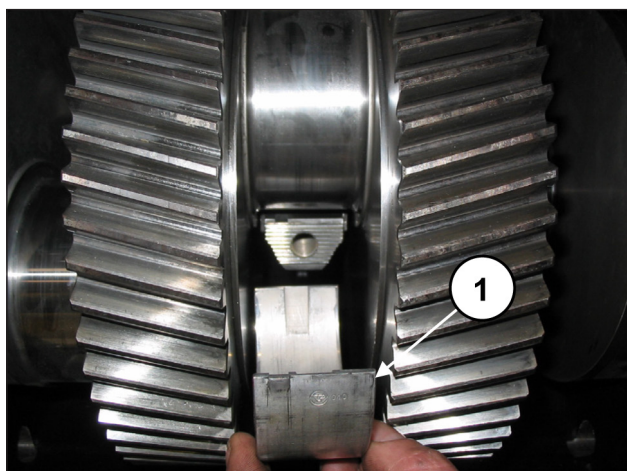

Fig. 80

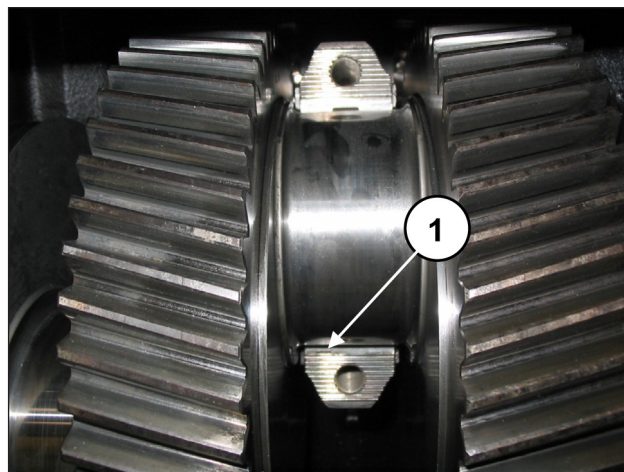

Fig. 81

Montar los semicojinetes inferiores en los sombreretes (pos. ①, Fig. 82). Comprobar que la lengüeta de referencia de los semicojinetes esté dentro del alojamiento del sombrerete (pos. ②, Fig. 82). Fijar los sombreretes a las semibielas con los tornillos M12x1.25x87 (pos. ①, Fig. 83).

Ajustar los tornillos con la llave dinamométrica como se indica en el capítulo 3, aplicando el par de apriete a los tornillos de manera simultánea.



Prestar atención al sentido correcto de montaje de los sombreretes. La numeración debe estar orientada hacia arriba.

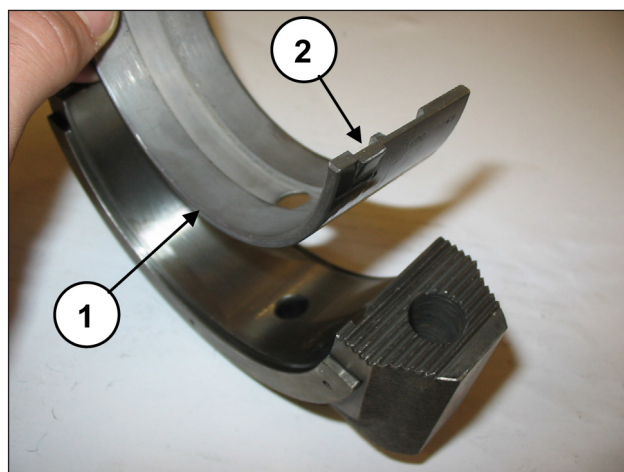

Fig. 82

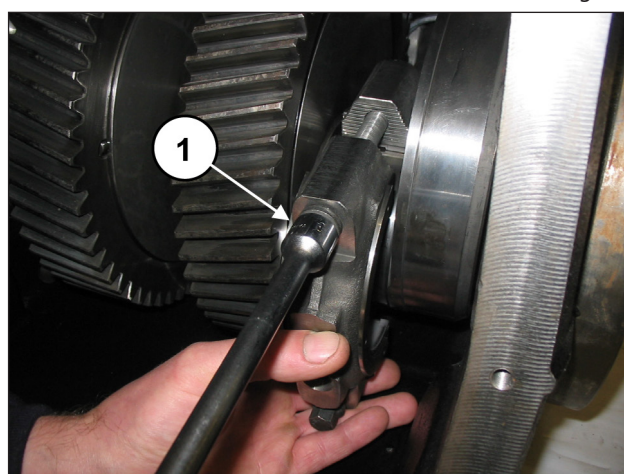

Fig. 83



Ad terminar las operaciones, comprobar la holgura axial de las bielas en ambas direcciones.

Introducir un espesor debajo del cilindro de la biela central para bloquear la rotación del eje acodado (pos. ①, Fig. 84).

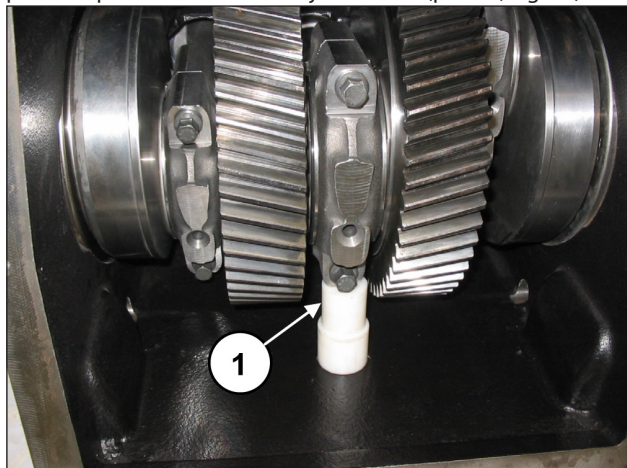

Fig. 84

Medir la cota "X" indicada en la Fig. 85 entre el casquillo cónico y el cojinete del eje acodado.

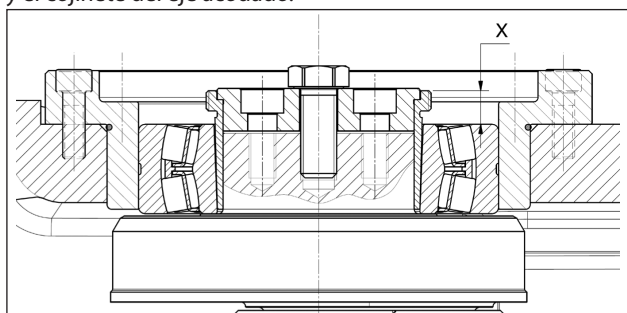

Fig. 85

Apretar el tornillo M16 hasta obtener una reducción de la cota "X" entre 0,7 y 0,8 mm (Fig. 86).

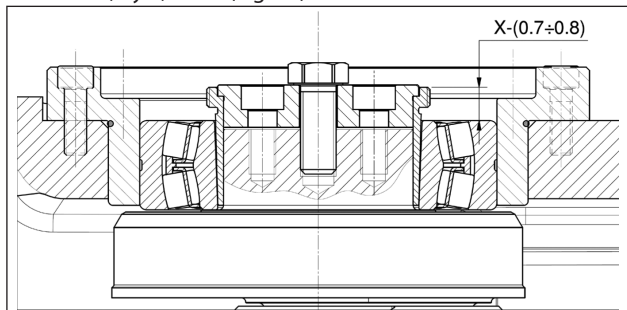

Fig. 86

Repetir la operación en el lado opuesto.
Extraer el tornillo M16 del eje acodado.
Fijar las dos bridas que bloquean el casquillo al eje acodado con 4+4 tornillo M12x25 (pos. ①, Fig. 88).



Aplicar LOCTITE 243 a las roscas de los tornillos M12x25 (pos. ①, Fig. 87).

Ajustar los tornillos con la llave dinamométrica como se indica en el capítulo 3.

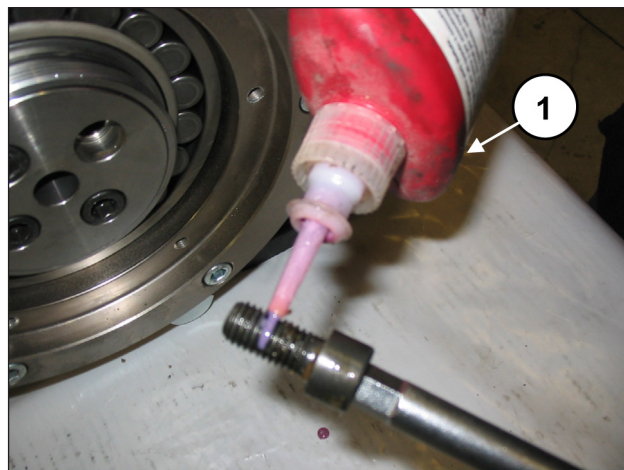

Fig. 87

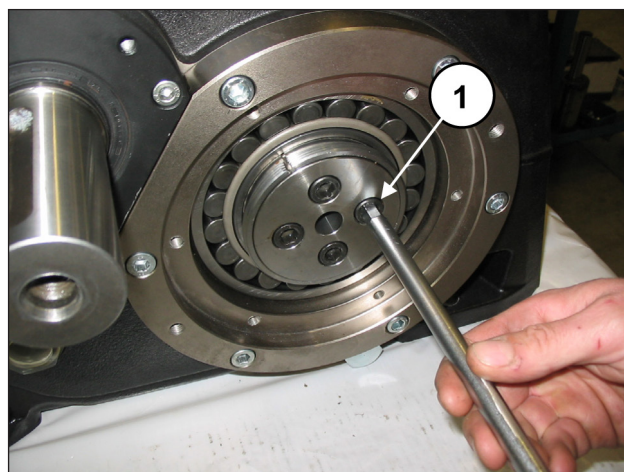

Fig. 88

Quitar el espesor anti-rotación que hay debajo del cilindro de la biela central.

Montar las dos tapas del cojinete junto con las juntas tóricas (pos. ①, Fig. 89) y fijarlas con los 6+6 tornillos M8x20 (pos. ①, Fig. 90).

Ajustar los tornillos con la llave dinamométrica como se indica en el capítulo 3.

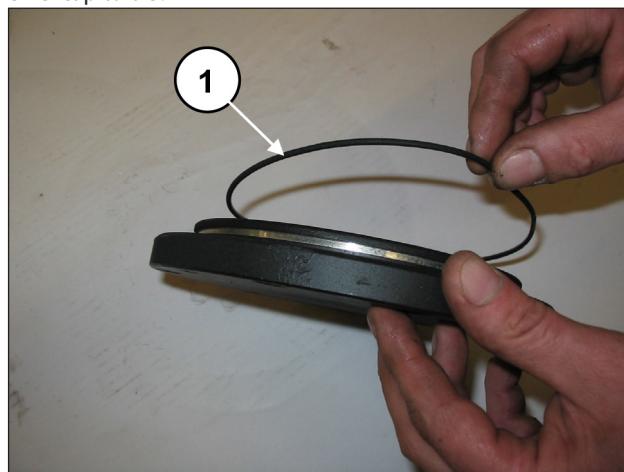

Fig. 89

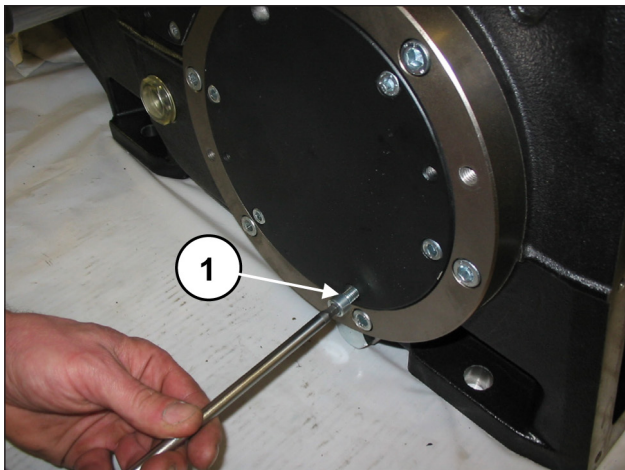

Fig. 90

Introducir la junta tórica en la tapa posterior (pos. ①, Fig. 91) y fijarla al cárter con los 10 tornillos M8x20 (pos. ①, Fig. 92). Ajustar los tornillos con la llave dinamométrica como se indica en el capítulo 3.

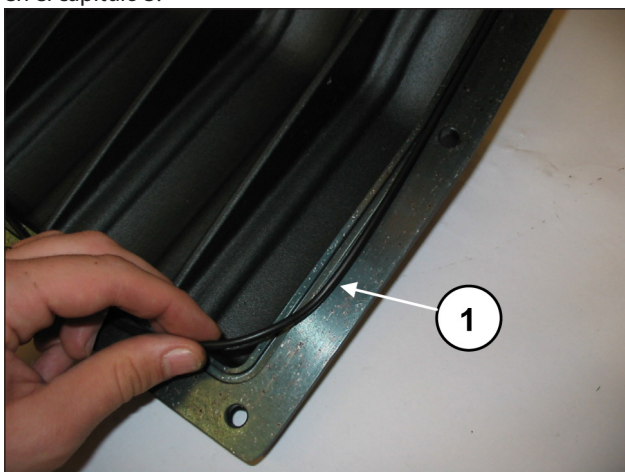

Fig. 91

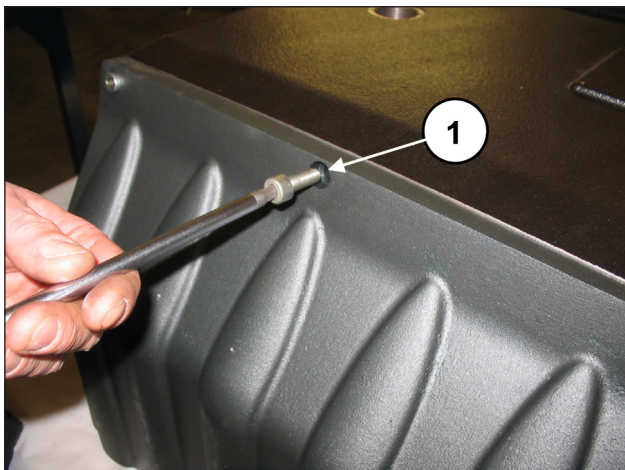

Fig. 92

Montar la anilla de retención radial en la tapa de retención (pos. ①, Fig. 93) utilizando un tampón cód. 27910900.

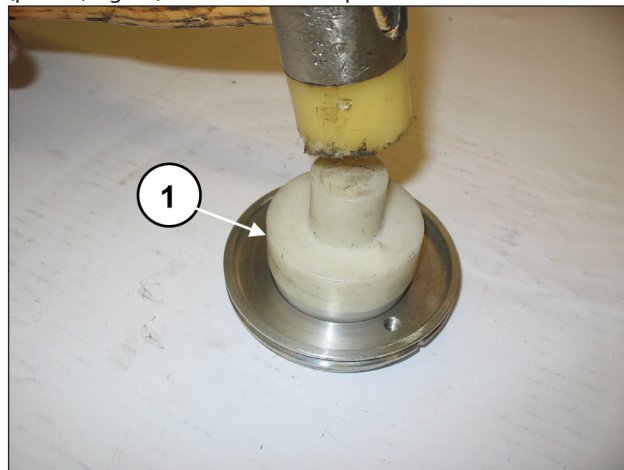

Fig. 93

Colocar la junta tórica (pos. ①, Fig. 94) en el alojamiento de la tapa de retención.

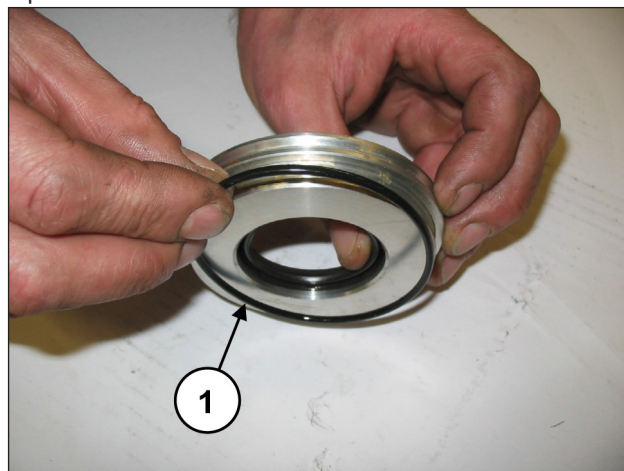

Fig. 94

Introducir el grupo montado dentro del cárter en el alojamiento y comprobar que la tapa encaje a fondo (pos. ①, Fig. 95), sin dañar el labio de la anilla de retención radial. Fijar las tapas de retención con 2 tornillos prisioneros M6x30 (pos. ①, Fig. 96).

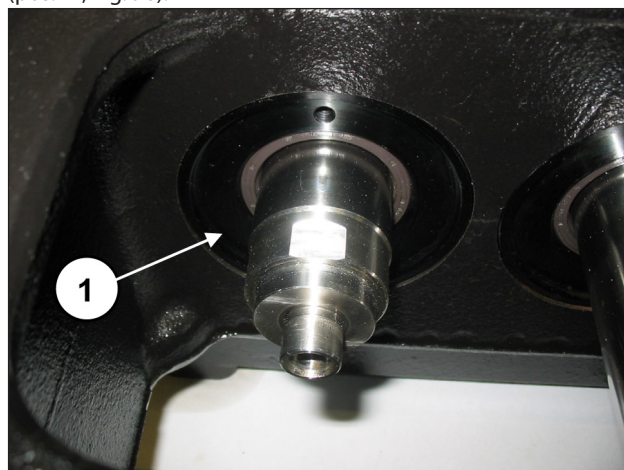

Fig. 95

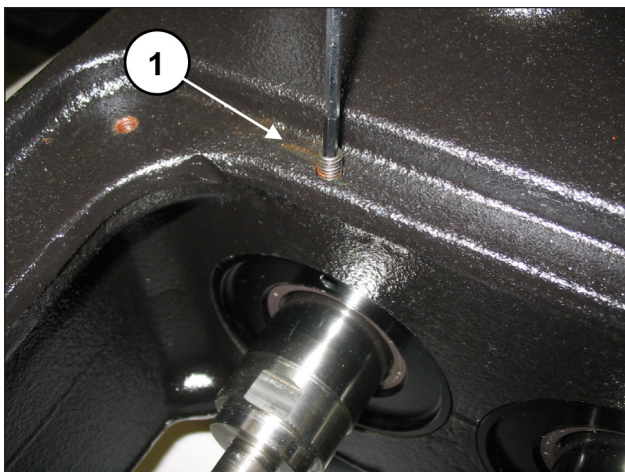

Fig. 96

Ajustar los tornillos con la llave dinamométrica como se indica en el capítulo 3.

Colocar la protección contra salpicaduras y la anilla distanciadora en el alojamiento sobre el vástago de guía del pistón (pos. ①, Fig. 97 y Fig. 98).

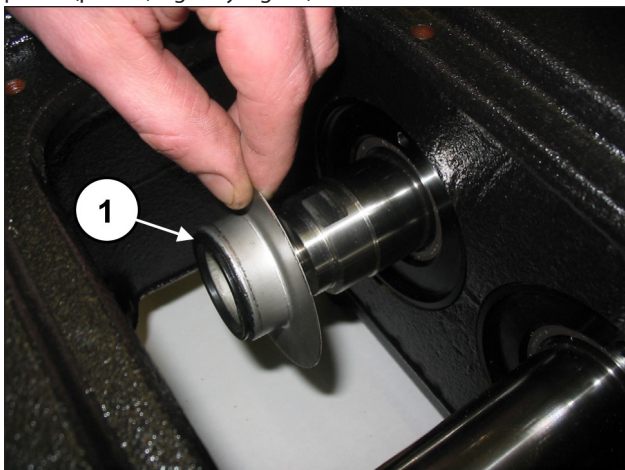

Fig. 97

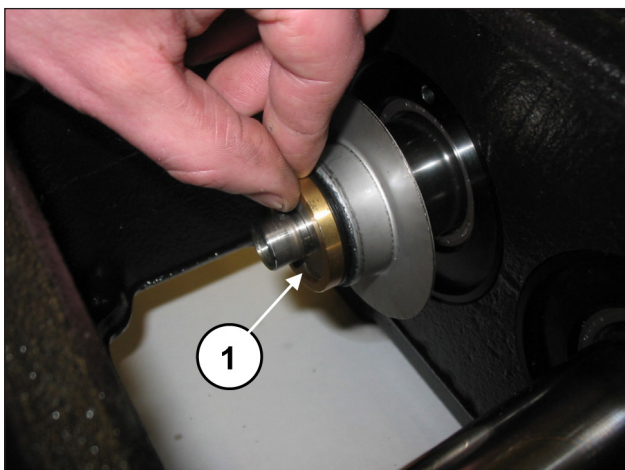

Fig. 98

Introducir la junta tórica (pos. ①, Fig. 99) en las tapas de inspección y montar las tapas con 4+4 tornillos M6x14 (pos. ①, Fig. 100).

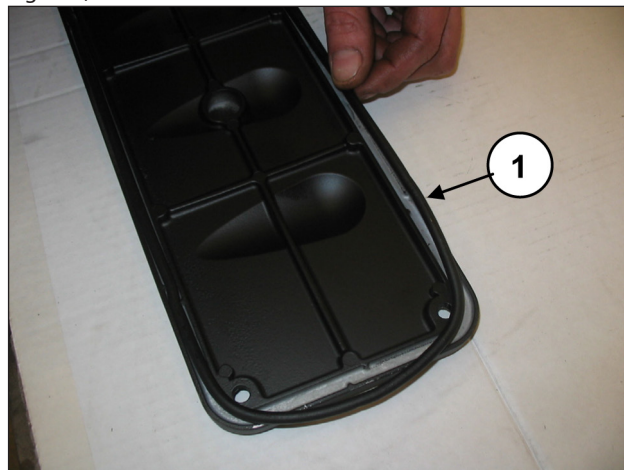

Fig. 99

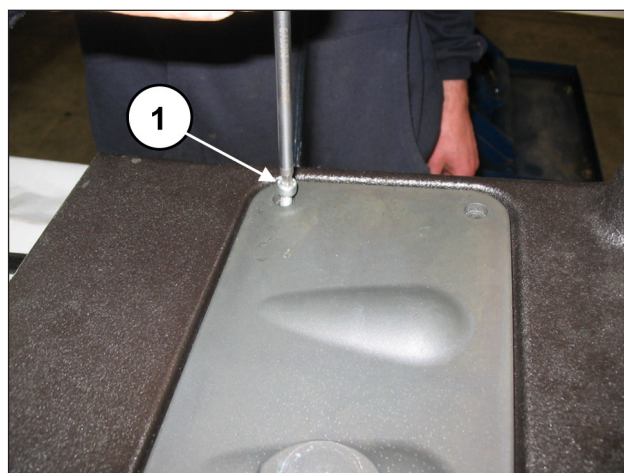

Fig. 100

Ajustar los tornillos con la llave dinamométrica como se indica en el capítulo 3 "Calibración de ajuste de los tornillos".

Montar la tapa del extremo del eje y fijarla al cárter con los 3 tornillos M8x20 (pos. ①, Fig. 101).

Ajustar los tornillos con la llave dinamométrica como se indica en el capítulo 3 "Calibración de ajuste de los tornillos".



Fig. 101

Introducir la lengüeta en el eje PTO (pos. ①, Fig. 102).

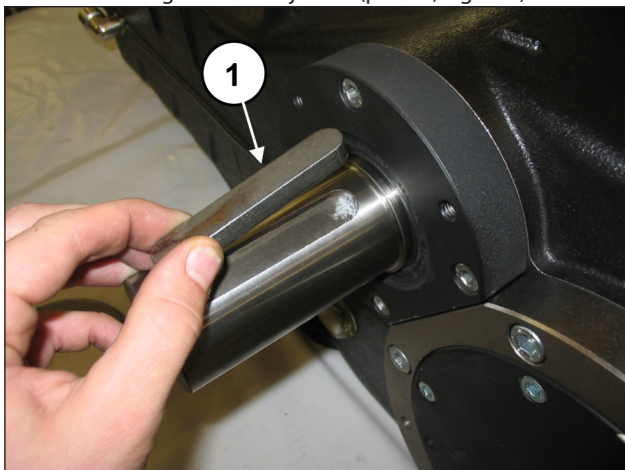

Fig. 102

2.1.3 Clases de mayoraciones previstas

TABLA DE MAYORACIONES PARA EJE ACODADO Y SEMICOJINETES DE LA BIELA			
Clases de recuperación (mm)	Código semicojinete superior	Código semicojinete inferior	Rectificación sobre el diámetro del perno del eje (mm)
0.25	90931100	90930100	Ø92.75 0/-0.03 Ra 0.4 Rt 3.5
0.50	90931200	90930200	Ø92.50 0/-0.03 Ra 0.4 Rt 3.5

TABLA DE MAYORACIONES PARA CÁRTER DE LA BOMBA Y GUÍA DEL PISTÓN		
Clases de recuperación (mm)	Código de la guía pistón	Rectificación en alojamiento del cárter de la bomba (mm)
1.00	79050543	Ø81 H6 +0.022/0 Ra 0.8 Rt 6

2.2 REPARACIÓN DE LA PARTE HIDRÁULICA

2.2.1 Desmontaje de la cabeza - grupos de válvulas

La cabeza requiere mantenimiento preventivo como se indica en el **Manual de uso y mantenimiento**.

Las intervenciones se limitan a la inspección o sustitución de las válvulas, en el caso que sea necesario:

Para extraer los grupos de válvula operar del siguiente modo: Desenroscar el dispositivo de apertura de las válvulas con una llave de 30 mm (pos. ①, Fig. 103).

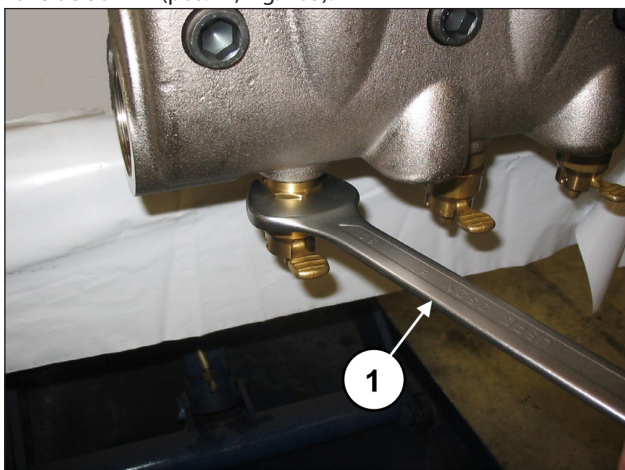

Fig. 103

Aplicar dos soportes con rosca G2" en las conexiones de envío de la cabeza (pos. ①, Fig. 104) y, a continuación, apretar los 8 tornillos M16x150 (pos. ①, Fig. 105).

No golpear los pistones al extraer la cabeza.

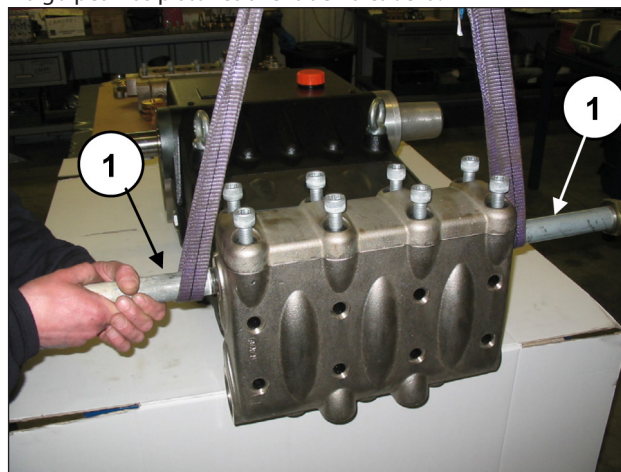

Fig. 104

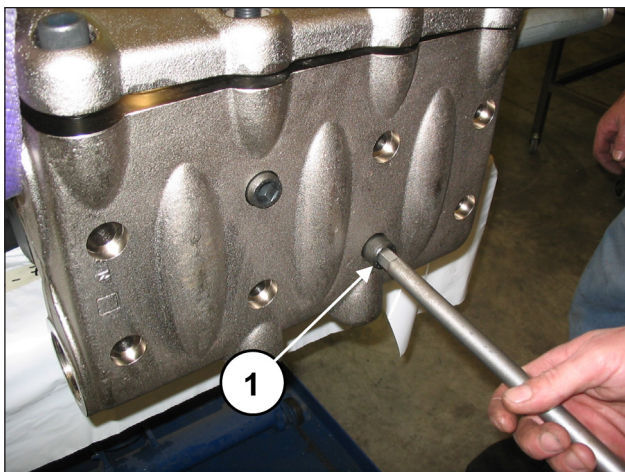

Fig. 105

Extraer los 8 tornillos M16x55 de la tapa de válvulas (pos. ①, Fig. 106) y desmontar la tapa (pos. ①, Fig. 107).

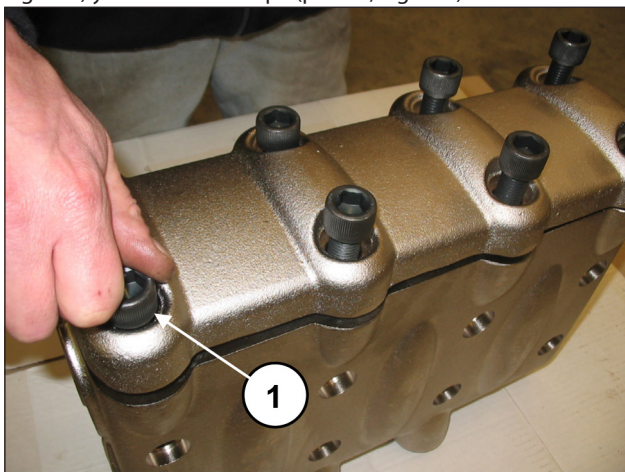

Fig. 106

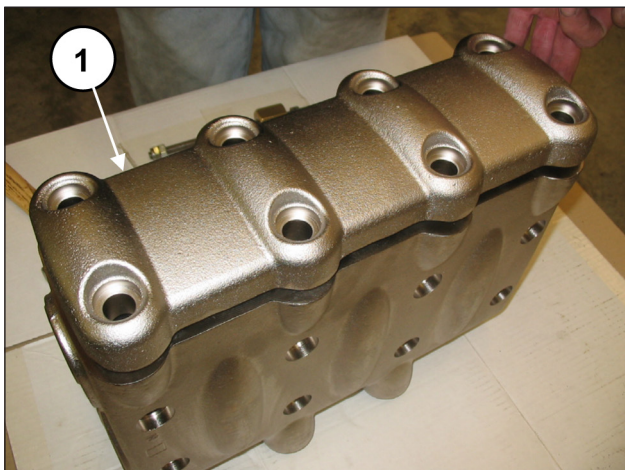

Fig. 107

Extraer el tapón de la válvula introduciendo un extractor de percusión en el orificio M10 del tapón de la válvula (pos. ①, Fig. 108).

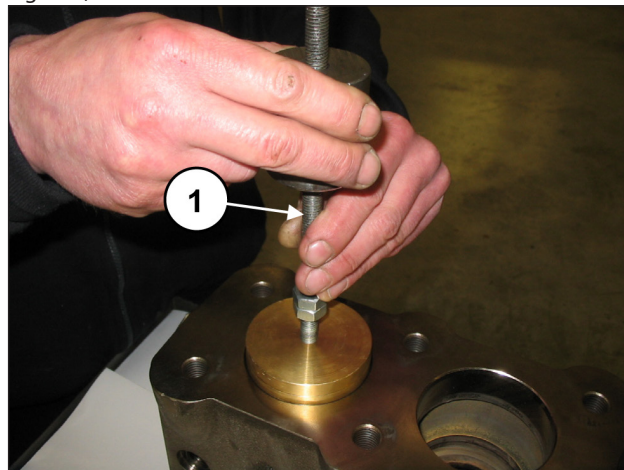

Fig. 108

Extraer el muelle (pos. ①, Fig. 109).

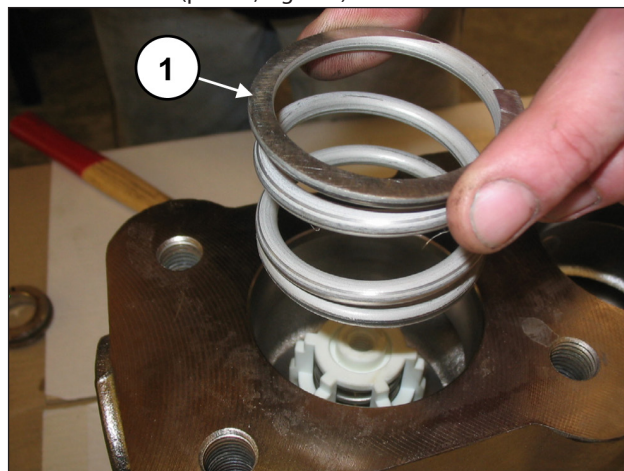

Fig. 109

Extraer el grupo de la válvula de envío introduciendo un extractor de percusión en el orificio M10 de la guía de la válvula (pos. ①, Fig. 110).

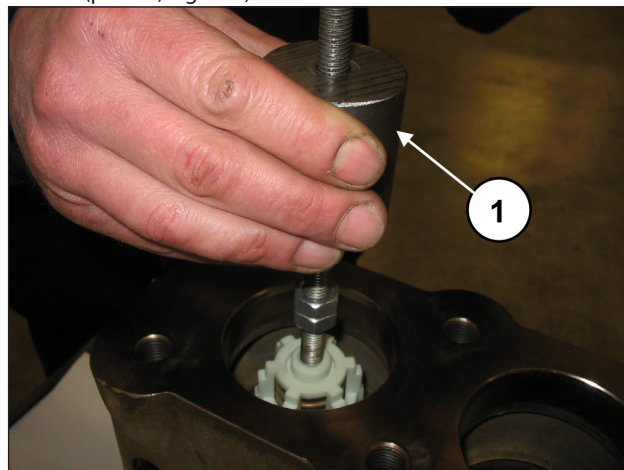

Fig. 110



En caso de dificultad para extraer el grupo de la válvula de envío (por ejemplo, si se han formado depósitos debidos a largos periodos de inactividad de la bomba) utilizar el extractor cód. 27516400.

Extraer el distanciador de la guía de la válvula utilizando una llave hexagonal de 8 mm (pos. ①, Fig. 111).

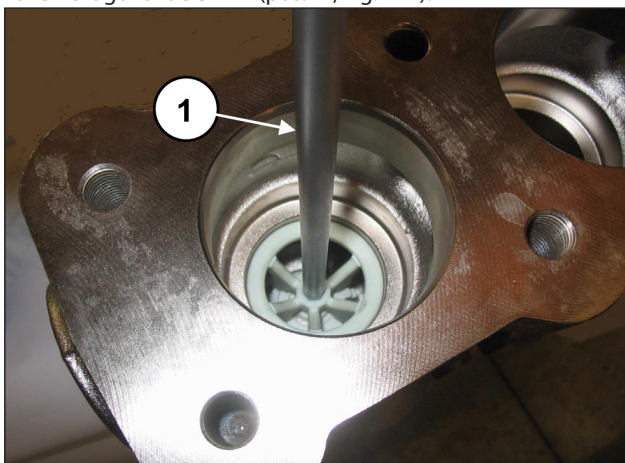

Fig. 111

Extraer el grupo de la válvula de aspiración introduciendo un extractor de percusión en el orificio M10 de la guía de la válvula (pos. ①, Fig. 112).

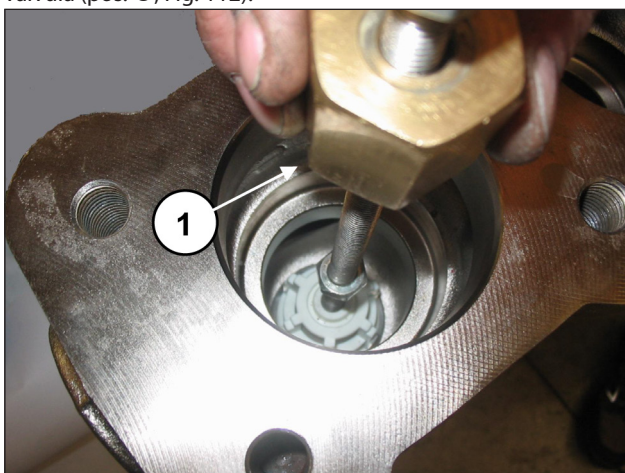

Fig. 112



En caso de dificultad para extraer el grupo de la válvula de aspiración (por ejemplo, si se han formado depósitos debidos a largos periodos de inactividad de la bomba) utilizar el extractor cód. 27516200 (para LK36-LK40-LK45) o cód. 27516300 (para LK50-LK55-LK60) (pos. ①, Fig. 113) y actuar como se indica a continuación.

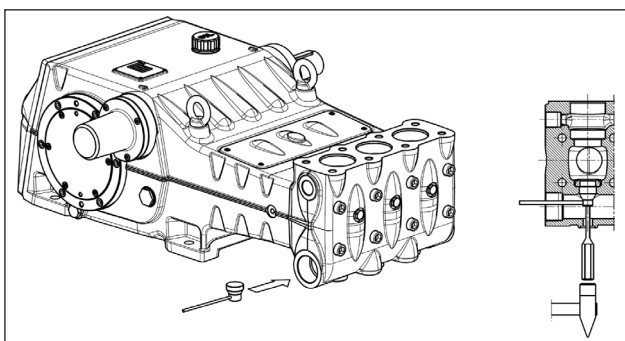

Fig. 113

Desmontar los grupos de las válvulas de aspiración y envío atornillando un tornillo M10 para presionar la guía interna y extraer la guía de la válvula de la sede (pos. ①, Fig. 114).

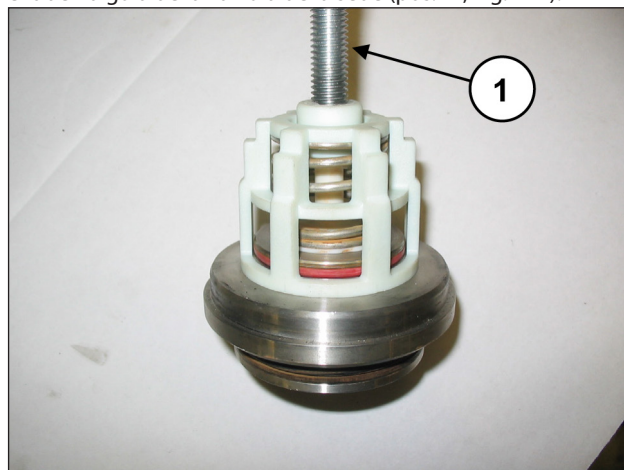

Fig. 114

2.2.2 Montaje de cabeza – grupos de válvulas

Controlar el desgaste de los componentes y sustituirlos si es necesario.



A cada inspección de las válvulas, sustituir todas las juntas tóricas sea de los grupos que de los tapones de válvula.



Antes de volver a colocar los grupos de válvula, limpiar y secar perfectamente los correspondientes alojamientos en la cabeza tal y como indican las flechas (pos. ①, Fig. 115).

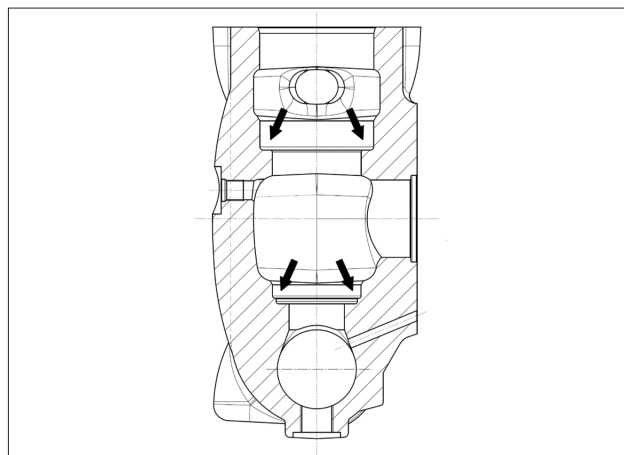

Fig. 115

Seguir en orden contrario la secuencia de desmontaje descrita en el apart. 2.2.1.

Ensamblar los grupos de las válvulas de aspiración y envío (Fig. 116 y Fig. 117) sin invertir los muelles desmontados anteriormente.

Para facilitar la introducción de la guía de la válvula en su sede se puede utilizar un tubo que apoye sobre los pisos horizontales de la guía (Fig. 118) y utilizar un martillo de timbre actuando sobre toda la circunferencia.



Fig. 116

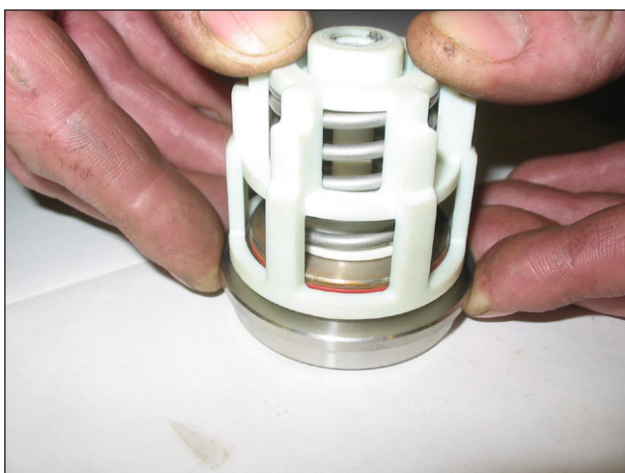

Fig. 117

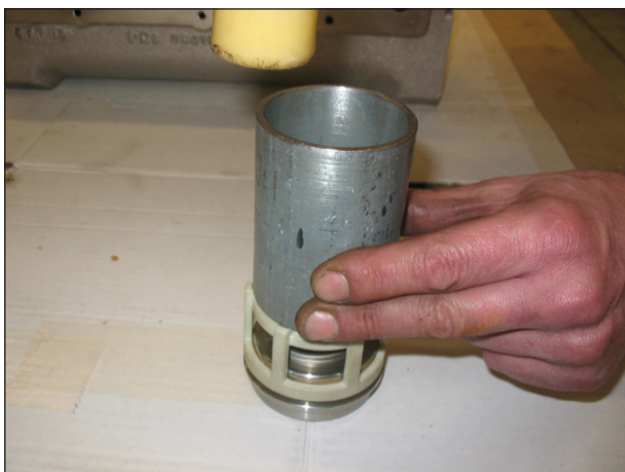

Fig. 118



Introducir los grupos de las válvulas de aspiración y envío en la cabeza, controlando la secuencia de introducción de las juntas tóricas y de las anillas anti extrusión.

La secuencia correcta de montaje de los grupos de válvulas en la cabeza es la siguiente:

Introducir la anilla anti extrusión, pos. dibujo desglosado 4 (pos. ①, Fig. 119).

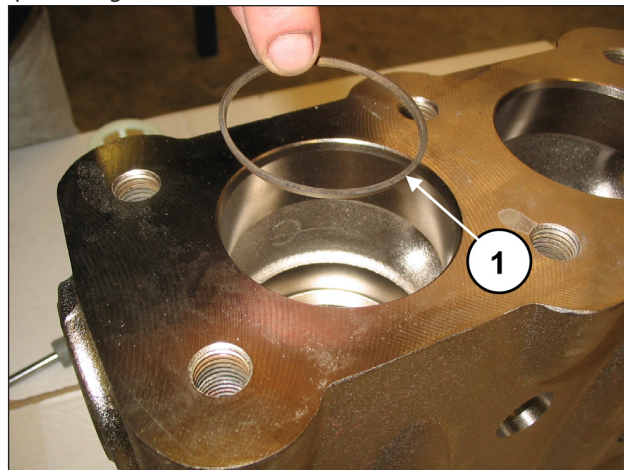

Fig. 119

Introducir la junta tórica, pos. dibujo desglosado 5 (pos. ①, Fig. 120).

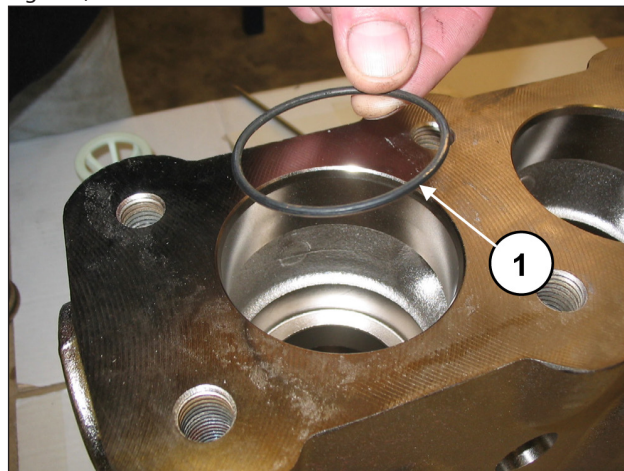

Fig. 120

Comprobar que la junta tórica y la anilla anti extrusión estén colocadas de manera correcta en el alojamiento.

Introducir el grupo de la válvula de aspiración (pos. ①, Fig. 121) y, a continuación, el distanciador (pos. ①, Fig. 122). El grupo de la válvula se ha de introducir a fondo como se indica en la pos. ①, Fig. 122.

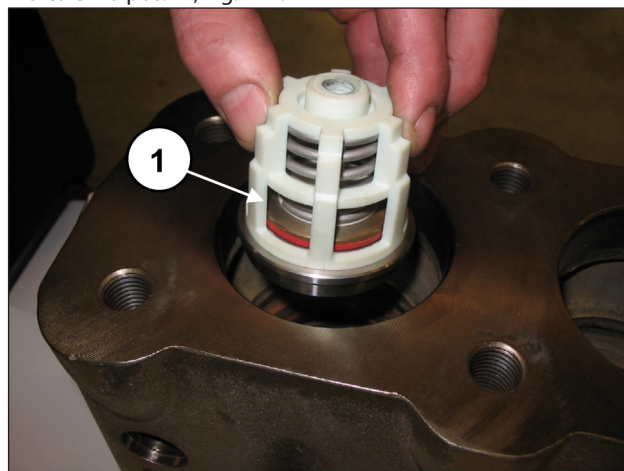

Fig. 121

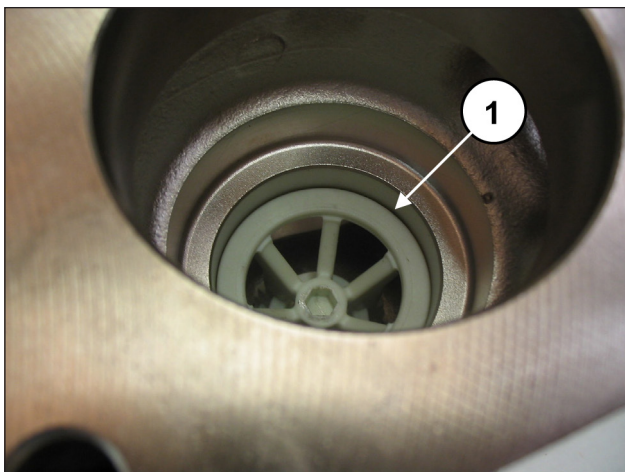

Fig. 122

Montar la junta tórica, pos. dibujo desglosado 5 (pos. ①, Fig. 123) y la anilla anti extrusión pos. desglosado 15 (pos. ②, Fig. 123) en la sede de la válvula de envío.

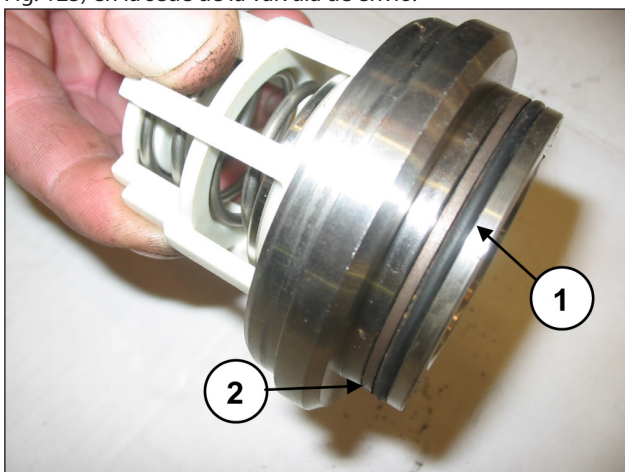

Fig. 123

Introducir el grupo de la válvula de envío (pos. ①, Fig. 124). El grupo de la válvula se ha de introducir a fondo como se indica en la pos. ①, Fig. 125.

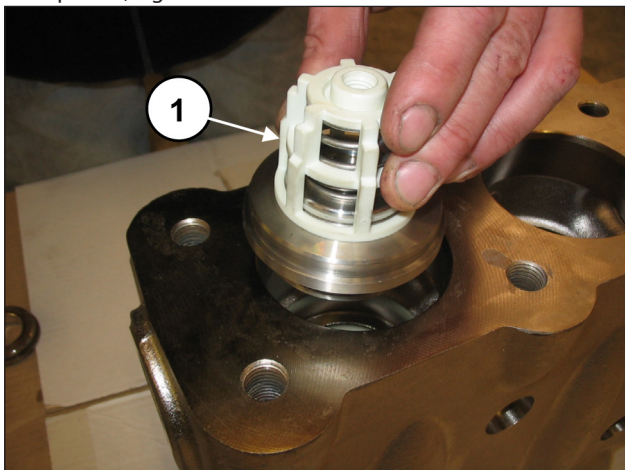

Fig. 124

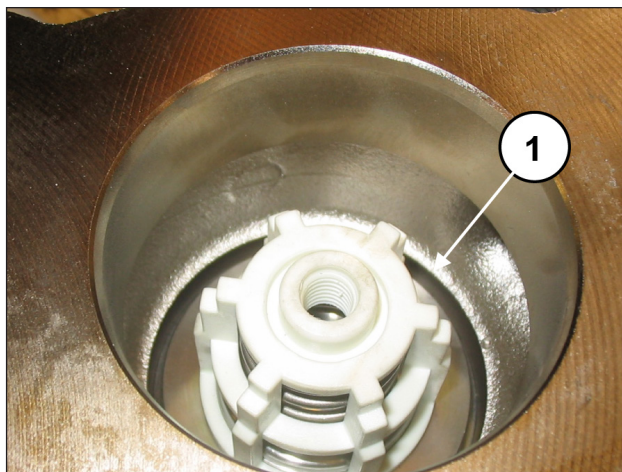

Fig. 125

Introducir la anilla anti extrusión, pos. dibujo desglosado 16 (pos. ①, Fig. 126).

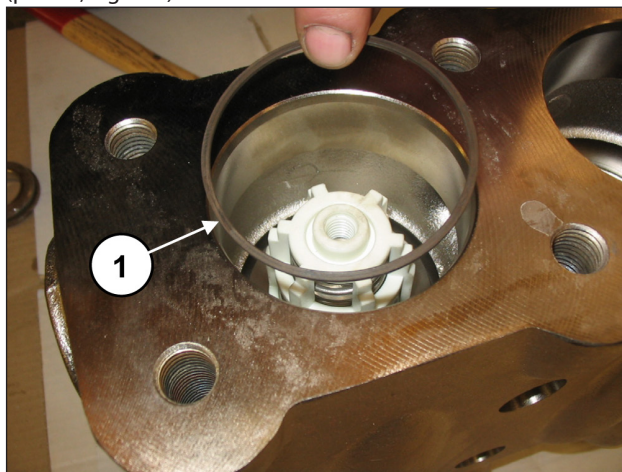

Fig. 126

Introducir la junta tórica, pos. dibujo desglosado 17 (pos. ①, Fig. 127).

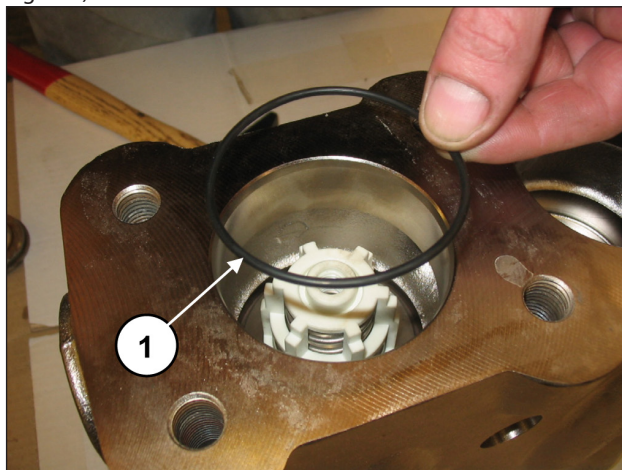

Fig. 127



Introducir con atención la junta tórica indicada en la pos. ①, Fig. 128.
Se recomienda utilizar la herramienta cód. 27516000 (para LK36-LK40-LK45) o cód. 27516100 (para LK50-LK55-LK60) para no cortar la junta tórica al introducirla.

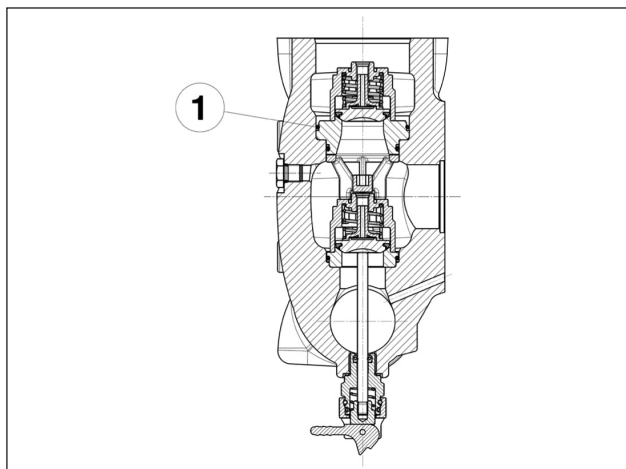

Fig. 128

Introducir la anilla del alojamiento de la válvula (pos. ①, Fig. 129) y el muelle (pos. ①, Fig. 130).

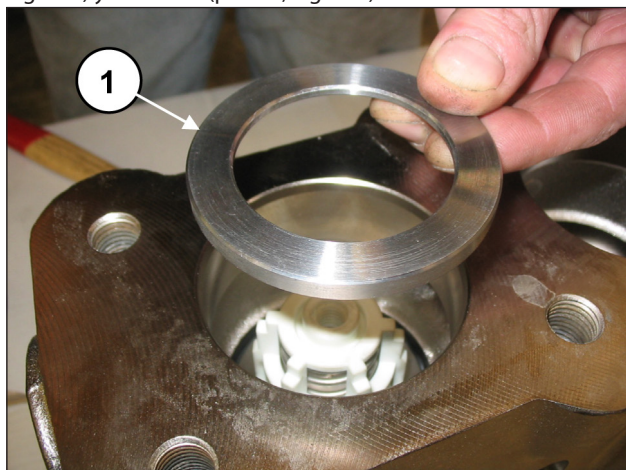

Fig. 129

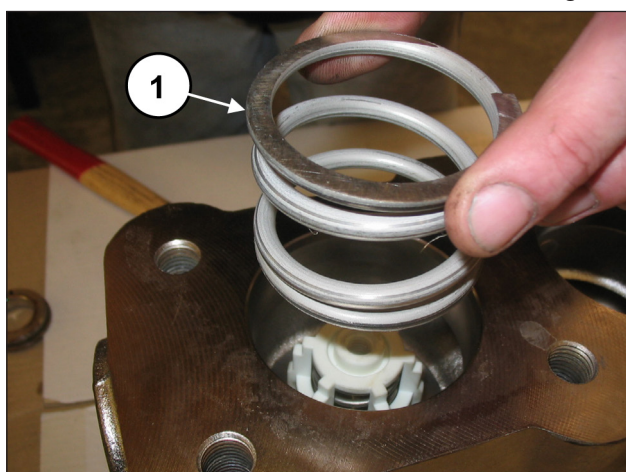

Fig. 130

Montar la junta tórica, pos. dibujo desglosado 17 (pos. ①, Fig. 131) y la anilla anti extrusión pos. desglosado 21 (pos. ②, Fig. 131) en el tapón de la válvula de envío.

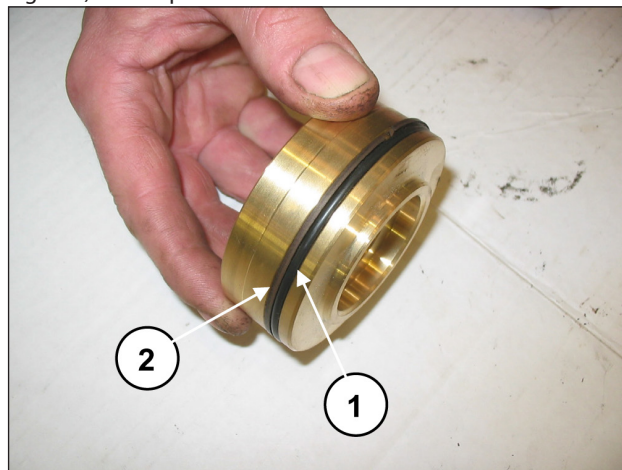

Fig. 131

Introducir el tapón de la válvula con la junta tórica y las anillas anti extrusión.

Al terminar de montar los grupos y el tapón de la válvula, aplicar la tapa de las válvulas (pos. ①, Fig. 132) y apretar los 8 tornillos M16x55 (pos. ①, Fig. 133).

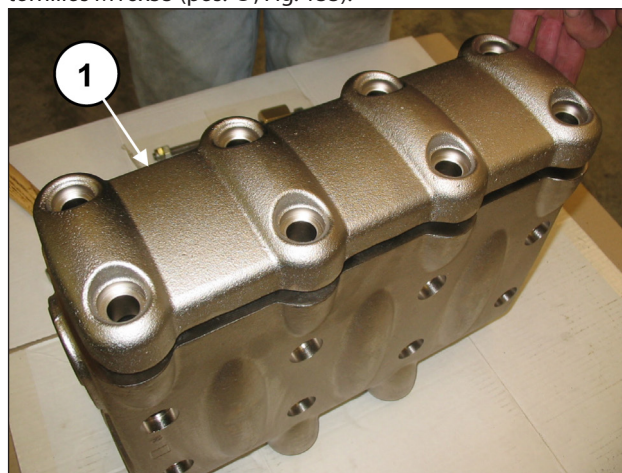

Fig. 132

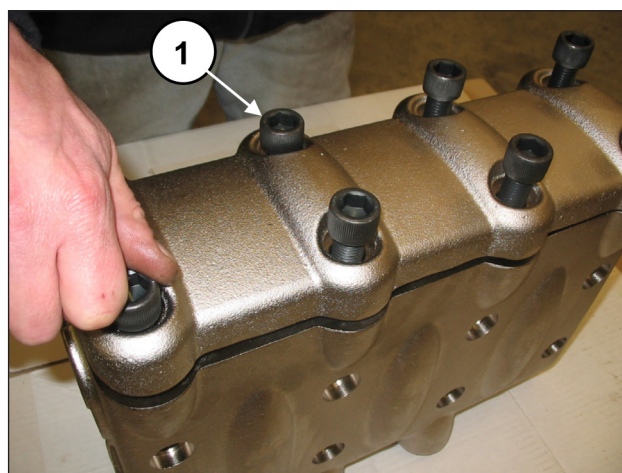

Fig. 133

Montar la cabeza en el cárter de la bomba (pos. ①, Fig. 134) sin golpear los pistones y apretar los 8 tornillos M16x150 (pos. ①, Fig. 135).

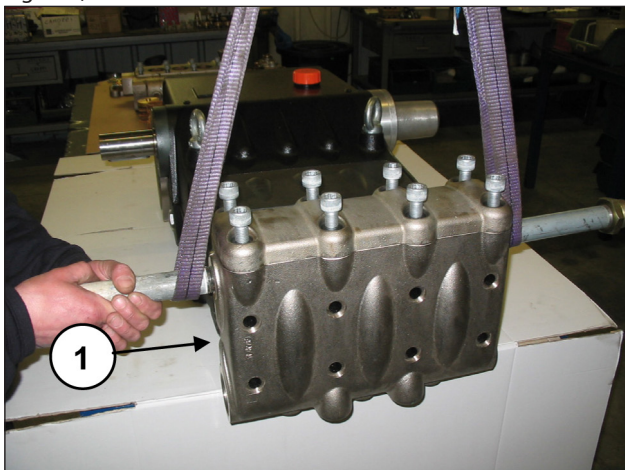

Fig. 134

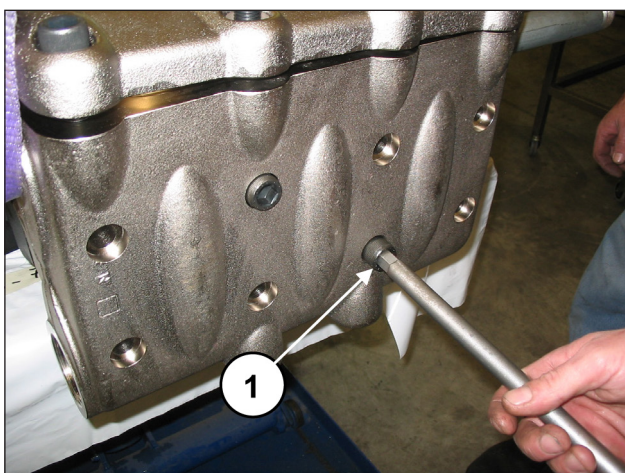

Fig. 135

Ajustar los tornillos M16x150 con la llave dinamométrica como se indica en el capítulo 3 "Calibración de ajuste de los tornillos".



Apretar en diagonal los 4 tornillos M16x150 internos (ver Fig. 135) y a continuación los 4 externos.

Ajustar los tornillos M16x55 de la tapa con la llave dinamométrica como se indica en el capítulo 3 "Calibración de ajuste de los tornillos".

Aplicar los dispositivos de apertura de las válvulas (pos. ①, Fig. 136) y enroscarlos con la llave de 30 mm (pos. ①, Fig. 137).

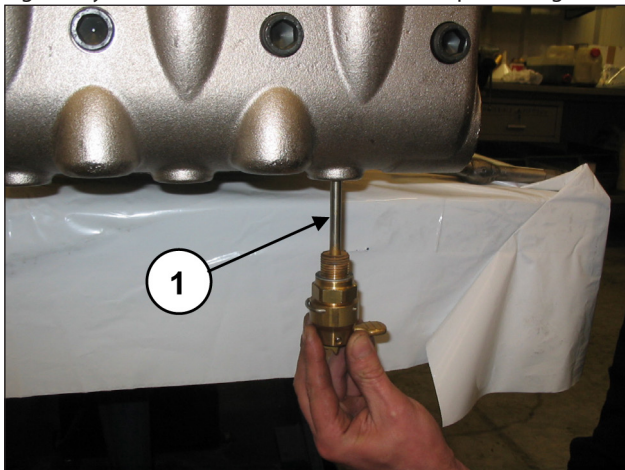

Fig. 136

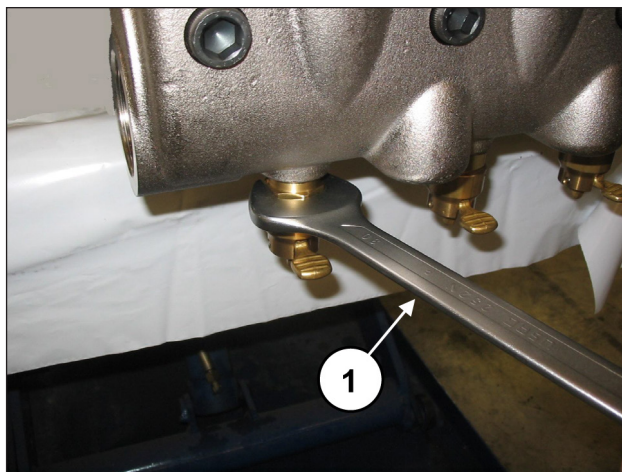

Fig. 137

2.2.3 Desmontaje del grupo pistón - soportes - juntas

Controlar el grupo del pistón de manera periódica como se indica en la tabla de mantenimiento preventivo del **Manual de uso y mantenimiento**.

Controlar de manera visual el drenaje del orificio de la tapa inferior. Si se detectan anomalías y oscilaciones en el manómetro de envío o pérdidas por el orificio de drenaje, controlar y sustituir el paquete de juntas.

Para extraer los grupos de pistón operar del siguiente modo: Para acceder al grupo de pistón, es necesario aflojar los tornillos M16x150 y desmontar la cabeza.



Extraer la cabeza con cuidado para no golpear los pistones.

Desmontar los pistones aflojando los tornillos de fijación (pos. ①, Fig. 138).

Extraer el pistón del soporte de juntas y comprobar que su superficie no esté rayada ni presente signos de desgaste o cavitación.

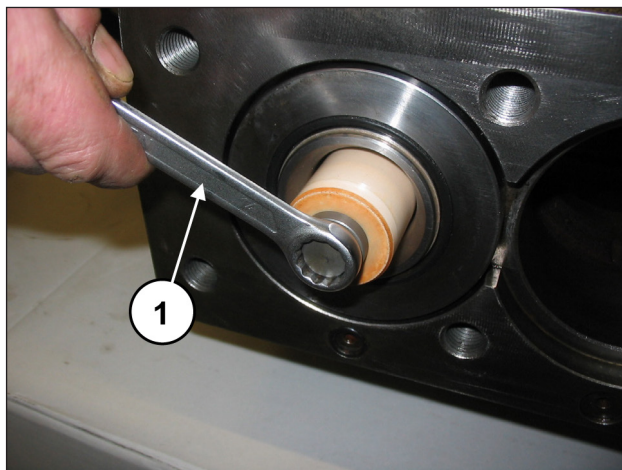

Fig. 138

Desmontar las tapas de inspección superior (pos. ①, Fig. 139) e inferior (pos. ①, Fig. 140) aflojando los 4+4 tornillos de fijación.

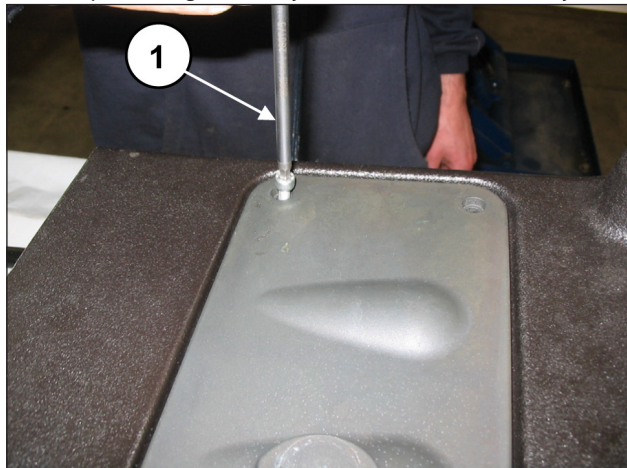

Fig. 139

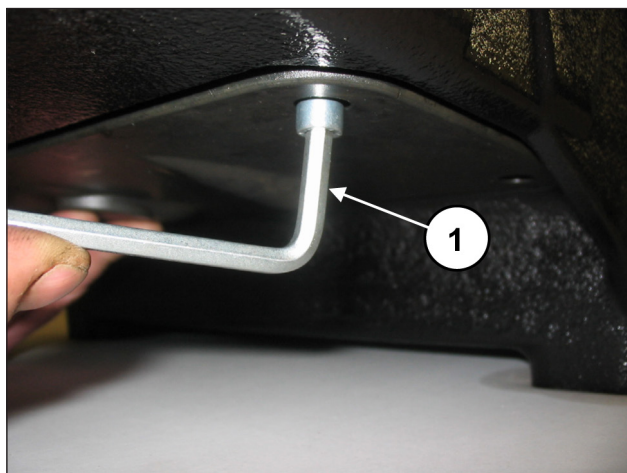

Fig. 140

Girar a mano el eje para situar los 3 pistones en el punto muerto superior.
Introducir la herramienta tampón (cód. 27516600 entre la guía del pistón y el pistón (pos. ①, Fig. 141).

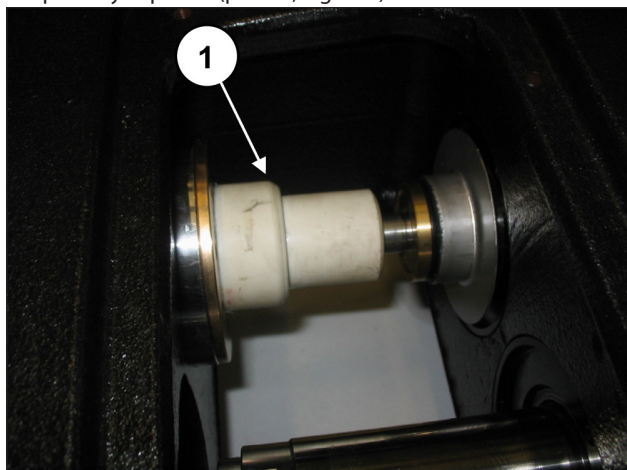

Fig. 141

Girar el eje para desplazar la guía del pistón de manera que el tampón avance y expulse el soporte de las juntas y el grupo del pistón completo (pos. ①, Fig. 142).



Fig. 142

Extraer el grupo de soporte de las juntas y la herramienta tampón.

Extraer de las guías de los pistones las anillas distanciadoras de protección contra las salpicaduras (pos. ①, Fig. 143) y las protecciones contra las salpicaduras (pos. ①, Fig. 144).

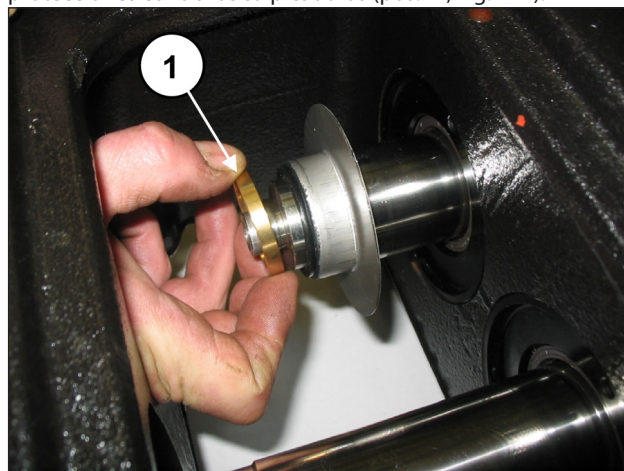

Fig. 143



Fig. 144

Separar el soporte de las juntas de la leva utilizando una llave de compás con pivotes redondos Ø5, a la venta en tiendas, (pos. ①, Fig. 145) y desenroscar el soporte hasta extraerlo (pos. ①, Fig. 146).

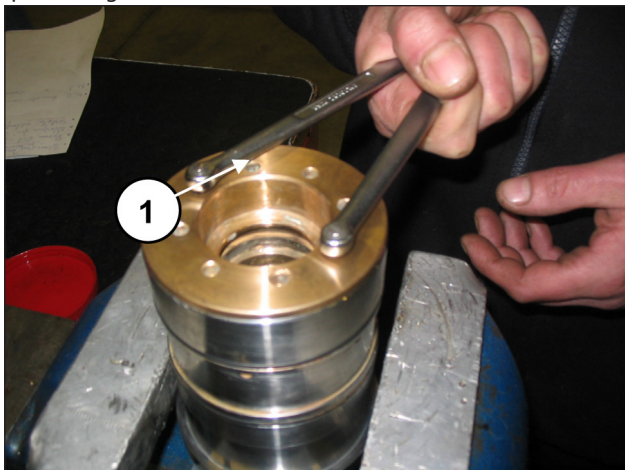

Fig. 145

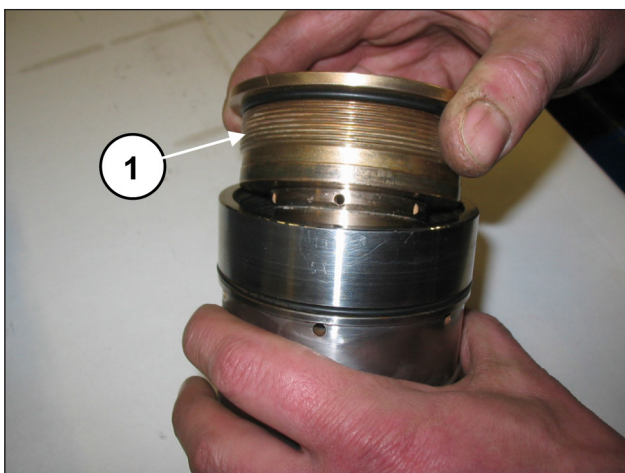

Fig. 146

Extraer a mano las anillas del cuello, las juntas de presión y las anillas restop (pos. ①, Fig. 147).



Fig. 147

Para quitar la junta de baja presión, es necesario utilizar un espesímetro o una herramienta que no dañe el alojamiento del soporte de la junta (pos. ①, Fig. 148).

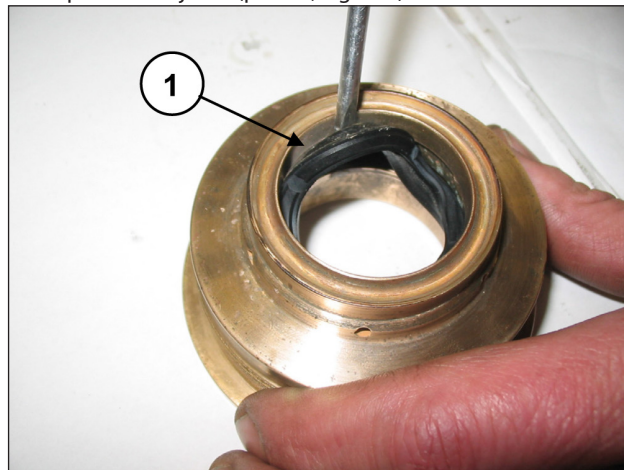

Fig. 148

2.2.4 Montaje del grupo pistón - soportes - juntas

Seguir en orden contrario la secuencia de desmontaje descrita en el apart. 2.2.3.



Sustituir las juntas de presión, para ello humedecer los labios con grasa de silicona (sin esparcir) e introducir las en la camisa con cuidado para no dañarlas.



Sustituir las juntas de presión y las juntas tóricas cada vez que se realicen operaciones de desmontaje.

Introducir la junta de baja presión en el soporte de la junta (pos. ①, Fig. 149) controlando el sentido de montaje (el labio de retención debe estar hacia adelante, hacia el cabezal).

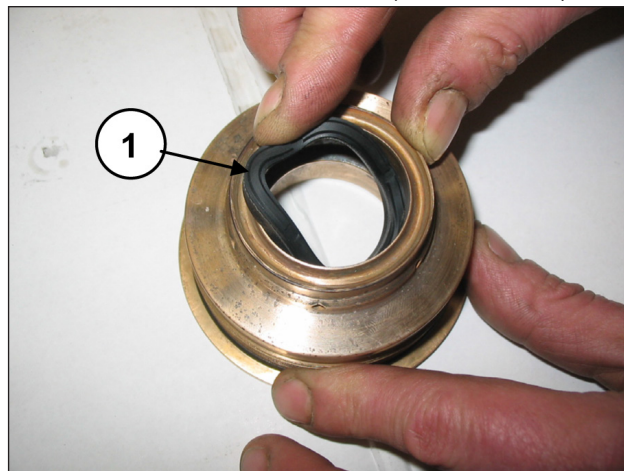

Fig. 149

Montar la anilla del cuello (pos. ①, Fig. 150), la junta de alta presión (pos. ①, Fig. 151) y la anilla restop (pos. ①, Fig. 152).

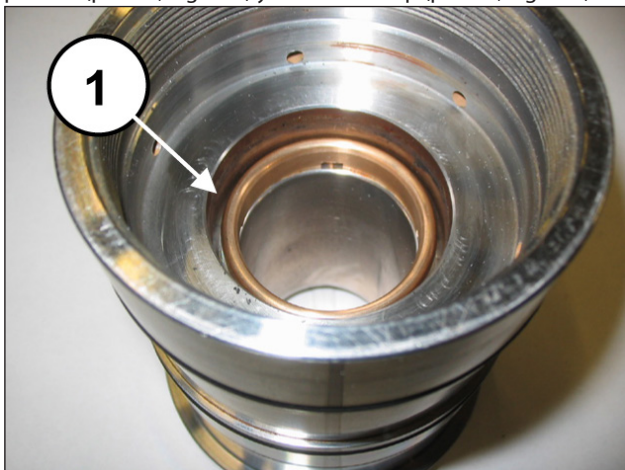

Fig. 150

Introducir la junta tórica del soporte de la junta en el alojamiento (pos. ①, Fig. 153).

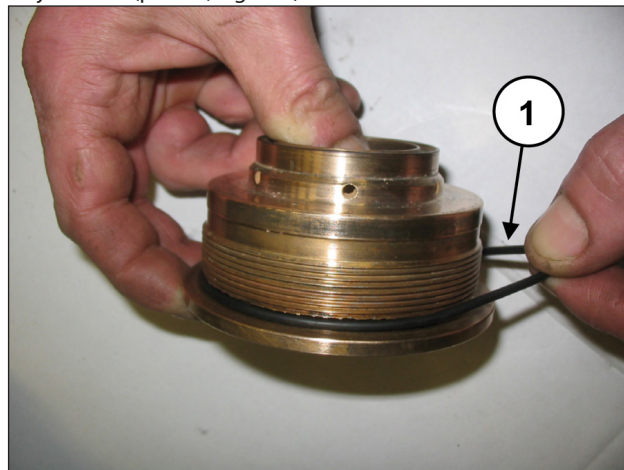

Fig. 153

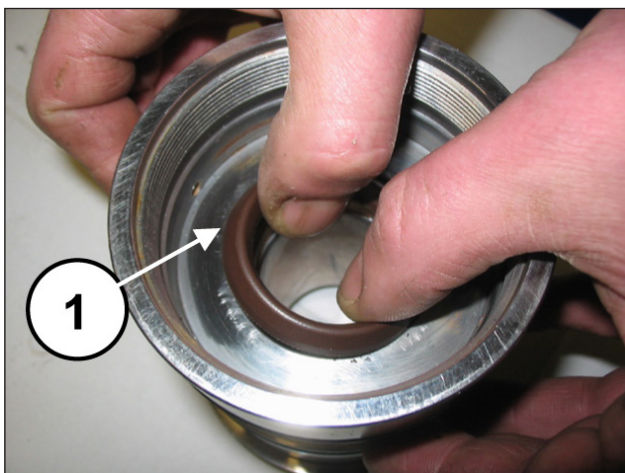

Fig. 151

Enroscar el soporte de las juntas a la camisa (pos. ①, Fig. 154) y apretar con una llave de compás con pivotes redondos Ø5, a la venta en tiendas, (pos. ①, Fig. 155) hasta que el soporte haga tope en la camisa.



Fig. 154



Fig. 152

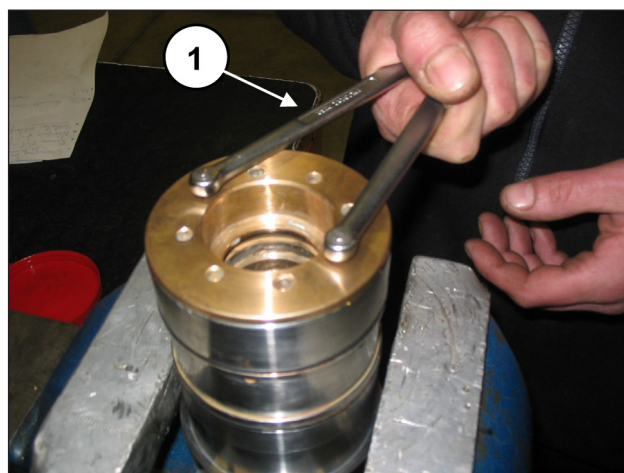

Fig. 155

Introducir la arandela $\varnothing 10 \times 18 \times 0.9$ en el tornillo de fijación del pistón (pos. ①, Fig. 156).

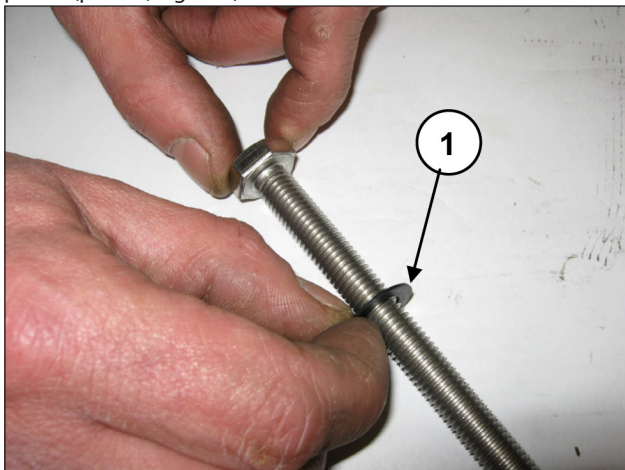

Fig. 156

Introducir a fondo el bloque camisa-soporte junta (con las dos juntas tóricas) ya ensamblado (pos. ①, Fig. 159).

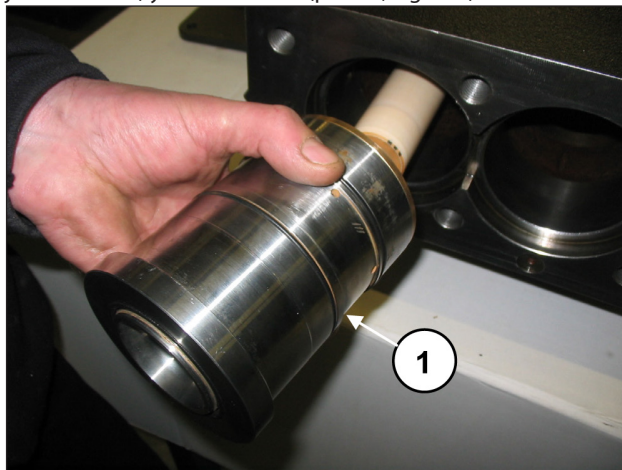

Fig. 159

Montar los pistones en las guías (pos. ①, Fig. 157) y extraerlos como se indica en la pos. ②, Fig. 158.

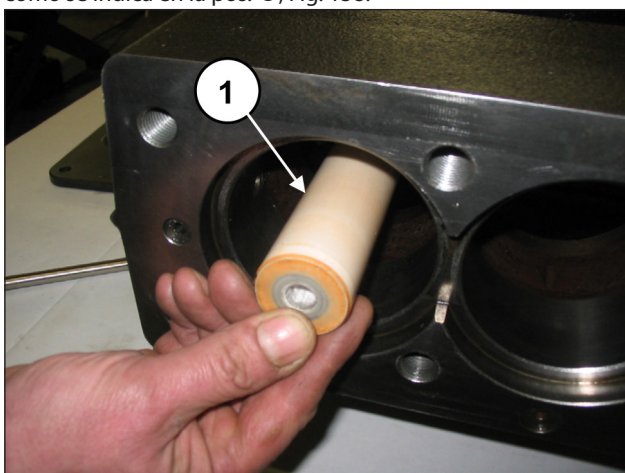

Fig. 157

Comprobar que el bloque camisa-soporte haga tope en el fondo del alojamiento (pos. ①, Fig. 160).

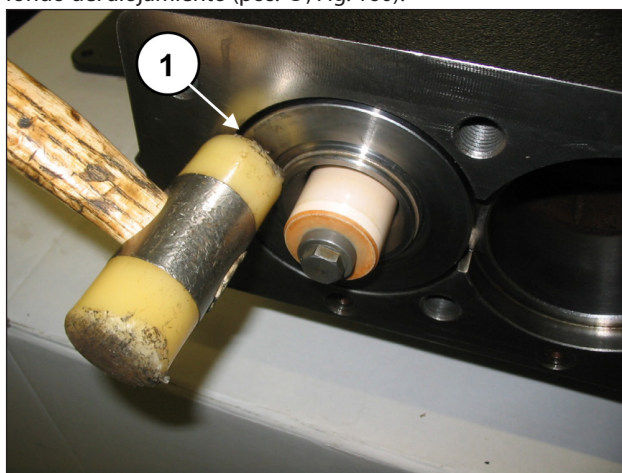

Fig. 160

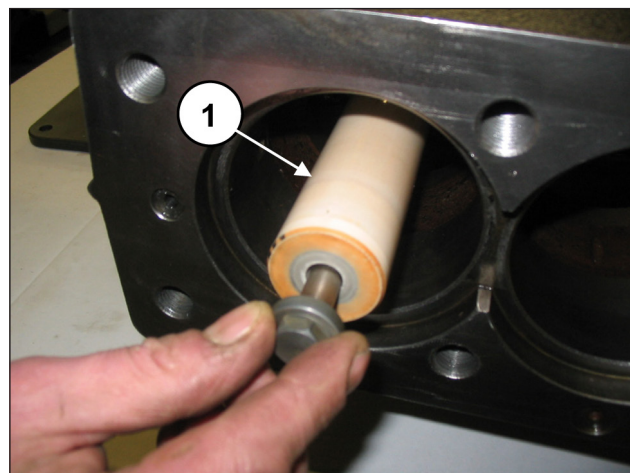

Fig. 158

Montar la junta tórica frontal de la camisa (pos. ①, Fig. 161) y la junta tórica del orificio de recirculación (pos. ①, Fig. 162).

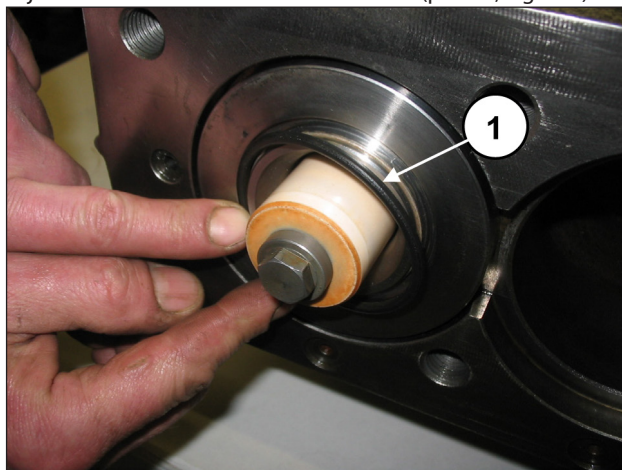

Fig. 161

Ajustar los tornillos con la llave dinamométrica como se indica en el capítulo 3.

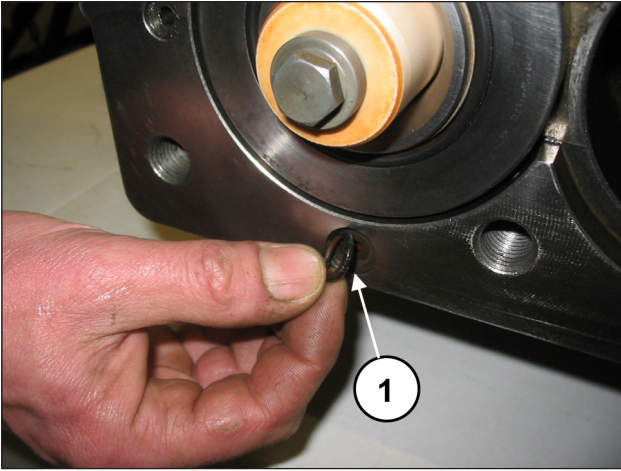

Fig. 162

Introducir la junta tórica (pos. ①, Fig. 163) en las tapas de inspección y montar las tapas con 4+4 tornillos M6x14 (pos. ①, Fig. 164).

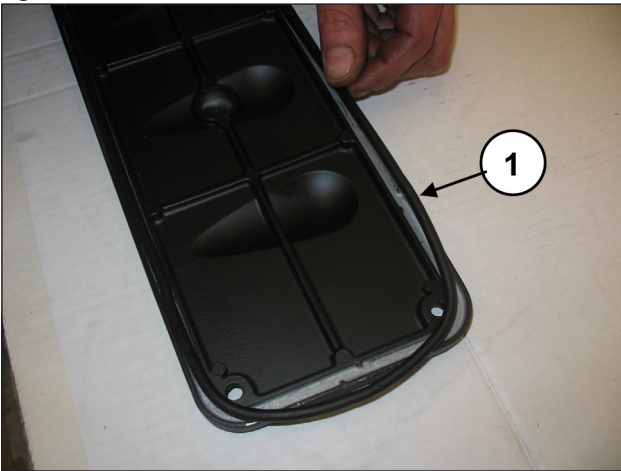

Fig. 163

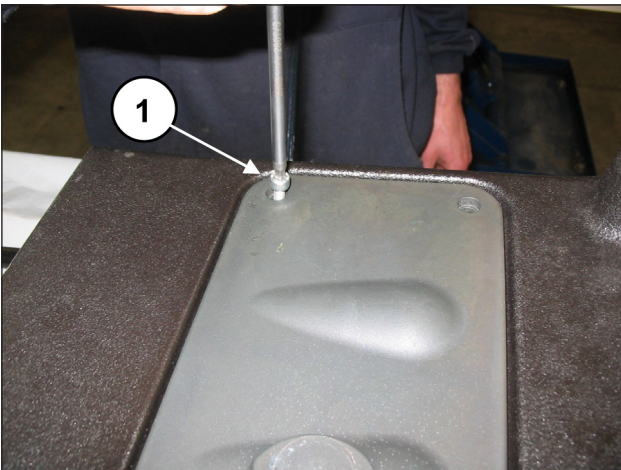

Fig. 164

Ajustar los tornillos con la llave dinamométrica como se indica en el capítulo 3.

2.2.5 Recuperación de cabezas

Si la cabeza presenta dentro de las cámaras de los pistones signos evidentes de cavitación, provocados por una alimentación incorrecta de la bomba, es posible recuperar la cabeza dañada para no tener que sustituirla. Para recuperar la cabeza se han de realizar los trabajos indicados en la Fig. 165 para la LK36-40-45 y en la Fig. 166 para LK50-55-60:

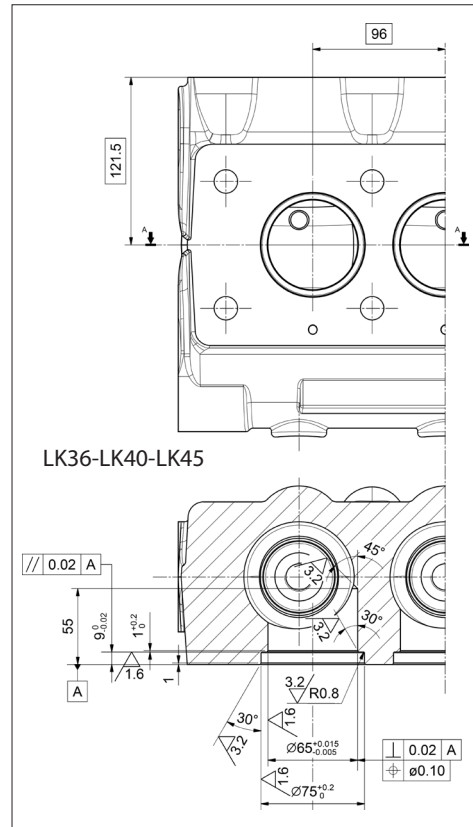

Fig. 165

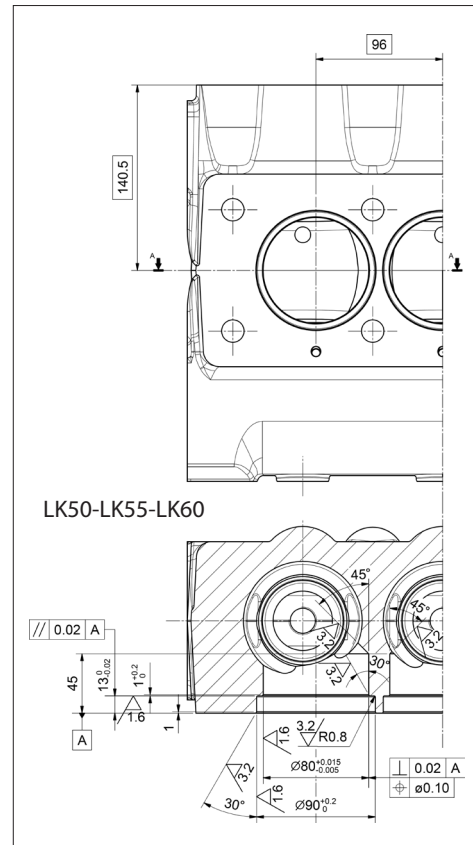

Fig. 166

La cabeza ya trabajada se ha de ensamblar mediante la introducción de los casquillos (pos. ①) con anillas anti extrusión (pos. ②) y las juntas tóricas (pos. ③) como muestra la Fig. 167 para LK36-40-45 y la Fig. 168 para LK50-55-60:

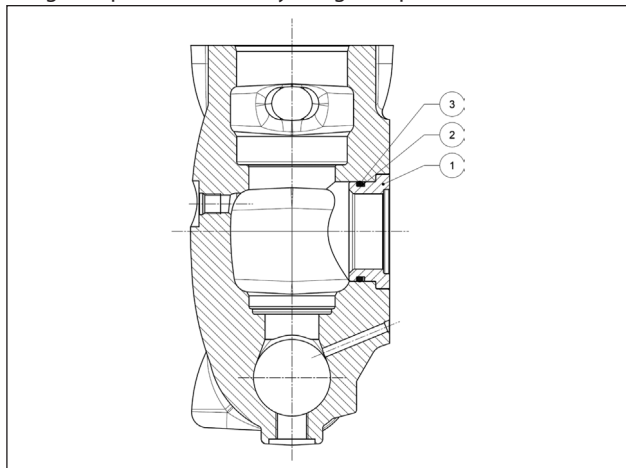

Fig. 167

- 1 - Casquillo LK36-40-45 - cód. 78216756 - cant. 3
- 2 - Anilla anti extrusión - cód. 90526880 - cant. 6
- 3 - Junta tórica - cód. 90410200 - cant. 6

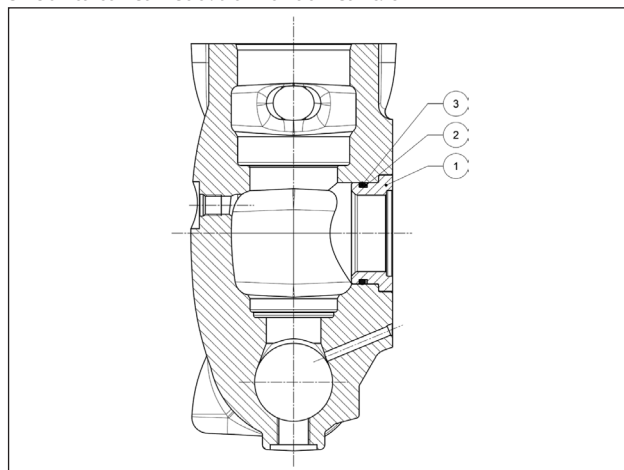

Fig. 168

- 1 - Casquillo LK50-55-60 - cód. 78216656 - cant. 3
- 2 - Anilla anti extrusión - cód. 90528500 - cant. 6
- 3 - Junta tórica - cód. 90412900 - cant. 6

3 CALIBRACIÓN DE AJUSTE DE LOS TORNILLOS

El ajuste de los tornillos debe realizarse exclusivamente con una llave dinamométrica.

Descripción	Posición dibujo desglosado	Par de apriete Nm
Tornillo M8x20 de la tapa del cárter	54	25
Tapón G1/2x13 del cárter	78	40
Tornillo M8x30 tapa cojinete PTO	95	25
Tornillo M8x20 tapa extremo eje	54	25
Tornillo M10x30 tapa portacojinete	69	45
Tornillo M6x14 de las tapas superior e inferior	82	10
Tornillo M8x20 de la tapa del cojinete	54	25
Tornillo M12x1.25x87 de apriete de la biela	52	75*
Tornillo M6x20 de la guía del pistón	49	10
Tornillo M12x25 brida bloqueo casquillo	63	68.5
Tornillo M10x160 de fijación del pistón	27	40
Tornillo M16x55 de la tapa de válvulas	26	333
Tapón G1/4"x13 cabeza	13	40
Tornillo M16x150 de la cabeza	25	333**
Dispositivo de apertura de las válvulas	2	40

* Ajustar el par de apriete atornillando los tornillos de modo simultáneo.

** Apretar en diagonal los 4 tornillos internos (ver Fig. 135y a continuación los 4 externos).

4 HERRAMIENTAS DE REPARACIÓN

El mantenimiento de la bomba se puede llevar a cabo utilizando herramientas estándar para el montaje y el desmontaje de los componentes. Están disponibles las siguientes herramientas:

Para el montaje:

Anilla de retención radial de la guía del pistón	cód. 27910900
Anilla de retención radial del eje PTO	cód. 27539500
	cód. 27548200
Junta tórica del alojamiento de la válvula de envío LK36-LK40-LK45	cód. 27516000
Junta tórica del alojamiento de la válvula de envío LK50-LK55-LK60	cód. 27516100

Para el desmontaje:

Alojamiento de válvula de aspiración LK36-LK40-LK45	cód. 27516200
Alojamiento de válvula de aspiración LK50-LK55-LK60	cód. 27516300
Alojamiento de la válvula de envío	cód. 27516400
Bloque camisa + soporte de juntas	cód. 27516600
Eje (bloqueo de las bielas)	cód. 27566200

5 VERSIONES ESPECIALES

A continuación se describe cómo reparar las versiones especiales. En los casos no especificados, respetar las instrucciones relativas a la versión de bomba LK estándar.

- Bombas LKN: seguir las instrucciones de la bomba MW estándar.

6 SUSTITUCIÓN DEL CASQUILLO PIE DE LA BIELA

Realizar la conexión del casquillo en frío y los trabajos necesarios respetando las dimensiones y las tolerancias indicadas en la Fig. 169.

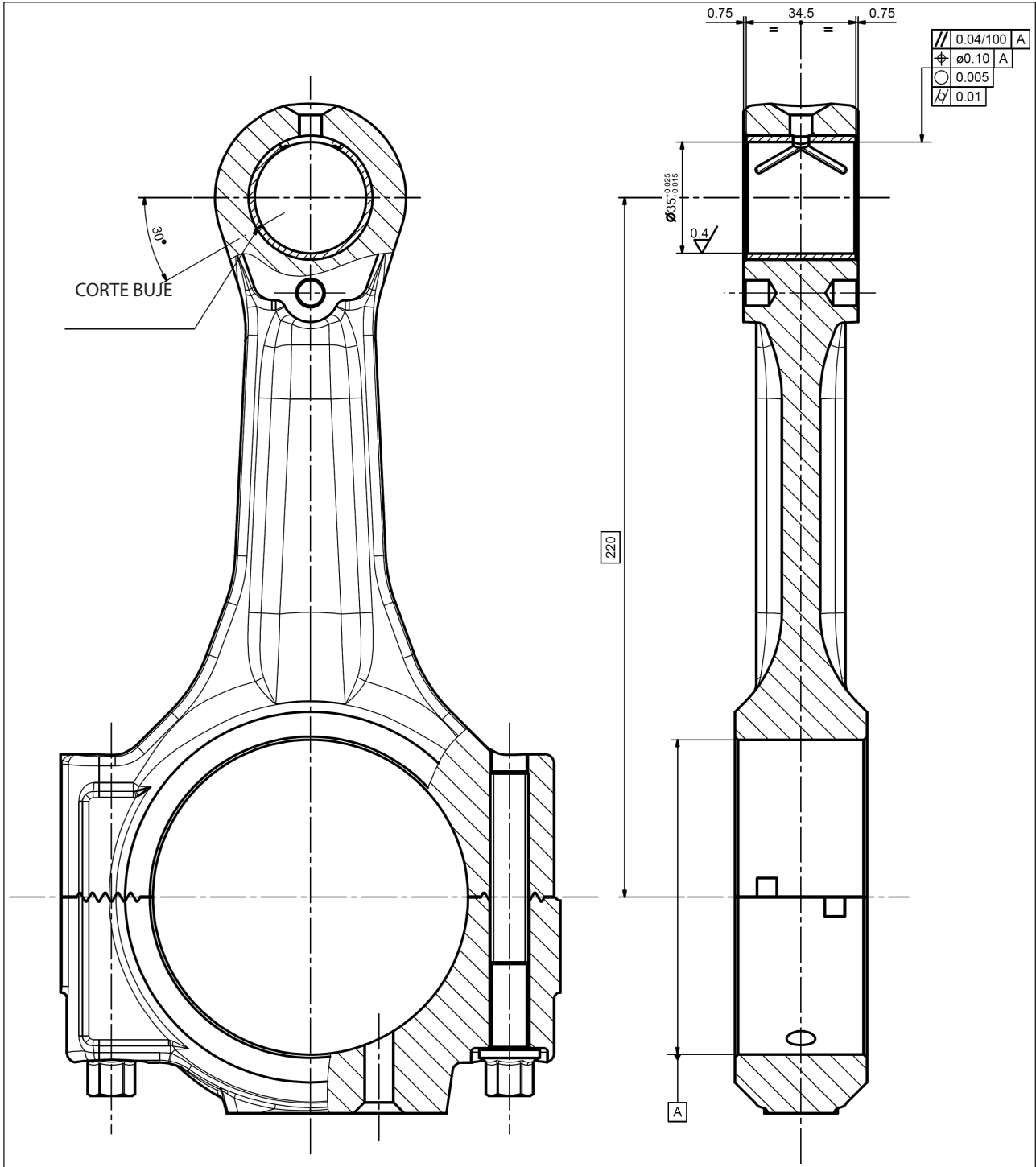

Fig. 169

Resumo

1	INTRODUÇÃO	172
1.1	DESCRIÇÕES DOS SÍMBOLOS.....	172
2	NORMAS DE REPARAÇÃO	172
2.1	REPARAÇÃO DA PARTE MECÂNICA.....	172
2.1.1	<i>Desmontagem da parte mecânica</i>	172
2.1.2	<i>Montagem da parte mecânica</i>	180
2.1.3	<i>Classes de aumento previstas</i>	190
2.2	REPARAÇÃO DA PARTE HIDRÁULICA	190
2.2.1	<i>Desmontagem do cabeçote - grupos da válvula</i>	190
2.2.2	<i>Montagem do cabeçote - grupos da válvula</i>	192
2.2.3	<i>Desmontagem do grupo do pistão - suportes - vedação</i>	196
2.2.4	<i>Montagem do grupo do pistão - suportes - vedação</i>	198
2.2.5	<i>Recuperação dos cabeçotes</i>	201
3	CALIBRAGEM DO APERTO DOS PARAFUSOS	202
4	FERRAMENTAS PARA A REPARAÇÃO	203
5	VERSÕES ESPECIAIS	203
6	SUBSTITUIÇÃO DA BUCHA DO PÉ DA HASTE	204

1 INTRODUÇÃO

Este manual descreve as instruções para a reparação das bombas da família LK e deve ser atentamente lido e compreendido antes de realizar qualquer intervenção na bomba.

O uso correto e manutenção adequada depende do funcionamento e duração regular da bomba.

A Interpump Group não se responsabiliza por qualquer dano causado por mau uso ou pelo não cumprimento das regras descritas neste manual.

1.1 DESCRIÇÕES DOS SÍMBOLOS

Leia atentamente as instruções contidas neste manual antes de qualquer operação.



Sinal de Advertência



Leia atentamente as instruções contidas neste manual antes de qualquer operação.



Sinal de Perigo

Use óculos de proteção.



Sinal de Perigo

Use luvas de proteção antes de cada operação.

2 NORMAS DE REPARAÇÃO



2.1 REPARAÇÃO DA PARTE MECÂNICA

As operações de reparação da parte mecânica devem ser realizadas depois de ter removido o óleo do carter.

Para retirar o óleo, é preciso remover a tampa de carga do óleo pos. ①, Fig. 1 e em seguida, a tampa de descarga pos. ②, Fig. 1.

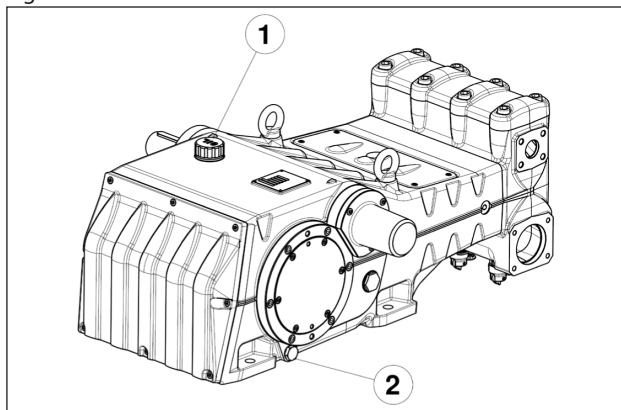

Fig. 1



O óleo esgotado deve ser colocado em um recipiente adequado e disposto em centrais adequadas.

Não deve ser, de forma nenhuma, disposto no meio ambiente.

2.1.1 Desmontagem da parte mecânica

A sequência correta é a seguinte:

Esvazie completamente o óleo da bomba, conforme indicado no parág. 2.1.

Desmonte as alças da válvula do cabeçote e o cabeçote do carter da bomba, conforme indicado no parág. 2.2.1 (da Fig. 103 a Fig. 105).

Remova a cobertura de inspeção superior e de inspeção inferior, soltando os 4+4 parafusos de fixação, conforme indicado no parág. 2.2.3 (Fig. 139 e Fig. 140).

Solte os anéis circulares e substitua-os, se for necessário.

Remova os três pistões e grupos da camisa-suportes do forro, conforme indicado no parág. 2.2.3 (Fig. 138, Fig. 141 e Fig. 142).

Remova os três anéis espaçadores de proteção contra espirros, conforme indicado no parág. 2.2.3 (Fig. 143 e Fig. 144).

Solte os grãos de bloqueio M6 das três coberturas da vedação do óleo (pos. ①, Fig. 2).

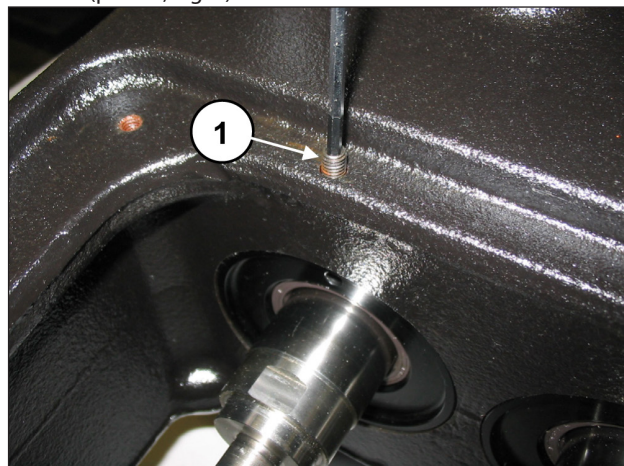

Fig. 2

Aperte uma haste rosqueada ou um parafusos M6 com função de extrator nos furos adequados na cobertura da vedação do óleo (pos. ①, Fig. 3) e extraia as coberturas do grupo da bomba (pos. ①, Fig. 4).

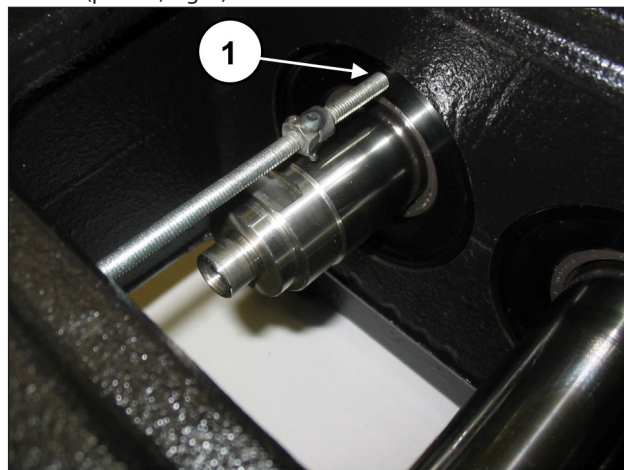

Fig. 3

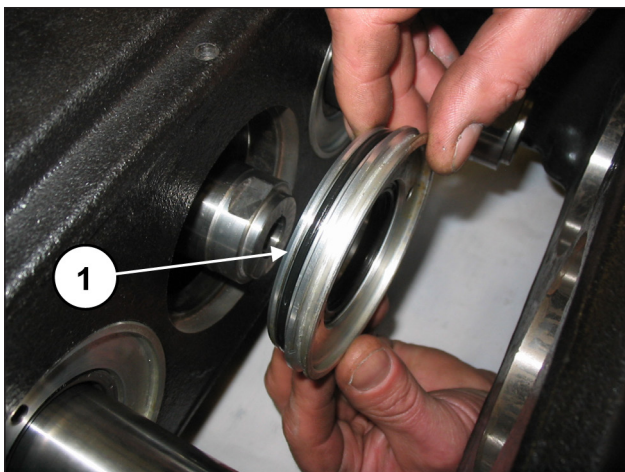

Fig. 4

Extraia o anel de vedação radial (pos. ①, Fig. 5) e o anel circular externo (pos. ①, Fig. 6).

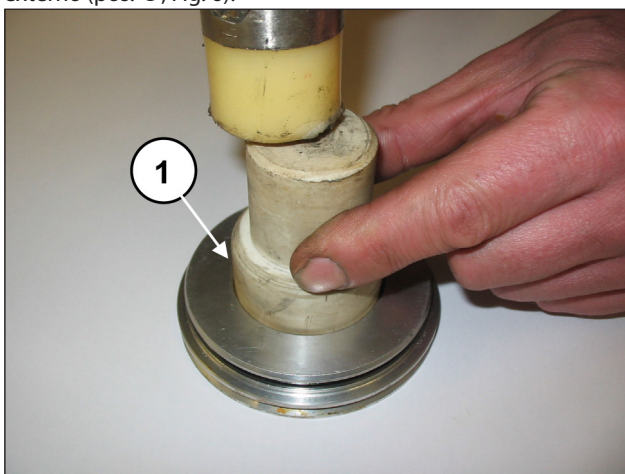

Fig. 5

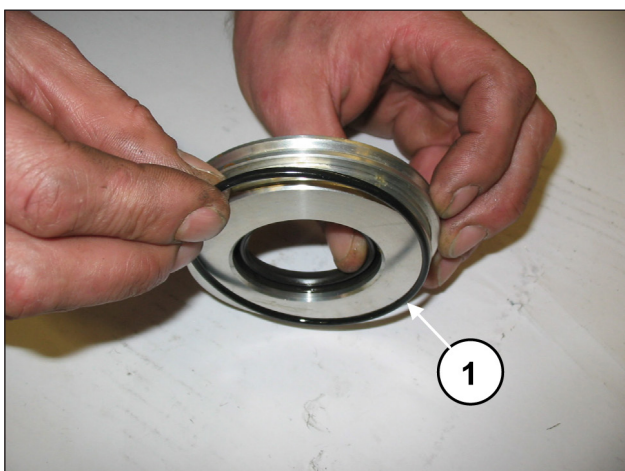

Fig. 6

Remova a lingueta do eixo PTO (pos. ①, Fig. 7).

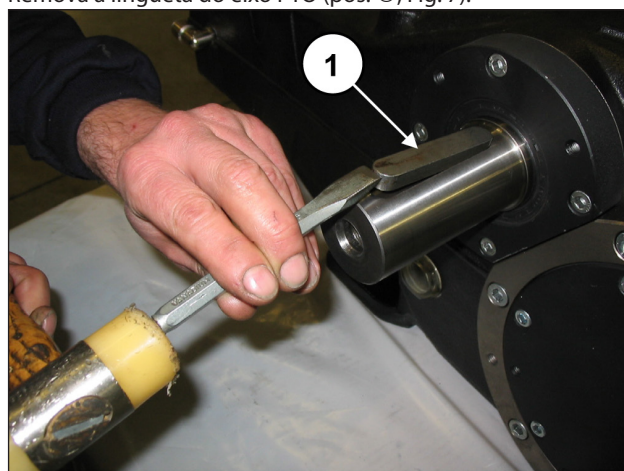

Fig. 7

Solte os parafusos de fixação da cobertura da extremidade do eixo (pos. ①, Fig. 8) e retire a cobertura do eixo PTO.

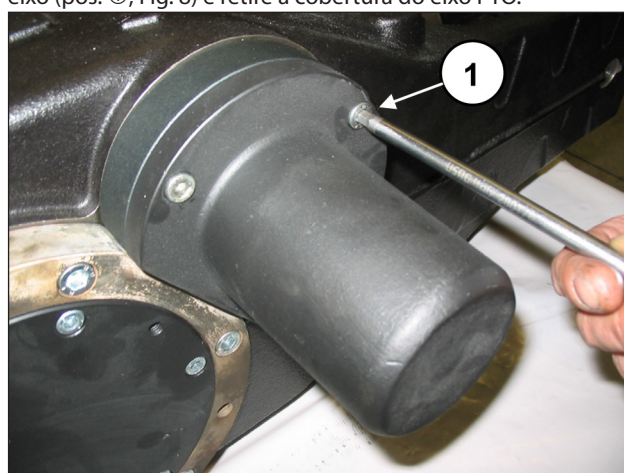

Fig. 8

Solte os parafusos de fixação da cobertura do carter (pos. ①, Fig. 9) e remova-o. Retire o anel circular e substitua-o, se for necessário.

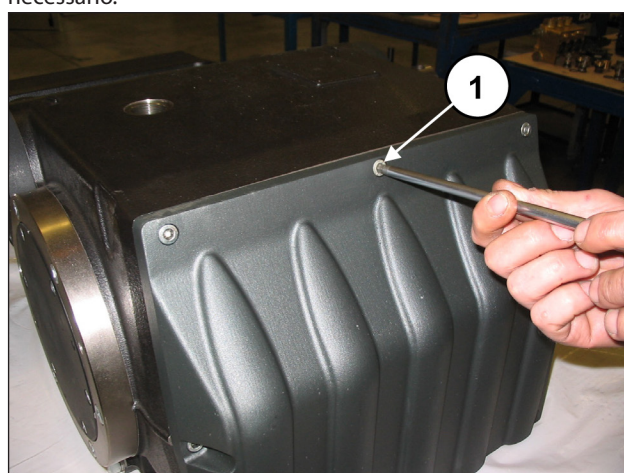

Fig. 9

Proporcione agora a desmontagem das duas coberturas do rolamento, soltando os parafusos relativos (pos. ①, Fig. 10). Para facilitar a desmontagem, use dois grãos ou parafusos M8 (pos. ①, Fig. 11), com a função de extratores. Retire o anel circular e substitua-o, se for necessário.

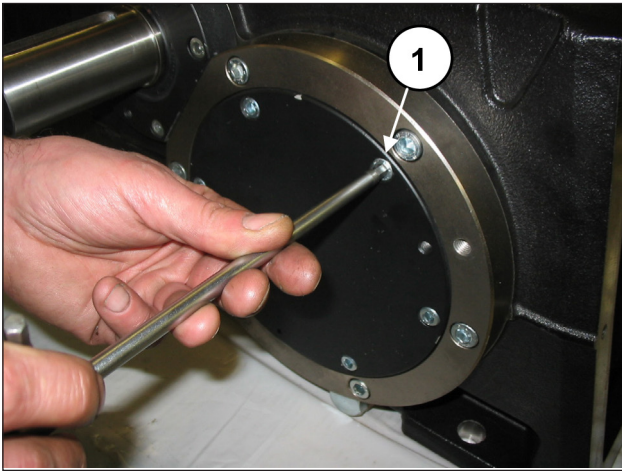

Fig. 10

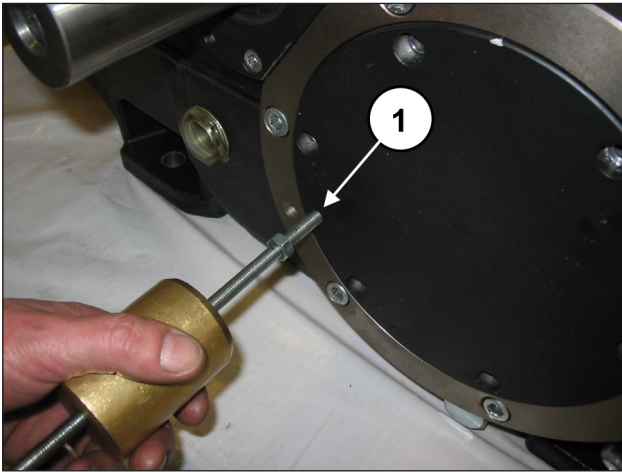

Fig. 11

Insira uma espessura sob o corpo da haste central para bloquear a rotação do eixo de manivela (pos. ①, Fig. 12).

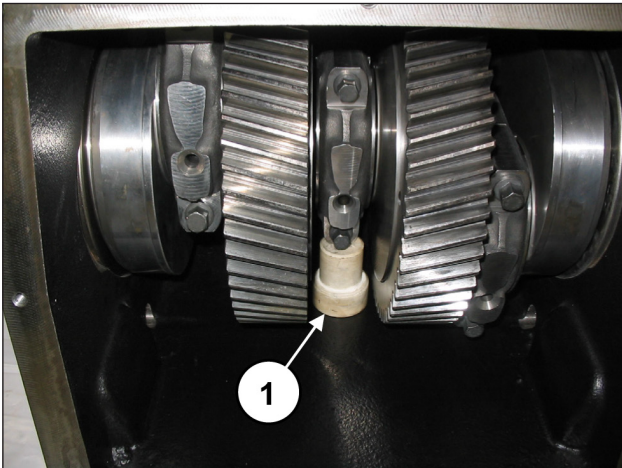

Fig. 12

Solte e extraia os parafusos de fixação da flange de bloqueio da bússola, de ambos os lados (pos. ①, Fig. 13). A flange de bloqueio da bússola deve ser deixada no local (pos. ①, Fig. 14).

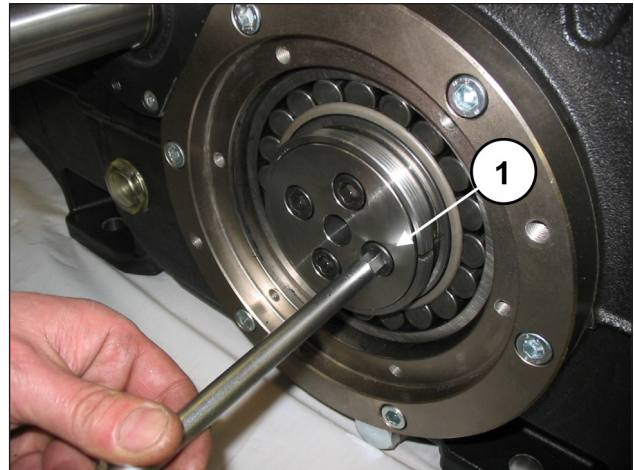

Fig. 13

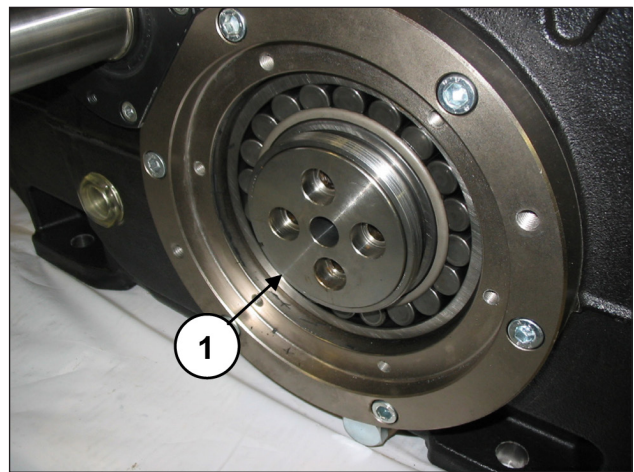

Fig. 14

Se um lado, aperte um anel do tipo SKF KM20 na bússola de pressão (pos. ①, Fig. 15), em seguida, desbloqueie a bússola mediante o mecanismo de percussão (pos. ①, Fig. 16), sem extraí-la.

Repita a operação do lado oposto.

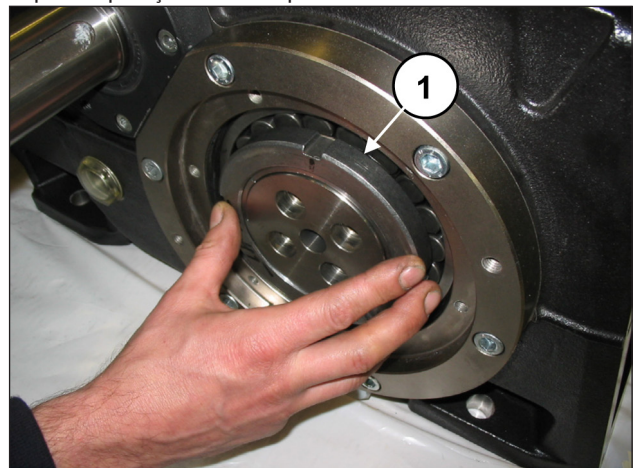

Fig. 15

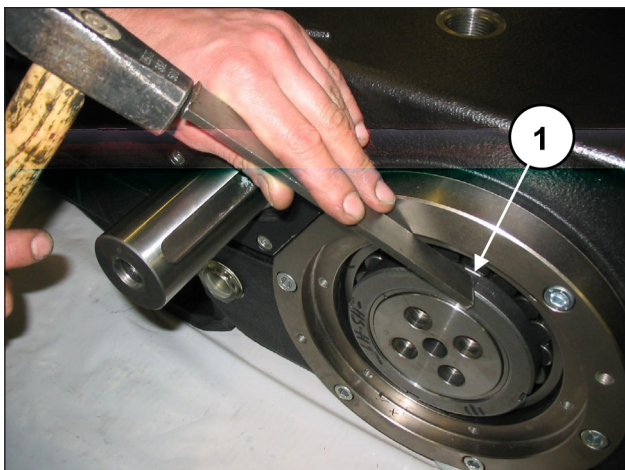

Fig. 16

Retire a espessura sob o corpo da haste central. Solte os parafusos da haste (pos. ①, Fig. 17).

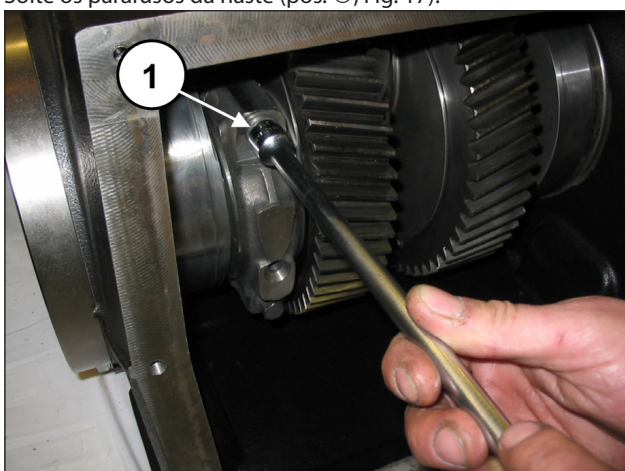

Fig. 17

Desmonte os chapéus da haste com os semi-rolamentos tendo cuidado especial durante a desmontagem, da ordem em que são desmontados.



Os chapéus da haste e as semi-hastes relativas devem ser remontados exatamente na mesma ordem e acoplamento em que foram desmontados.

Para evitar possíveis erros do chapéu e semi-hastes, foram numerados em um lado (pos. ①, Fig. 18).

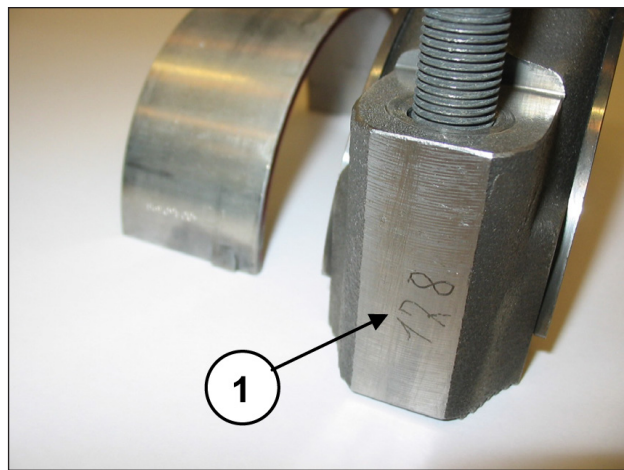

Fig. 18

Avance o máximo possível as três semi-hastes na direção do cabeçote.

Solte os três semi-rolamentos superiores das semi-hastes (pos. ①, Fig. 19).

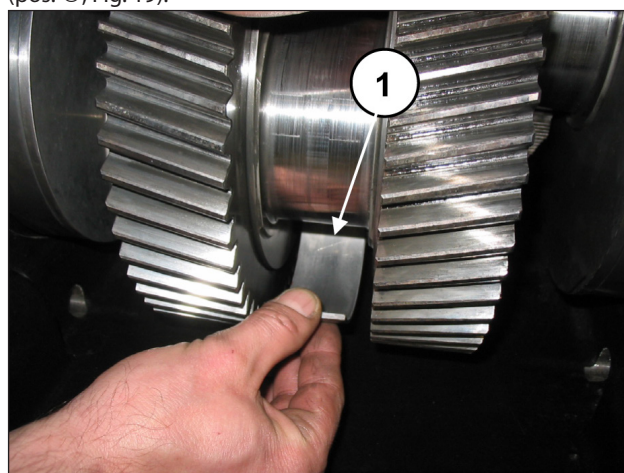

Fig. 19

Retire em ambas as bússolas de pressão (pos. ①, Fig. 20).

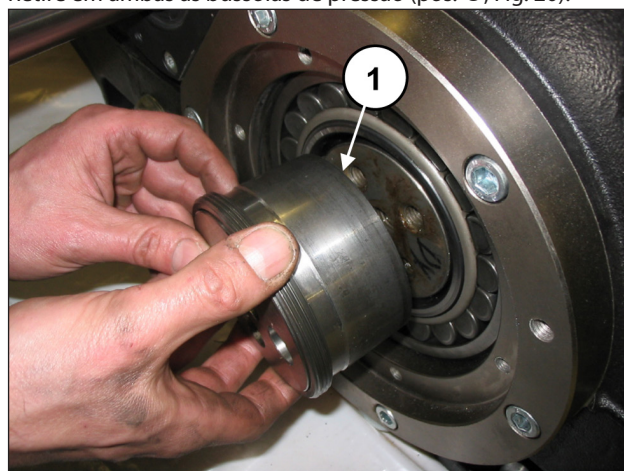

Fig. 20

Separe a flange de bloqueio da bússola de pressão (pos. ①, Fig. 21).

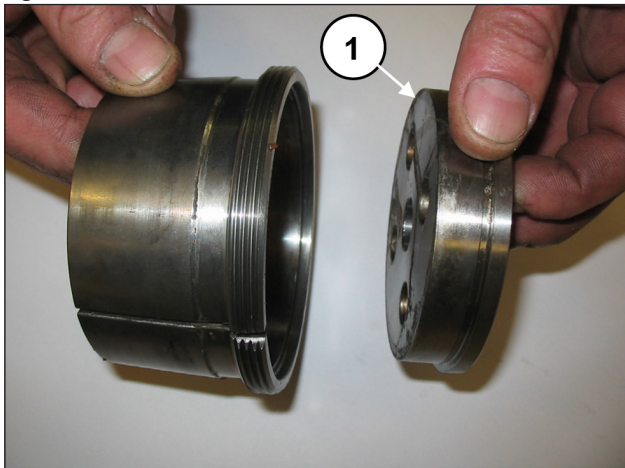

Fig. 21

Solte os parafusos das duas coberturas do porta-rolamento (pos. ①, Fig. 22).

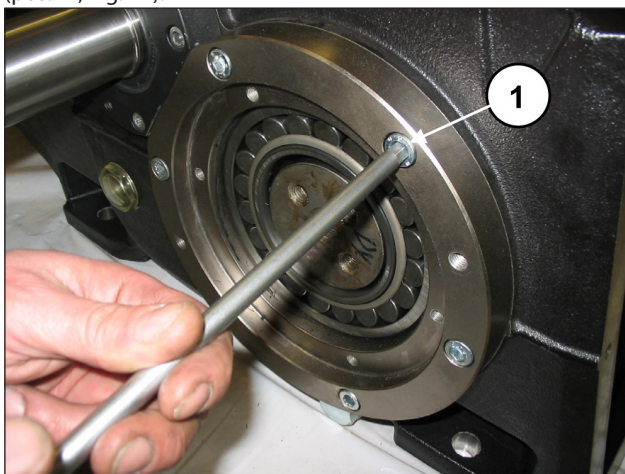

Fig. 22

Aplique um pino rosqueado M16 em uma extremidade do eixo de manivela (pos. ①, Fig. 23) e, mantendo-o elevado, extraia a cobertura do porta-rolamento completo do rolamento e anel circular (pos. ①, Fig. 24). Para agilizar a desmontagem, use dois grãos ou parafusos M10 (pos. ②, Fig. 23), com a função de extratores. Repita a operação do lado oposto.

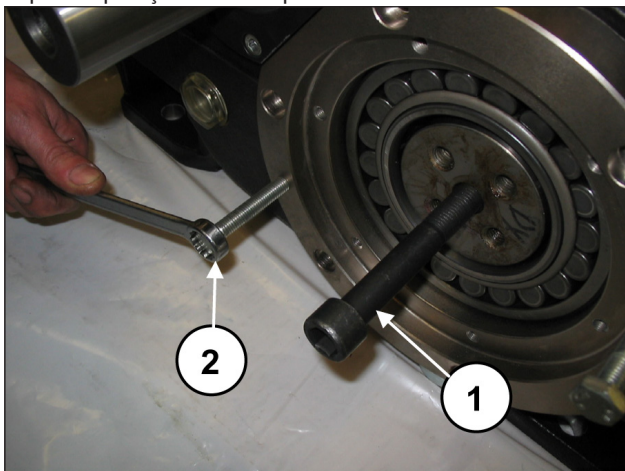

Fig. 23

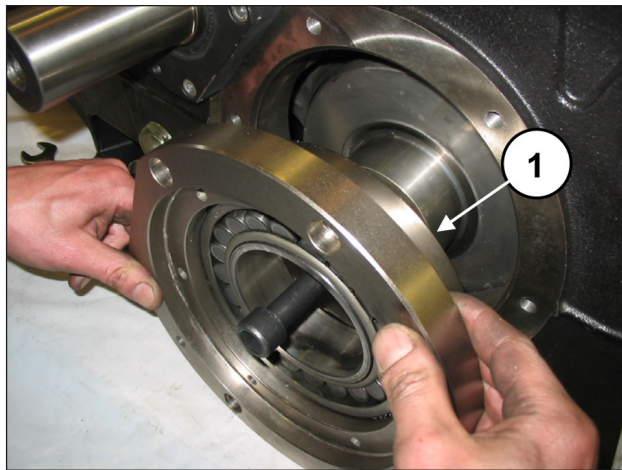

Fig. 24

Apoie o eixo de manivela no fundo do carter. Separe a cobertura do porta-rolamento do rolamento, mediante o uso de um mecanismo de percussão (pos. ①, Fig. 25).

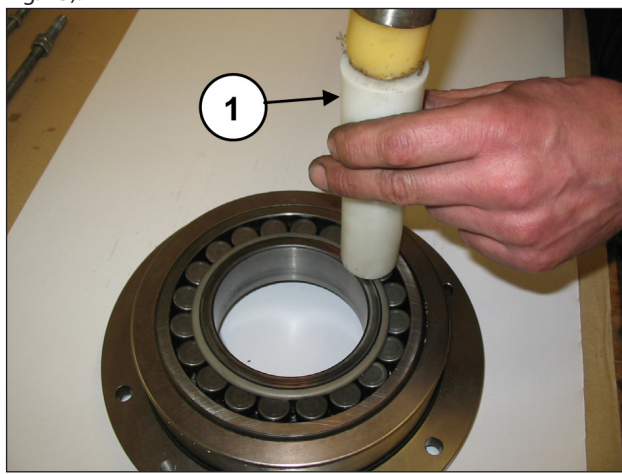

Fig. 25

Solte os parafusos de cobertura do rolamento PTO direito e esquerdo (pos. ①, Fig. 26), e solte as duas coberturas do eixo PTO. Para agilizar a desmontagem, use três grãos ou parafusos M8 (pos. ①, Fig. 27), com a função de extratores.

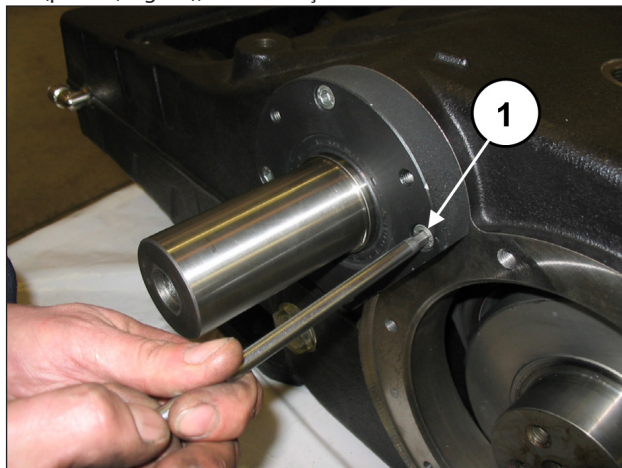

Fig. 26

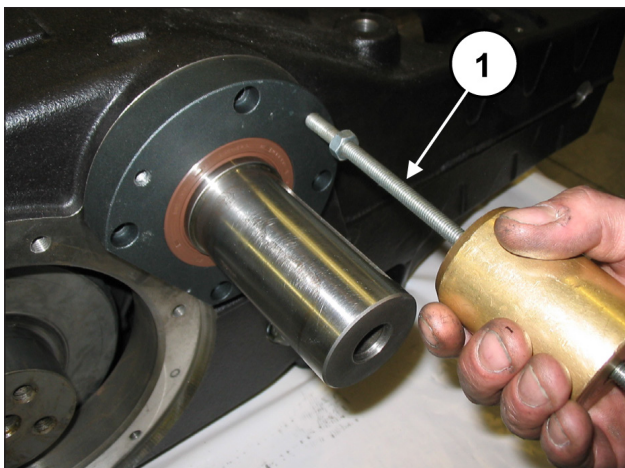

Fig. 27

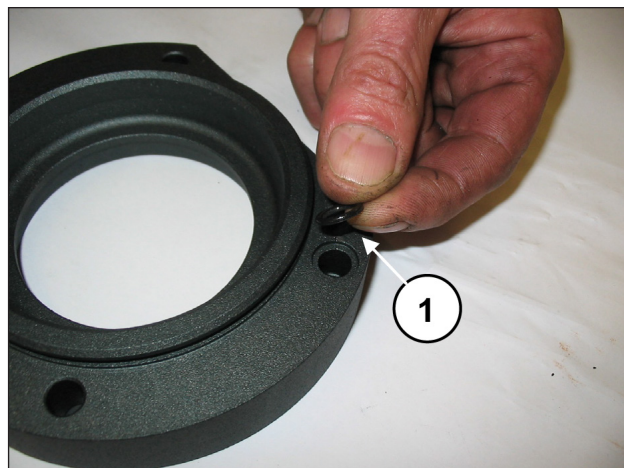

Fig. 30

Extraia o anel de vedação radial (pos. ①, Fig. 28), o anel circular externo (pos. ①, Fig. 29), e o anel circular do furo de lubrificação (pos. ①, Fig. 30).

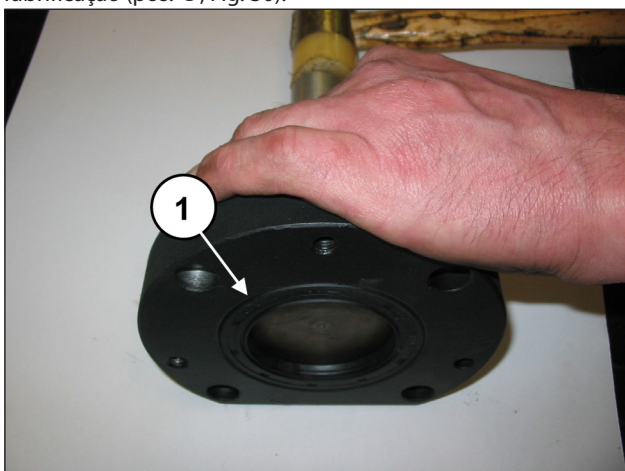

Fig. 28

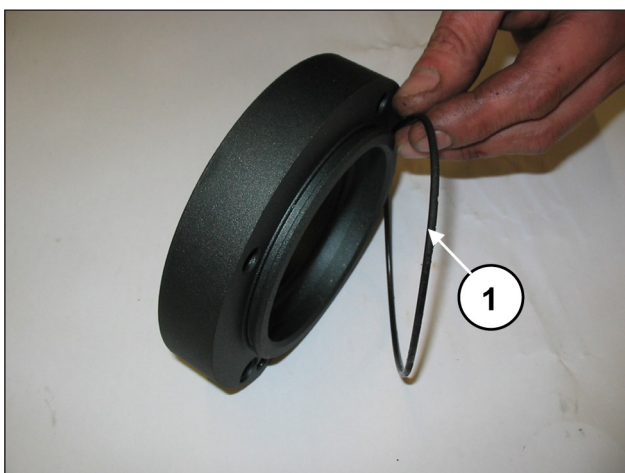

Fig. 29

Volte atrás as três hastes o máximo possível (traga-as em contato com o eixo de manivela).
Mediante o uso de um mecanismo de percussão (pos. ①, Fig. 31), extraia o eixo PTO de qualquer um dos dois lados (pos. ①, Fig. 32).

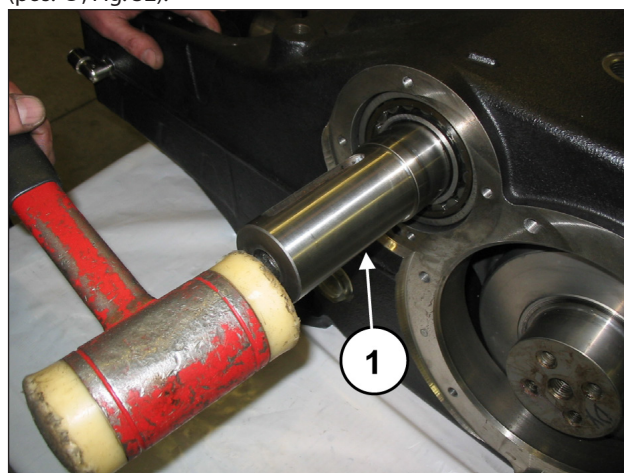

Fig. 31

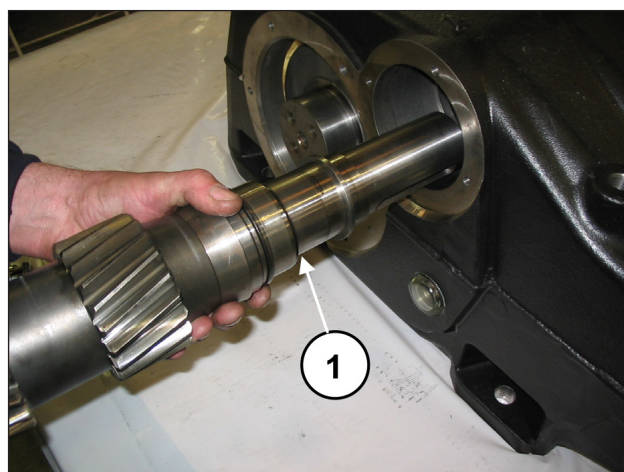

Fig. 32

Solte os anéis internos dos rolamentos do eixo PTO (pos. ①, Fig. 33), e os dois espaçadores do rolamento interno (pos. ②, Fig. 33).

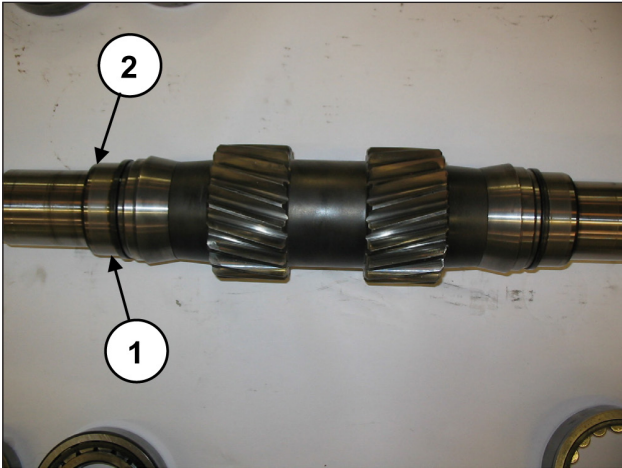

Fig. 33



Os anéis internos e externos dos rolamentos devem ser remontados exatamente na mesma ordem e acoplamento em que foram desmontados.

Mediante o uso de uma barra suficientemente longa (pos. ①, Fig. 34) e de um mecanismo de percussão, extraia do carter da bomba os anéis dos rolamentos (pos. ①, Fig. 35), o espaçador do rolamento externo (pos. ①, Fig. 36) e a bússola de lubrificação dos rolamentos (pos. ①, Fig. 37).

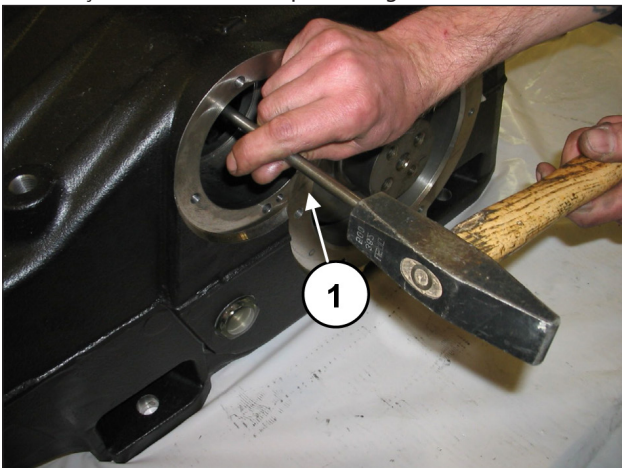

Fig. 34

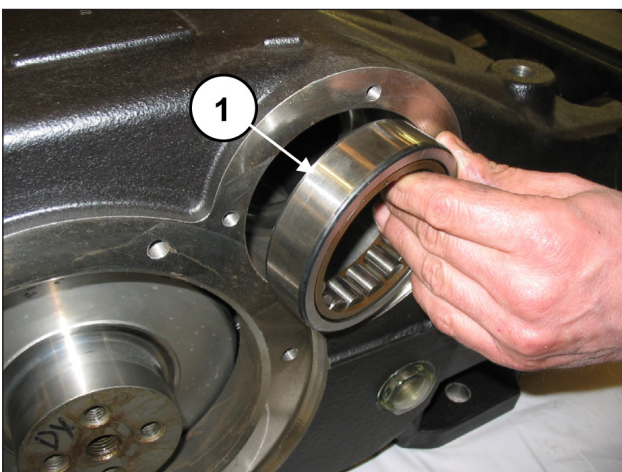

Fig. 35

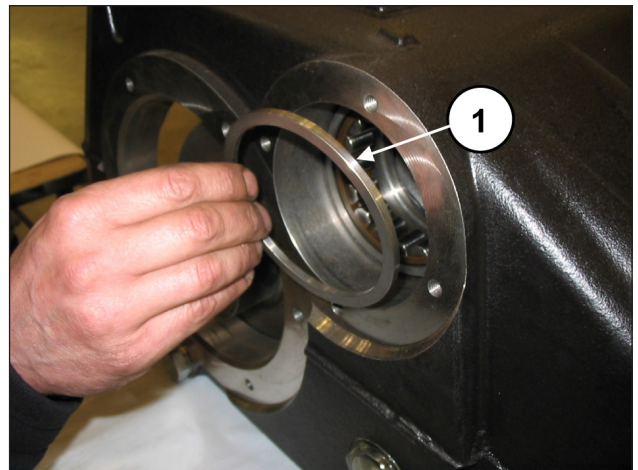

Fig. 36

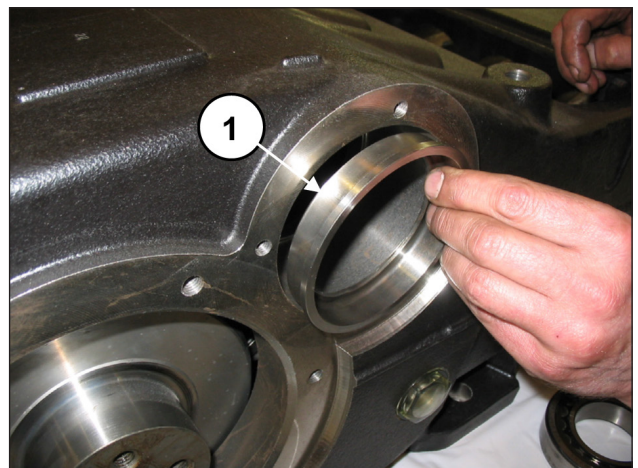

Fig. 37

Avance as semi-hastes na direção da parte hidráulica e bloqueie-as, mediante o uso da ferramenta adequada (cód. 27566200) (pos. ①, Fig. 38).

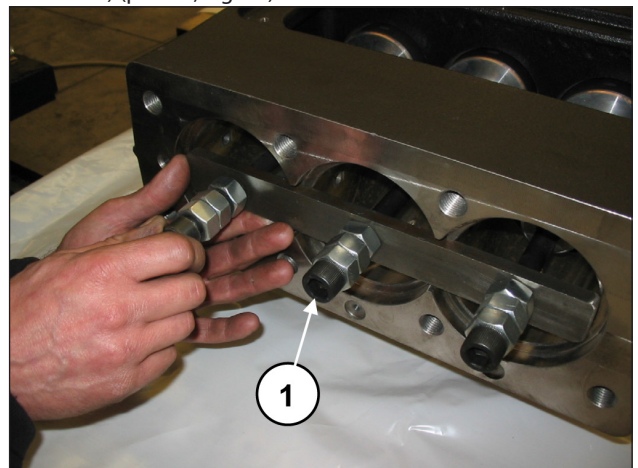

Fig. 38

Retire o eixo de manivela da parte posterior do carter (pos. ①, Fig. 39).

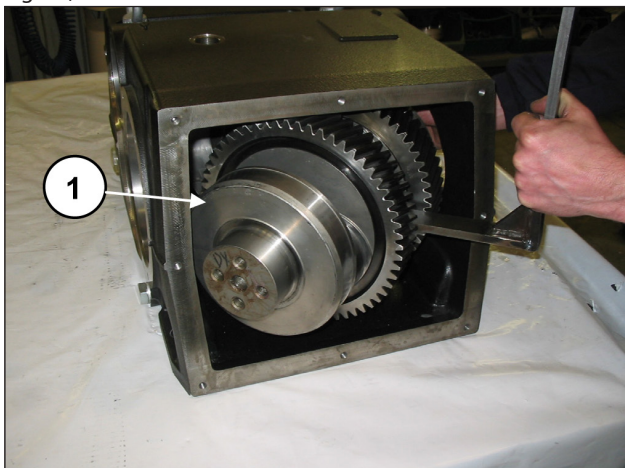

Fig. 39

Prossiga com o desapertar dos parafusos da ferramenta, cód. 27566200, para desbloquear as hastes (pos. ①, Fig. 40) e, em seguida, extraia os grupos da haste-guia do pistão da abertura posterior do carter (pos. ①, Fig. 41).

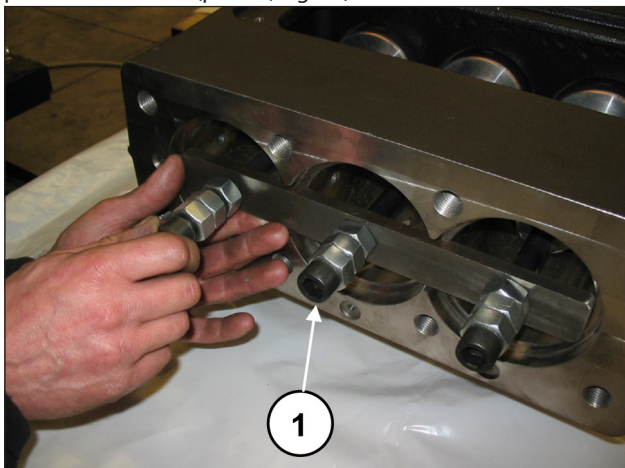

Fig. 40

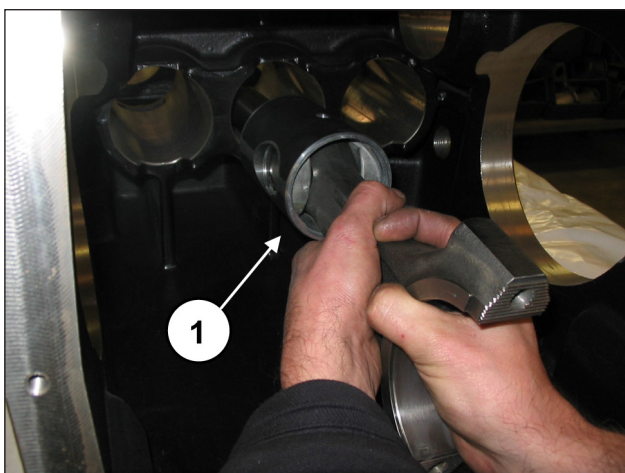

Fig. 41

Acople as semi-hastes aos chapéus anteriormente desmontados, fazendo referência à numeração (pos. ①, Fig. 42).

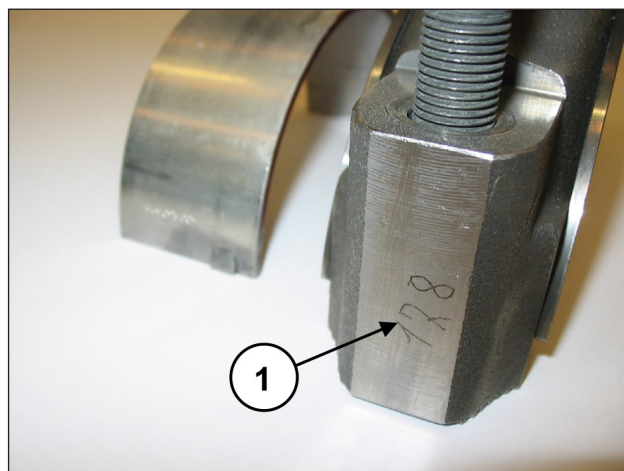

Fig. 42

Remova os dois anéis elásticos de bloqueio do pino, usando uma ferramenta adequada (pos. ①, Fig. 43).

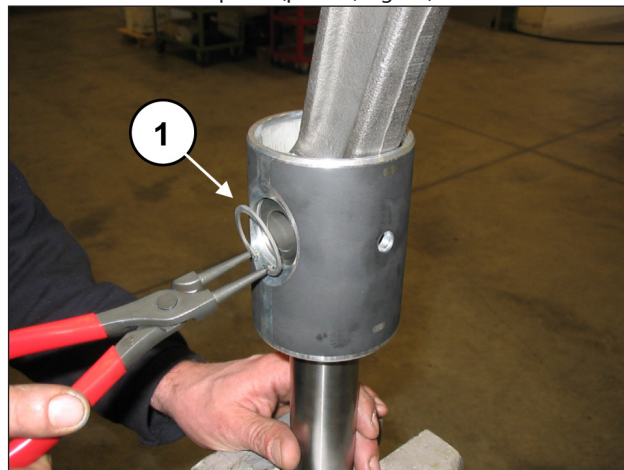

Fig. 43

Solte o pino (pos. ①, Fig. 44) e forneça a extração da haste (pos. ①, Fig. 45).

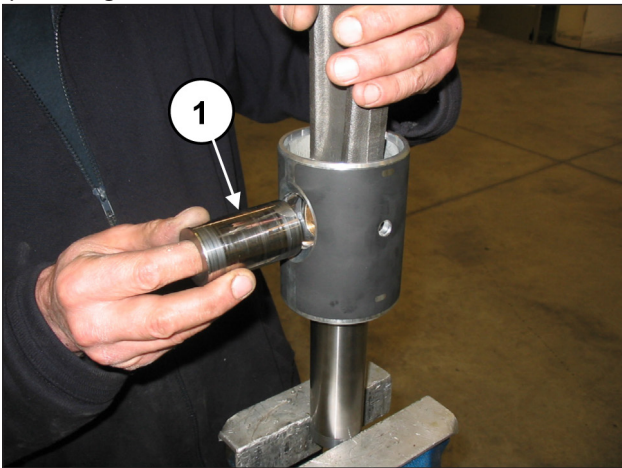

Fig. 44

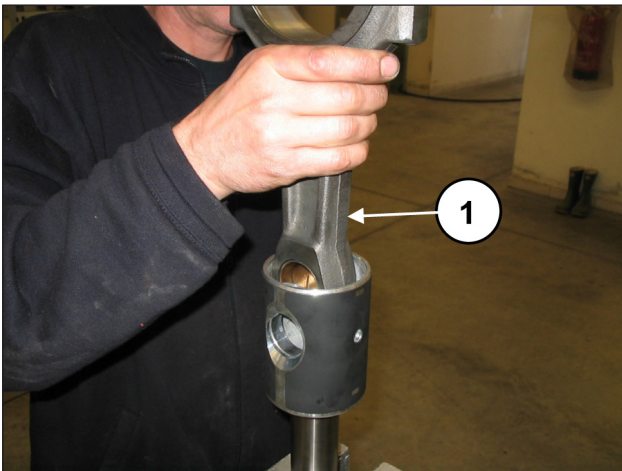

Fig. 45

Para separar a haste da guia do pistão, solte os parafusos do cabeçote cilíndrico M6, mediante a chave especial (pos. ①, Fig. 46).

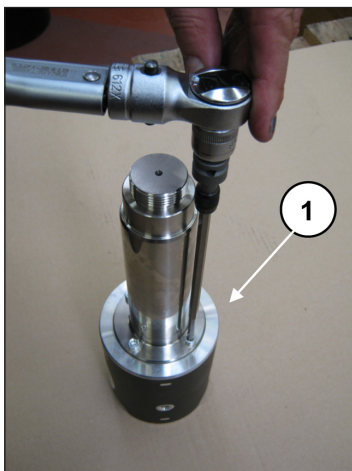

Fig. 46

Complete a desmontagem da parte mecânica, desmontado as luzes do nível do óleo e os olhais.

2.1.2 Montagem da parte mecânica

Proceda com a montagem, seguindo o procedimento inverso ao indicado no parág. 2.1.1.

A sequência correta é a seguinte:

Monte as duas luzes do nível do óleo, as duas tampas de descarga do óleo e a ligação com engate rápido de 90° (pos. ①, ② e ③ Fig. 47).

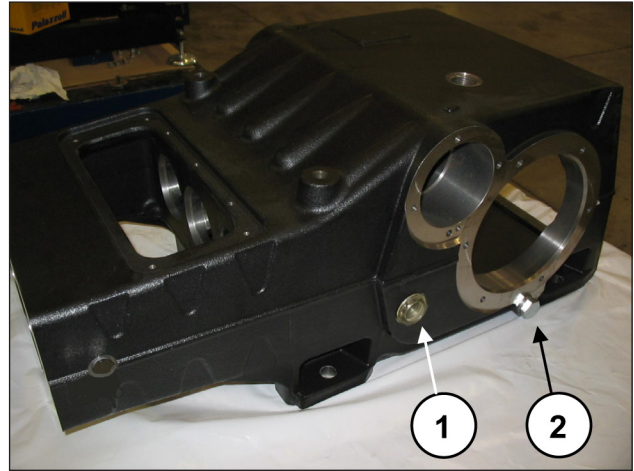

Fig. 47

Monte o mesmo na guia do pistão.

Insira a mesma guia do pistão no local especial da guia do pistão (pos. ①, Fig. 48) e fixe-a a este último com os quatro parafusos do cabeçote cilíndrico M6x20 (pos. ①, Fig. 49).



Fig. 48

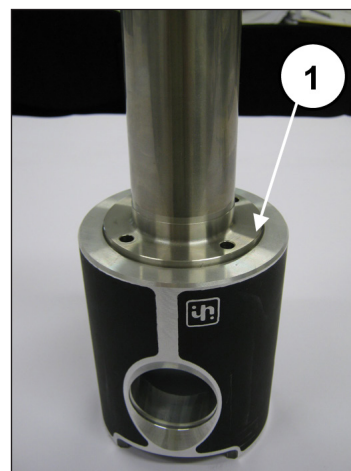

Fig. 49

Bloqueie a guia do pistão no gancho com ajuda de ferramenta adequada e proceda com a calibragem dos parafusos com chave dinamométrica (pos. ①, Fig. 50), conforme indicado no capítulo 3.

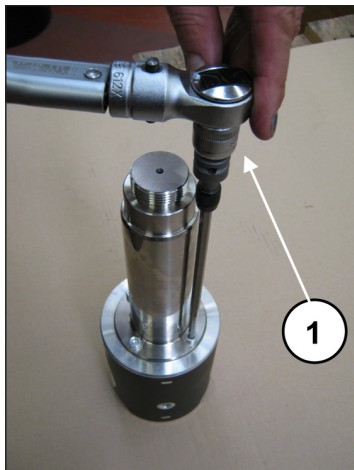

Fig. 50

Insira a haste na guia do pistão (pos. ①, Fig. 45) e, em seguida, insira o pino (pos. ①, Fig. 44). Aplique os dois anéis elásticos do ombro com a ferramenta adequada (pos. ①, Fig. 43).

⚠ A montagem correta é garantida se o pé da haste, a guia do pistão e o pino giram livremente.

Separe os chapéus das semi-hastes. O acoplamento correto será garantido pela numeração colocada em um lado (pos. ①, Fig. 42).

Depois de ter verificado a limpeza correta do carter, insira o grupo da semi-haste-guia do pistão no interior das varas do carter (pos. ①, Fig. 41).

⚠ A inserção do grupo da semi-haste-guia do pistão no carter deve ser feita orientando as semi-hastes com a numeração visível para cima.

Bloqueie os três grupos da ferramenta adequada, cód. 27566200 (pos. ①, Fig. 40).

Insira o eixo de manivela através da abertura posterior do carter e o apoie no fundo.

⚠ A inserção do eixo de manivela no carter deve ser efetuada de modo que os dentes da coroa fiquem voltados, como na Fig. 51.

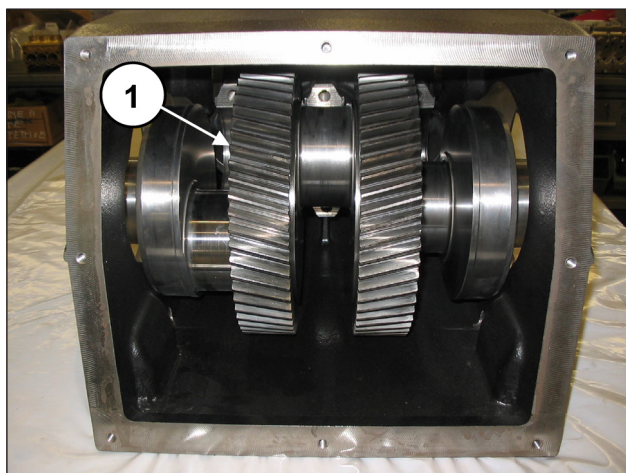

Fig. 51

Pré-monte o eixo PTO:

insira no eixo PTO os dois anéis internos dos rolamentos (um em cada lado) (pos. ①, Fig. 52).

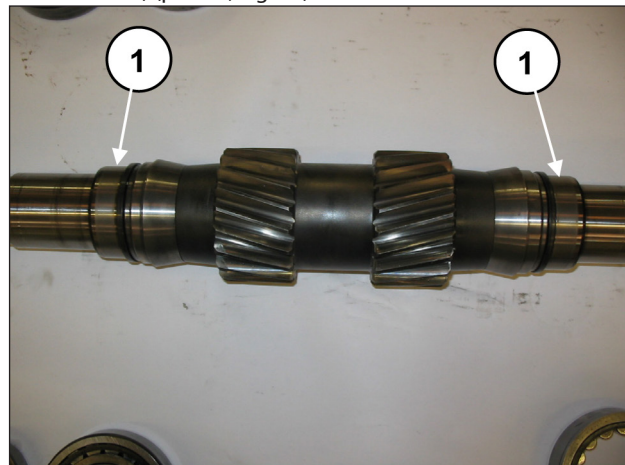

Fig. 52

⚠ Os anéis internos e externos dos rolamentos devem ser remontados exatamente na mesma ordem e acoplamento em que foram desmontados.

De um lado do carter, insira a bússola de lubrificação dos rolamentos (pos. ①, Fig. 53), e um anel externo do rolamento (pos. ①, Fig. 54), mediante o uso de uma tampa e do mecanismo de percussão.

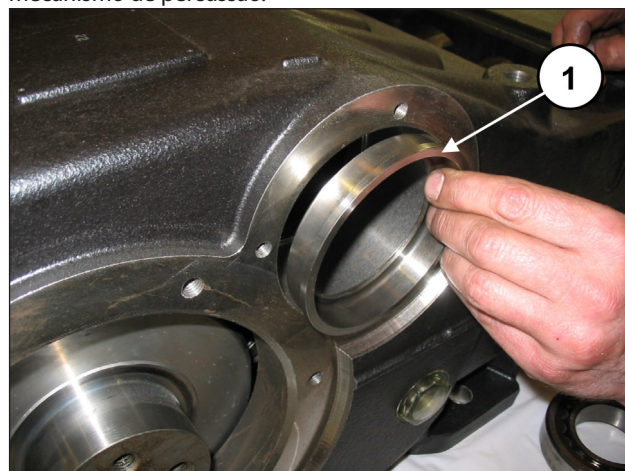

Fig. 53

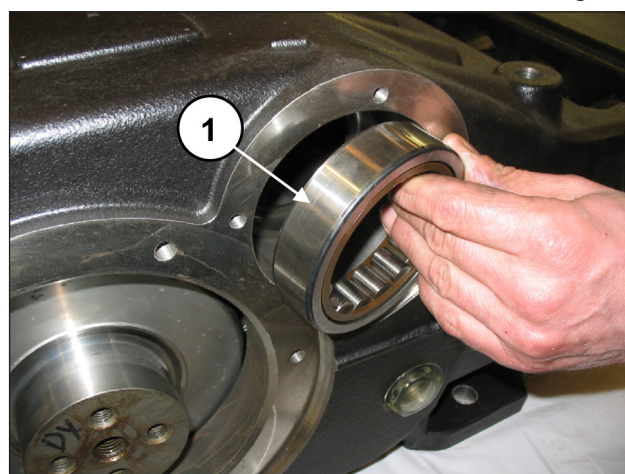

Fig. 54

Remove a ferramenta para o bloqueio da haste, cód. 27566200 (pos. ①, Fig. 40) e deslize as hastes para dentro até entrar em contato com o eixo de manivela.

Insira o eixo PTO pré-montado no interior do carter (pos. ①, Fig. 55), inserindo-o do lado oposto em que foram pré-montados no anel externo do rolamento e a bússola de lubrificação dos rolamentos.



A inserção do eixo PTO no carter deve ser efetuada, de modo que os dentes fiquem voltados como na Fig. 55.

Para agilizar a inserção completa do eixo PTO no interior do rolamento, use um parafuso M16 a aplicar na extremidade do eixo a ser inserido, com o objetivo de manter elevado o mesmo eixo (pos. ①, Fig. 56).

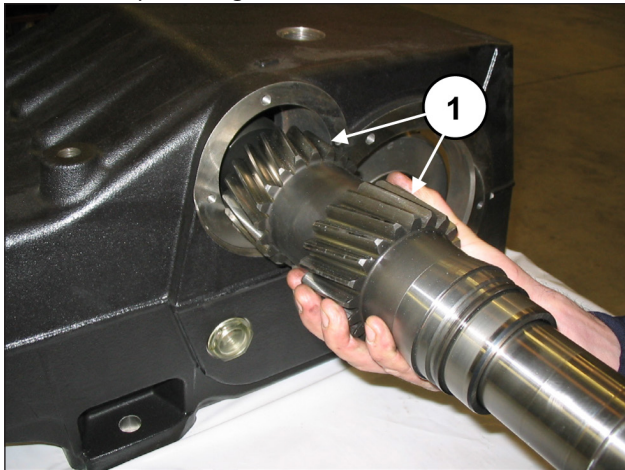

Fig. 55

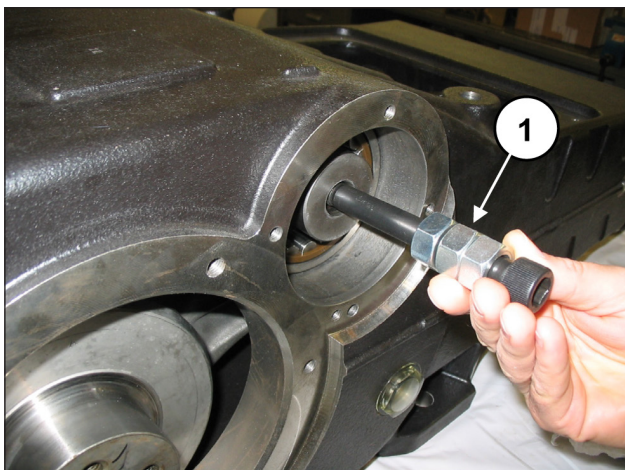

Fig. 56

Do lado em que é inserido o eixo PTO, proceda com a inserção da bússola de lubrificação dos rolamentos (pos. ①, Fig. 57), e de um anel externo do rolamento (pos. ①, Fig. 58), mediante o uso de uma tampa e do mecanismo de percussão.



Fig. 57

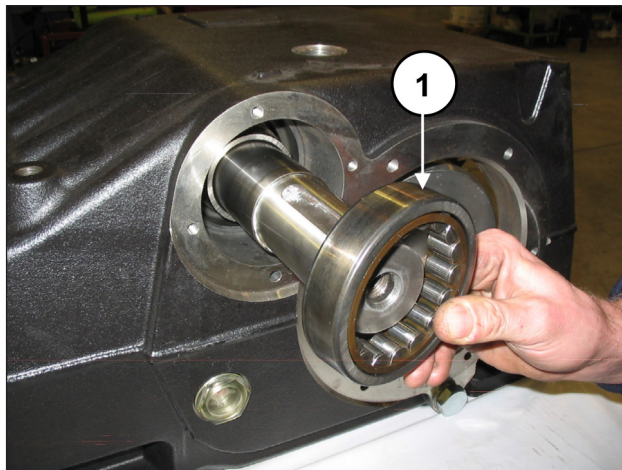

Fig. 58

Em ambos os lados, insira os espaçadores do rolamento interior (pos. ①, Fig. 59) e exterior (pos. ①, Fig. 60).

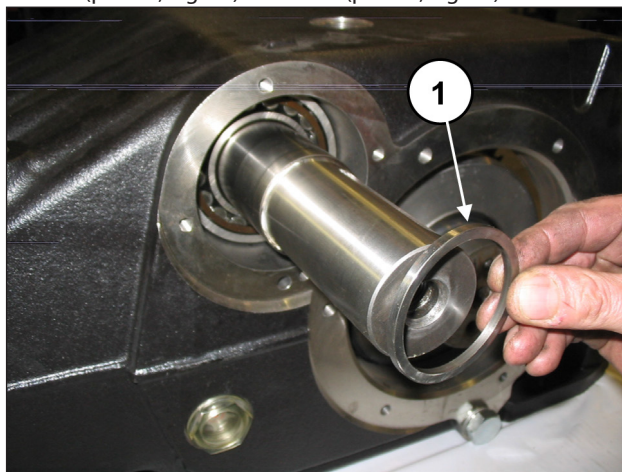

Fig. 59

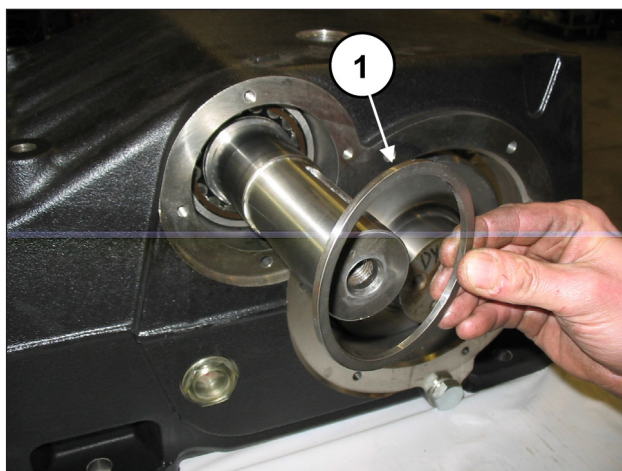

Fig. 60

Insira o anel interno (pos. ①, Fig. 61), e o anel externo (pos. ①, Fig. 62) de um rolamento de somente um lado da bomba.

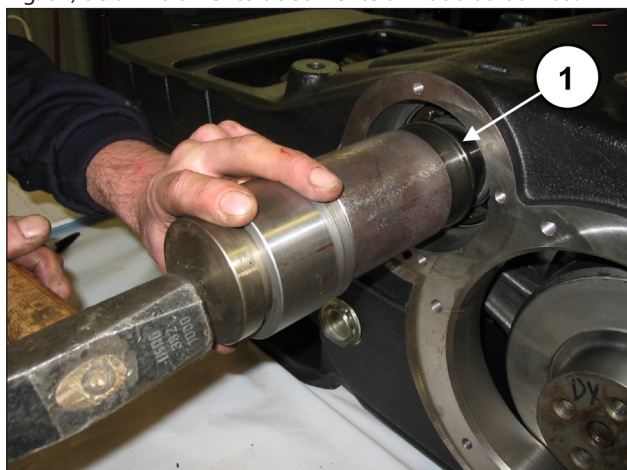

Fig. 61

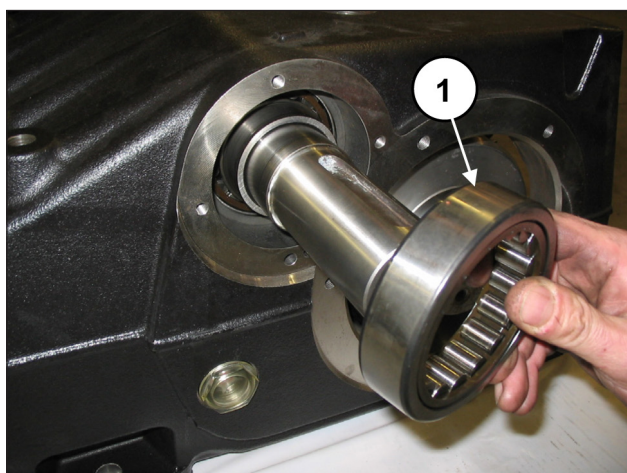

Fig. 62

Pré-monte as coberturas do rolamento PTO direito e esquerdo: Insira o anel de vedação radial no interior da cobertura do rolamento PTO, mediante o uso da ferramenta, cód. 27539500 (pos. ①, Fig. 63).

Antes de proceder com a montagem do anel de vedação radial, verifique as condições da borda de vedação. Se for necessária a substituição, posicione o novo anel, conforme indicado na Fig. 64.



Sempre que o eixo PTO apresentar um desgaste no diâmetro, em relação à borda de vedação, para evitar a operação de retificação, pode-se posicionar o anel na segunda passagem, conforme indicado na Fig. 64.

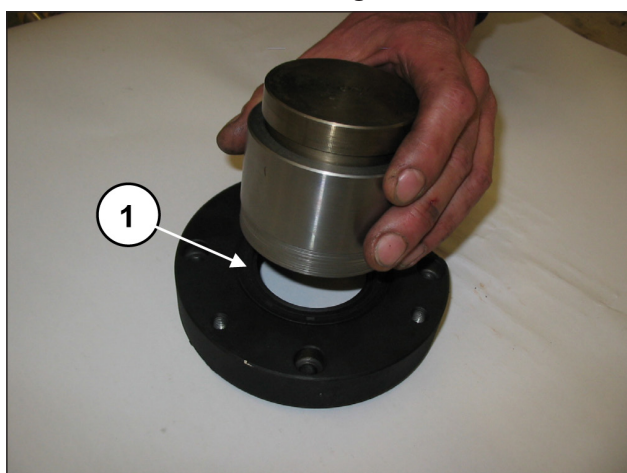

Fig. 63

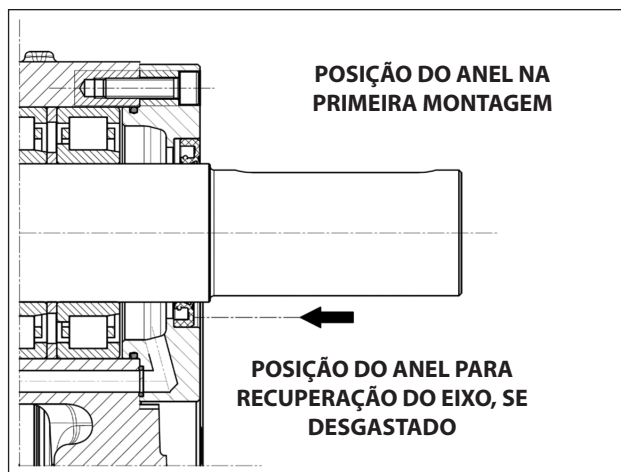

Fig. 64

Aplique o anel circular externo nas coberturas do rolamento PTO (pos. ①, Fig. 65), e o anel circular do furo de lubrificação (pos. ①, Fig. 66).

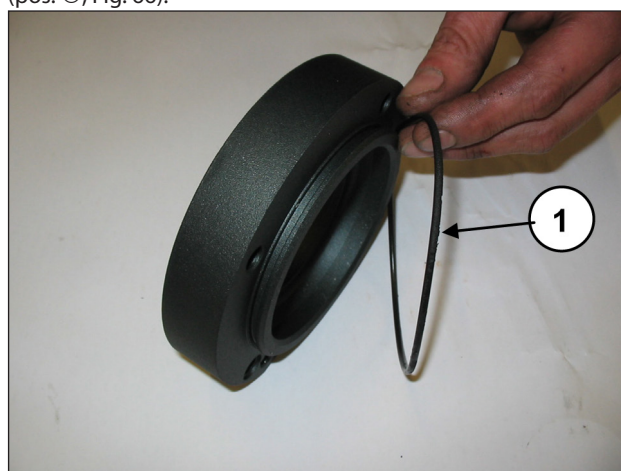

Fig. 65

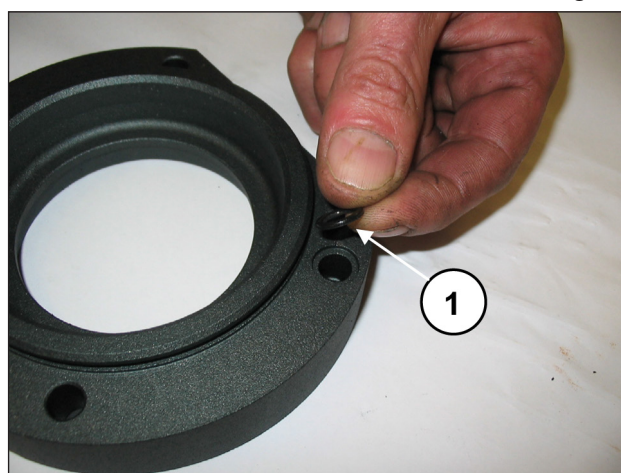

Fig. 66

Monte uma primeira cobertura do rolamento PTO (direito ou esquerdo) no carter da bomba (pos. ①, Fig. 67), e fixe-a mediante quatro parafusos M8x30 (pos. ①, Fig. 68).



Preste atenção para o sentido da montagem da cobertura da lubrificação da cobertura deve se encontrar em correspondência do furo no carter.

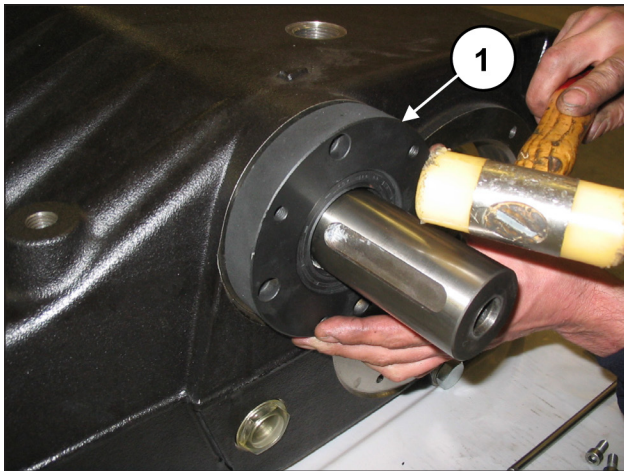

Fig. 67

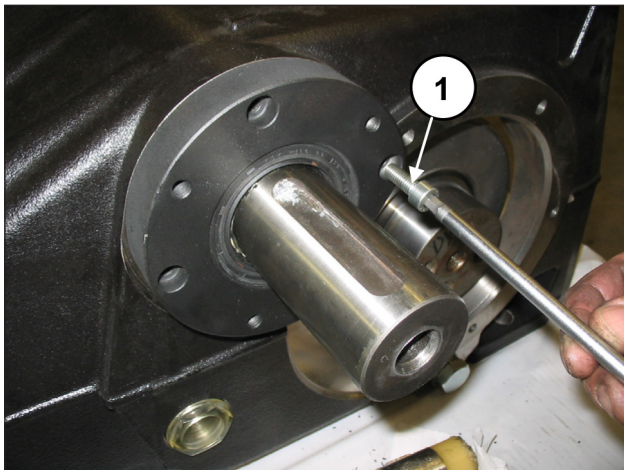

Fig. 68

Repita as operações do lado oposto:

Insira o anel interno (pos. ①, Fig. 61), e o anel externo (pos. ①, Fig. 62) do último rolamento.

Monte a cobertura do rolamento PTO que falta no carter da bomba (pos. ①, Fig. 67), e fixe-a mediante quatro parafusos M8x30 (pos. ①, Fig. 68).

Calibre os 4+4 parafusos com chave dinamométrica, conforme indicado no capítulo 3.

Pré-monte as duas coberturas porta-rolamento:

insira o rolamento, usando um mecanismo de percussão (pos. ①, Fig. 69), até obter uma cota de 4 ± 4.5 mm, conforme indicado na Fig. 70.



Fig. 69

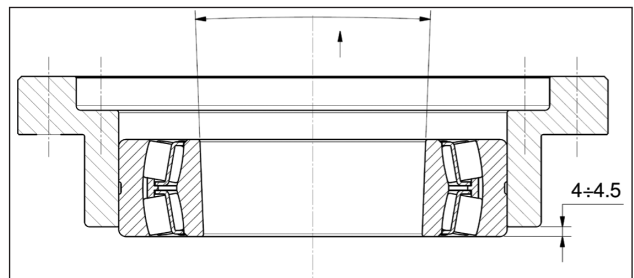

Fig. 70



O rolamento na Fig. 70 tem o anel interno cônico. Verifique se a conicidade esteja na parte interna para permitir a inserção seguinte da bússola.

Aplique o anel circular no exterior da cobertura do porta-rolamento (pos. ①, Fig. 71).

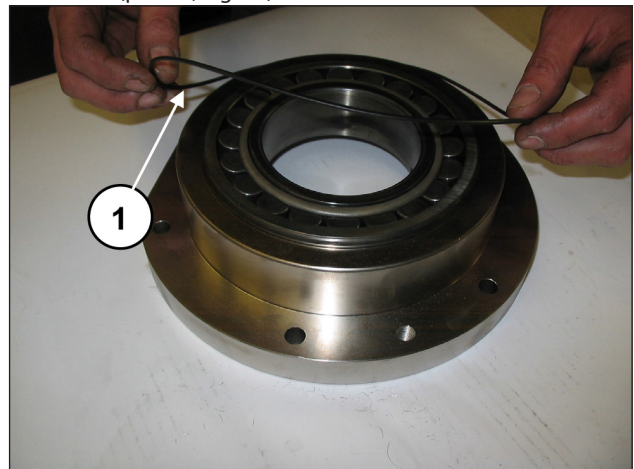

Fig. 71

Repita a operação com outra cobertura.
 Bloqueie os três grupos da haste, usando a ferramenta adequada, cód. 27566200 (pos. ①, Fig. 40).
 Aplique os dois pinos rosqueados M16 na extremidade do eixo de manivela e, mantendo-os elevados (pos. ①, Fig. 72), insira a cobertura do porta-rolamento completo do rolamento e do anel circular (pos. ①, Fig. 73), mediante o uso de um mecanismo de percussão. Repita a operação do lado oposto

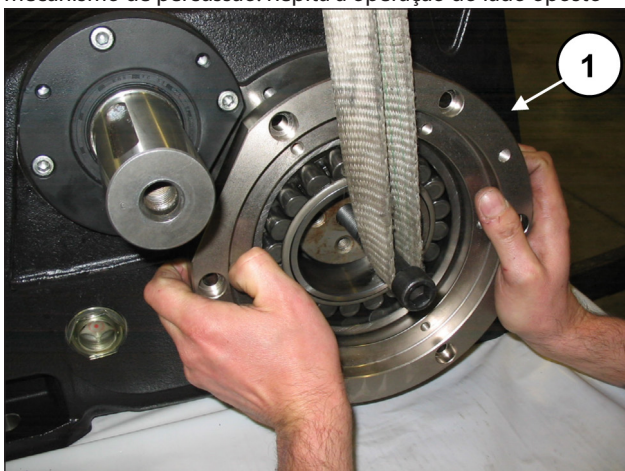

Fig. 72

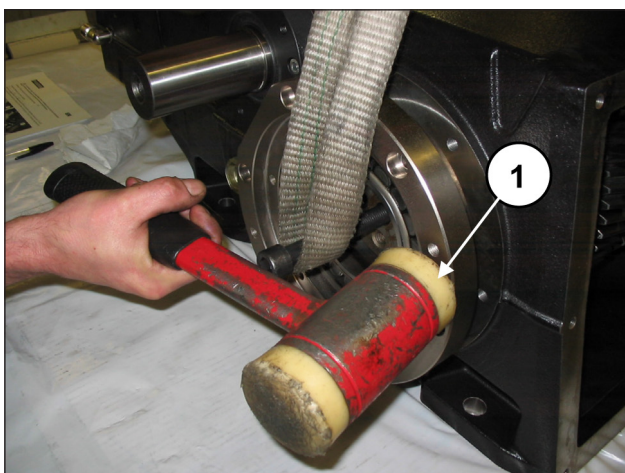

Fig. 73

Aperte as coberturas do porta-rolamento, mediante 6+6 parafusos M10x30 (pos. ①, Fig. 74).
 calibre os parafusos com chave dinamométrica, conforme indicado no capítulo 3.

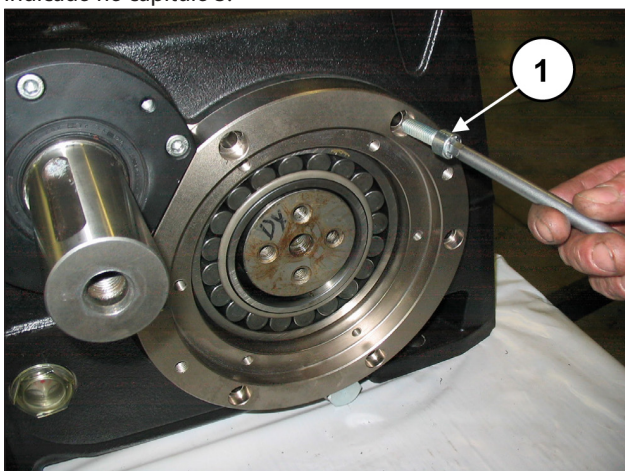

Fig. 74

Insira parcialmente as duas bússolas de pressão, mantendo o mecanismo de percussão elevado, mediante o pino M16 anteriormente montado (pos. ①, Fig. 75).

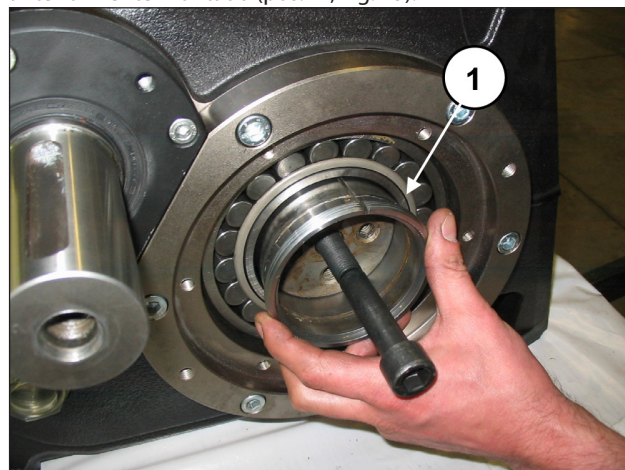

Fig. 75

Insira completamente a bússola de pressão no eixo de manivela (pos. ①, Fig. 76 e Fig. 77), mediante o uso de um mecanismo de percussão e de uma tampa.

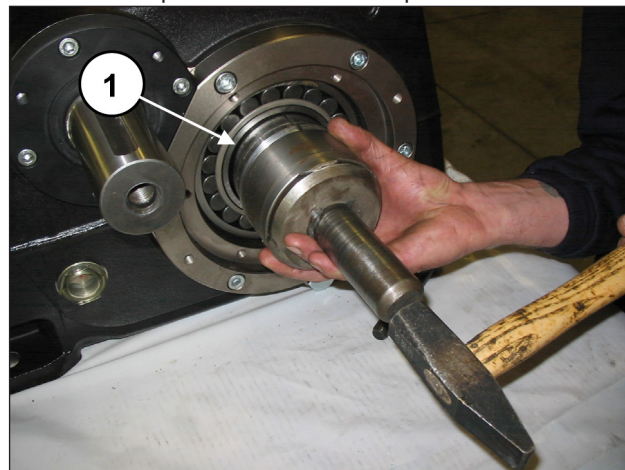

Fig. 76

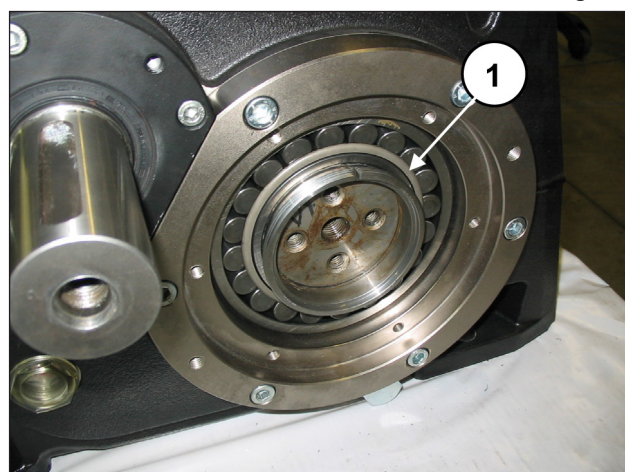

Fig. 77



A inserção da bússola de pressão deve ser realizada a seco (sem óleos ou lubrificantes).

Insira a bússola até que a superfície externa (cônica) se acople perfeitamente no interior do rolamento. Durante a inserção, certifique-se de que o rolamento permaneça em contato com o ombro do eixo de manivela.
 Repita a operação do lado oposto.

Insira a flange de bloqueio da bússola no interior das bússolas cônicas (pos. ①, Fig. 78).

Aplique um parafuso M16 de comprimento adequado (35-40 mm) no furo M16 do eixo de manivela e aperte até apoiar a flange contra a bússola (pos. ①, Fig. 79). Não aperte os parafusos.

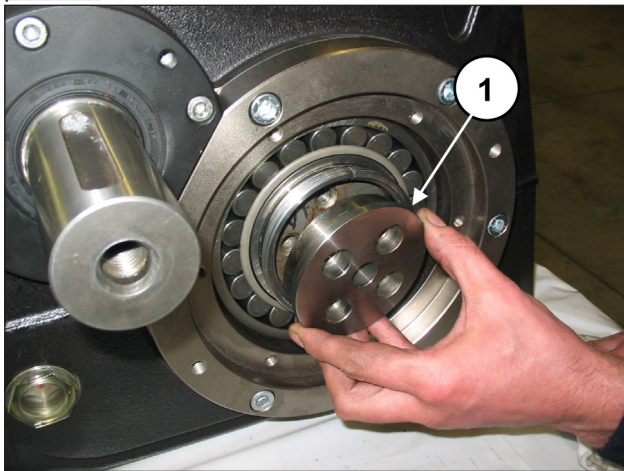

Fig. 78

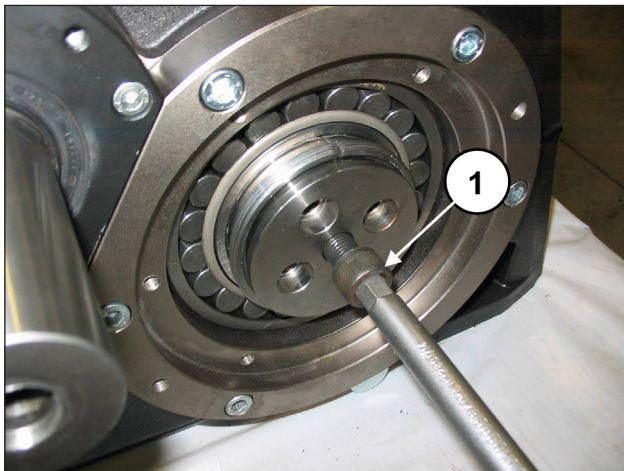

Fig. 79

Repita a operação do lado oposto.
Remova a ferramenta para o bloqueio da haste, cód. 27566200 (pos. ①, Fig. 40).
Insira os semi-rolamentos superiores entre as hastes e o eixo de manivela (pos. ①, Fig. 80).



Para uma montagem correta dos semi-rolamentos, certifique-se de que a lingueta de referência dos semi-rolamentos esteja posicionada na caixa adequada sobre a semi-haste (pos. ①, Fig. 81).

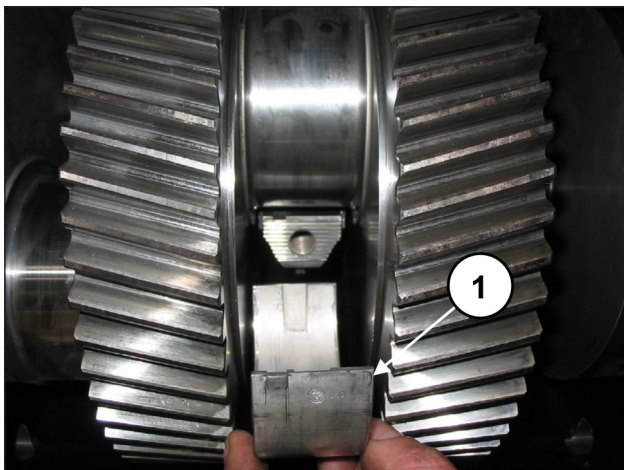

Fig. 80

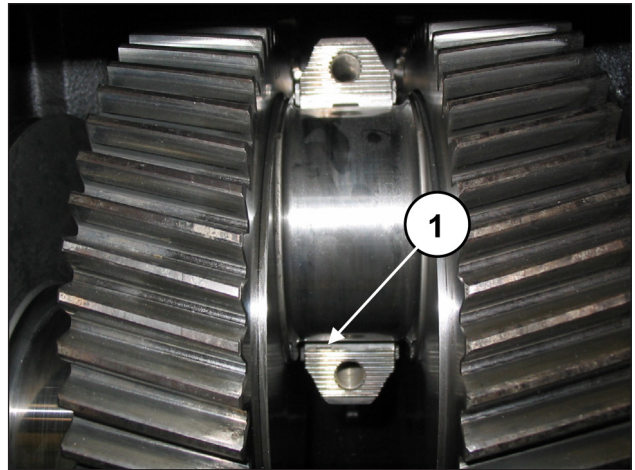

Fig. 81

Aplique os semi-rolamentos inferiores aos chapéus (pos. ①, Fig. 82), certificando-se que a lingueta de referência dos semi-rolamentos esteja posicionada na caixa sobre o chapéu (pos. ②, Fig. 82).

Fixe os chapéus nas semi-hastes mediante os parafusos M12x1.25x87 (pos. ①, Fig. 83).

Calibre os parafusos com chave dinamométrica, conforme indicado no capítulo 3, trazendo os parafusos ao torque de aperto simultaneamente.



Preste atenção na direção correta da montagem dos chapéus. A numeração deve ser virada para cima.

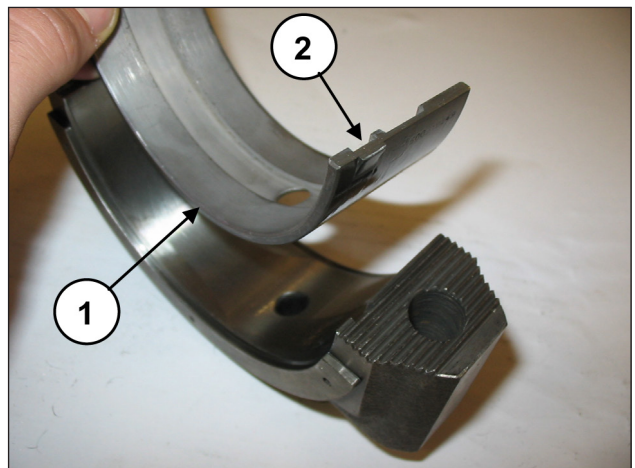

Fig. 82

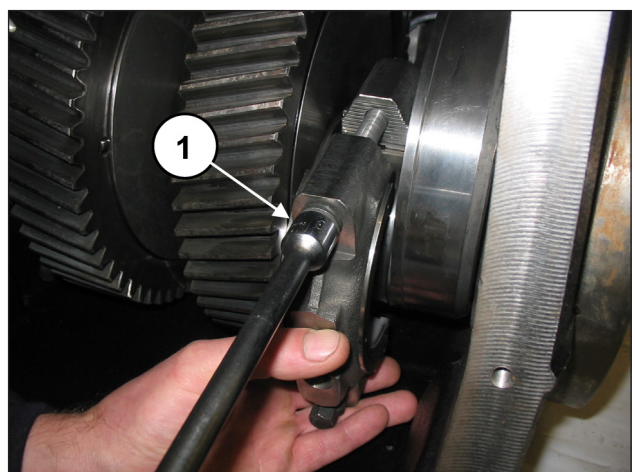

Fig. 83



Com a operação concluída, verifique se as hastes tenham uma folga axial em todas as direções.

Insira uma espessura sob o corpo da haste central para bloquear a rotação do eixo de manivela (pos. ①, Fig. 84).

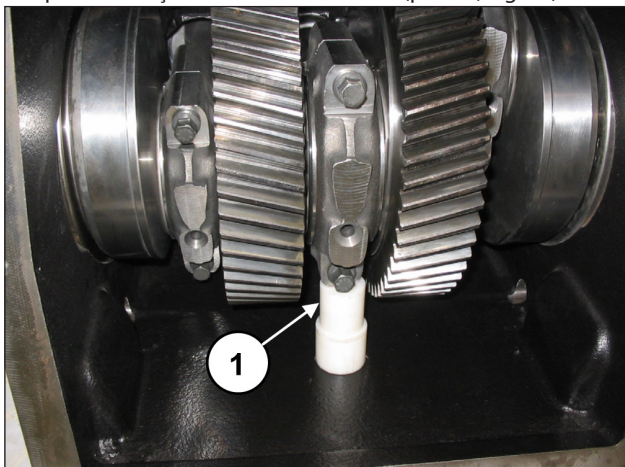

Fig. 84

Meça a cota "X", indicada na Fig. 85 entre a bússola cônica e o rolamento do eixo de manivela.

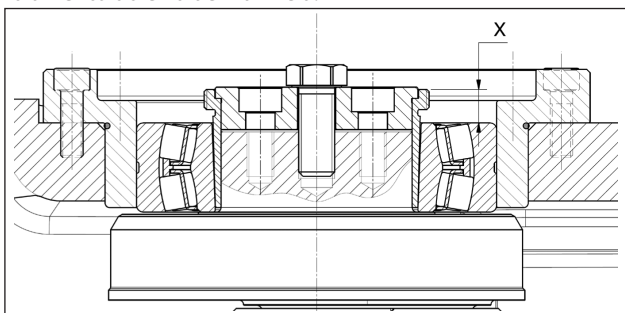

Fig. 85

Solte o parafuso M16, até determinar uma redução da cota "X", entre 0.7 e 0.8 mm (Fig. 86).

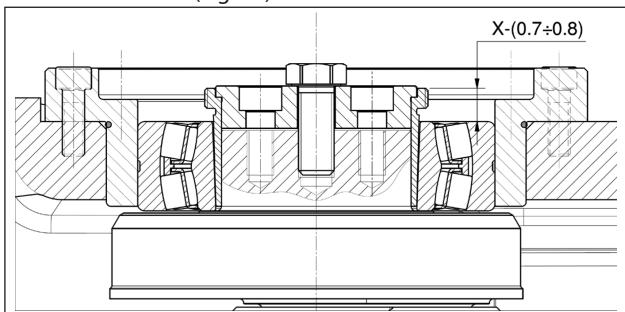

Fig. 86

Repita a operação do lado oposto.

Remova o parafuso M16 do eixo de manivela.

Solte as duas flanges de bloqueio do eixo de manivela, mediante 4+4 M12x25 (pos. ①, Fig. 88).



Aplique o LOCTITE 243 nas roscas dos parafusos M12x25 (pos. ①, Fig. 87).

Calibre os parafusos com chave dinamométrica, conforme indicado no capítulo 3.

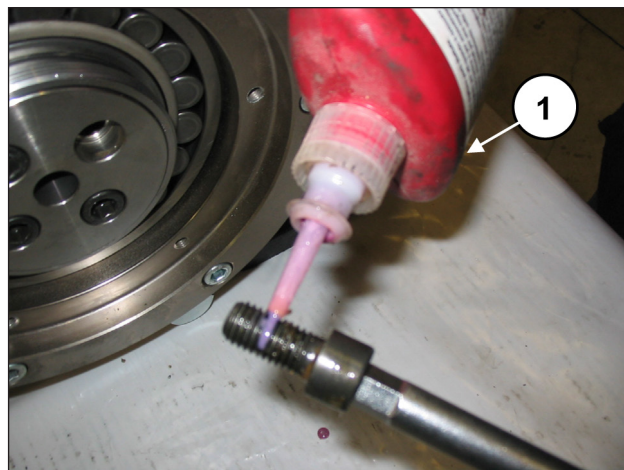

Fig. 87

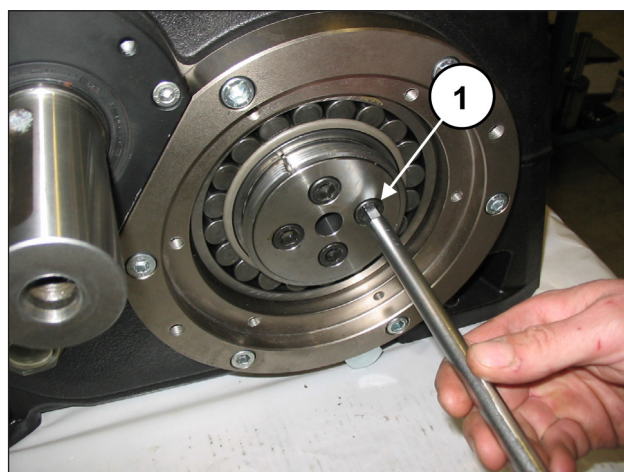

Fig. 88

Remova a espessura anti-rotação sob o corpo da haste central. Monte as duas coberturas do rolamento (com anel circular relativo) (pos. ①, Fig. 89), mediante 6+6 parafusos M8x20 (pos. ①, Fig. 90).

Calibre os parafusos com chave dinamométrica, conforme indicado no capítulo 3.

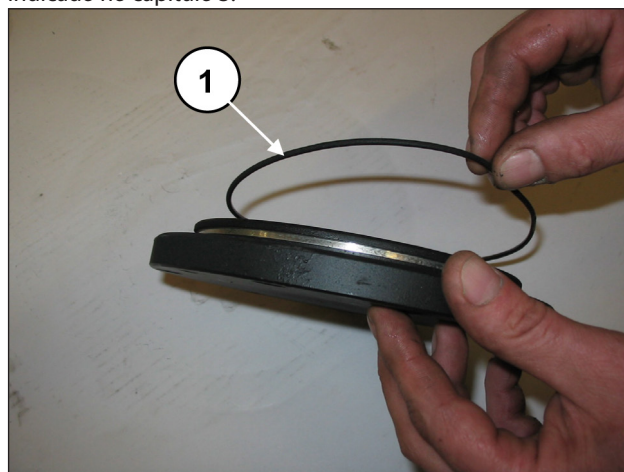

Fig. 89

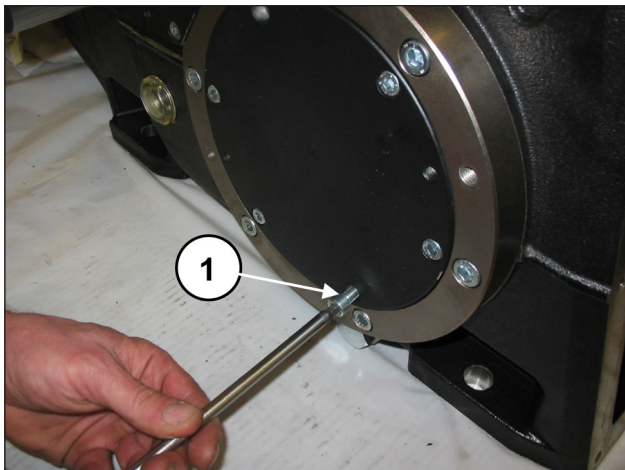

Fig. 90

Insira o anel circular na cobertura posterior (pos. ①, Fig. 91), e fixe-os no carter, mediante 10 parafusos M8x20 (pos. ①, Fig. 92).

Calibre os parafusos com chave dinamométrica, conforme indicado no capítulo 3.

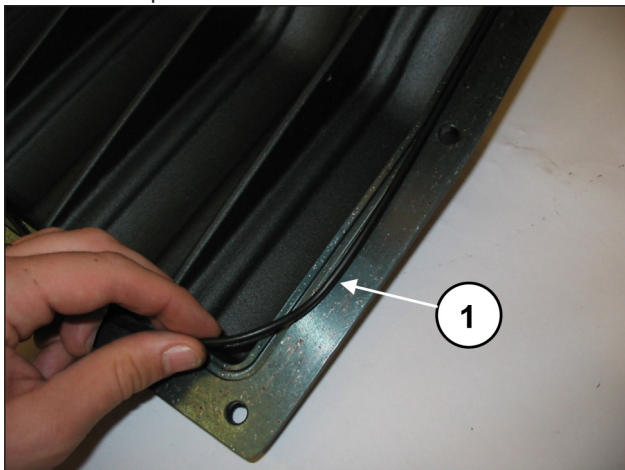

Fig. 91

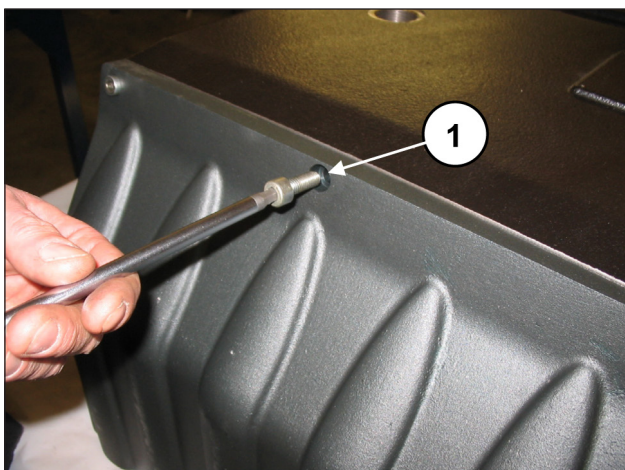

Fig. 92

Monte o anel de vedação radial na cobertura da vedação do óleo (pos. ①, Fig. 93), mediante o uso de uma tampa, cód. 27910900.

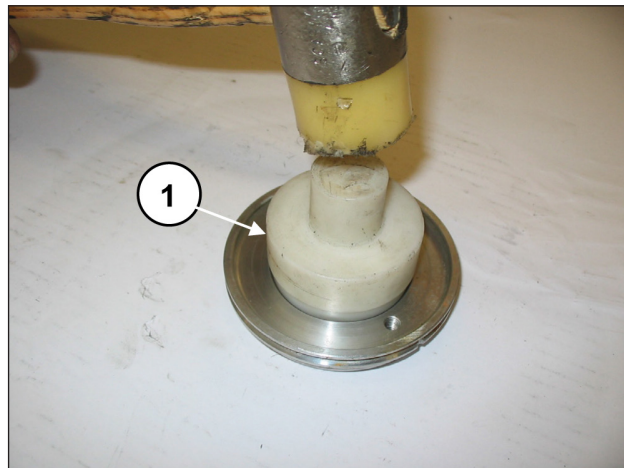

Fig. 93

Posicione o anel circular (pos. ①, Fig. 94) no local da cobertura da vedação do óleo.

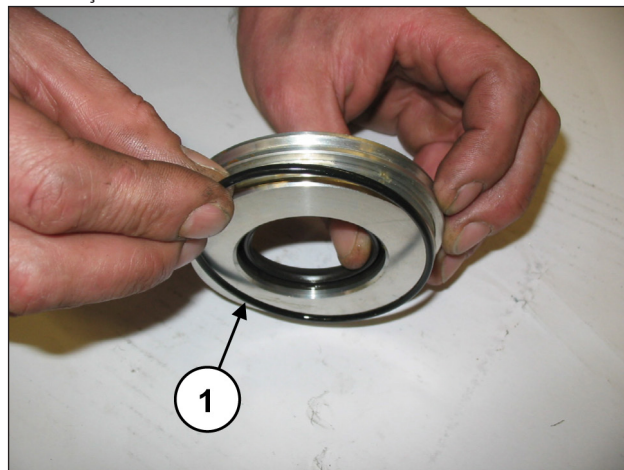

Fig. 94

Insira o grupo montado no interior do carter no local adequado, certificando-se de que a cobertura entre completamente no local (pos. ①, Fig. 95), prestando atenção para não danificar a borda do anel de vedação radial. Solte as coberturas da vedação do óleo, mediante dois grãos M6x30 (pos. ①, Fig. 96).

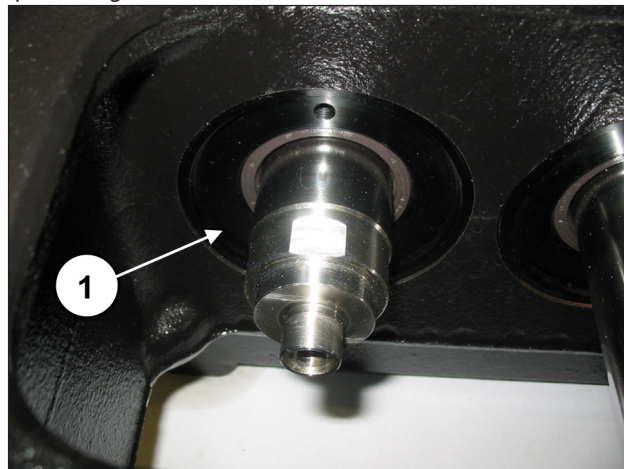

Fig. 95

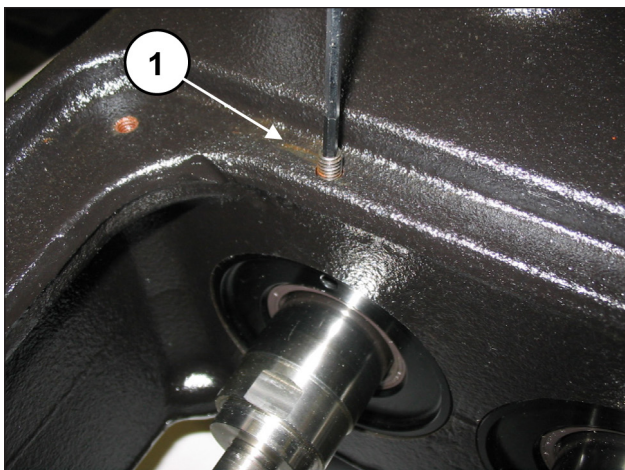

Fig. 96

Calibre os parafusos com chave dinamométrica, conforme indicado no capítulo 3.
 Posicione as proteções contra respingos e o anel espaçador das proteções contra respingos no local sobre a haste da guia do pistão (pos. ①, Fig. 97 e Fig. 98).

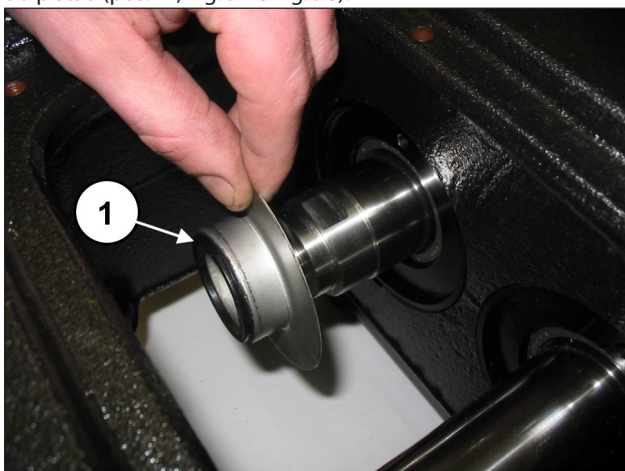

Fig. 97

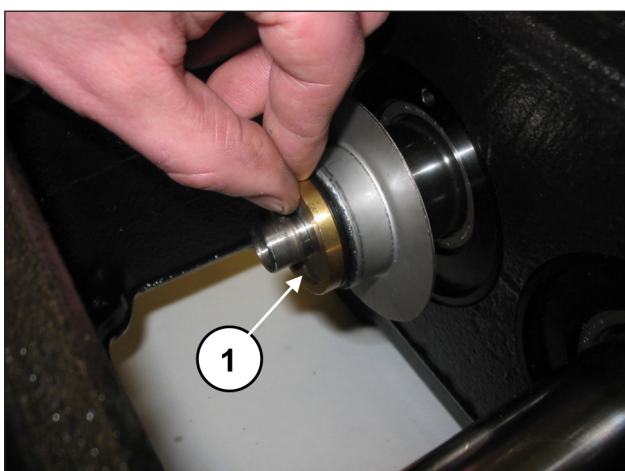

Fig. 98

Nas duas coberturas, inspecione a inserção do anel circular (pos. ①, Fig. 99) e monte as coberturas mediante o uso de 4+4 parafusos M6x14 (pos. ①, Fig. 100).

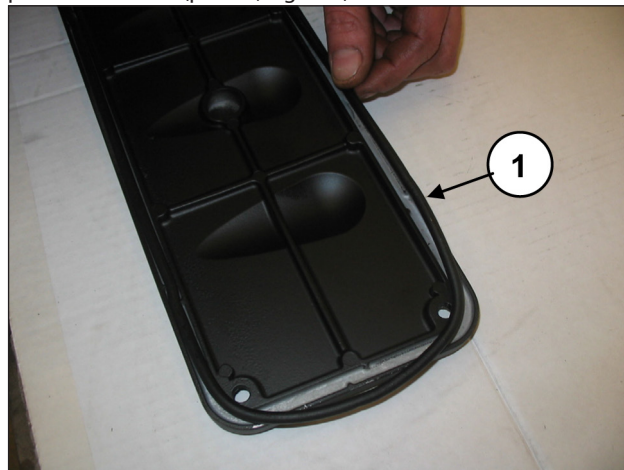

Fig. 99

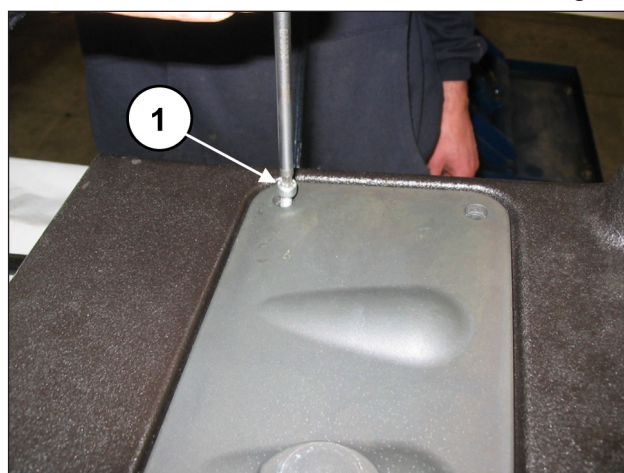

Fig. 100

Calibre os parafusos com chave dinamométrica, conforme indicado no capítulo 3 "Calibragem de aperto dos parafusos".
 Monte a cobertura da extremidade do eixo e fixe-a no carter, mediante três parafusos M8x20 (pos. ①, Fig. 101).
 Calibre os parafusos com chave dinamométrica, conforme indicado no capítulo 3 "Calibragem de aperto dos parafusos".



Fig. 101

Aplique a lingueta no eixo do PTO (pos. ①, Fig. 102).

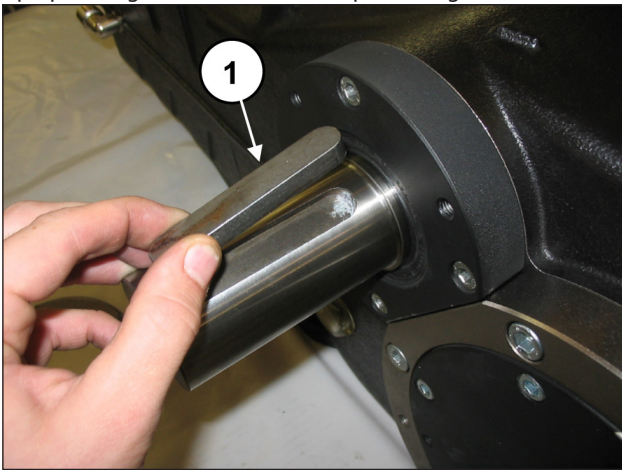

Fig. 102

2.1.3 Classes de aumento previstas

TABELA DE AUMENTO PARA O EIXO DE MANIVELA E SEMI-ROLAMENTOS DA HASTE			
Classe de recuperação (mm)	Código do semi-rolamento superior	Código do semi-rolamento inferior	Correção do diâmetro do pino do eixo (mm)
0.25	90931100	90930100	Ø92.75 0/-0.03 Ra 0.4 Rt 3.5
0.50	90931200	90930200	Ø92.50 0/-0.03 Ra 0.4 Rt 3.5

TABELA DE AUMENTO PARA O CARTER DA BOMBA E GUIA DO PISTÃO		
Classe de recuperação (mm)	Código da guia do pistão	Correção do local do carter da bomba (mm)
1.00	79050543	Ø81 H6 +0.022/0 Ra 0.8 Rt 6

2.2 REPARAÇÃO DA PARTE HIDRÁULICA

2.2.1 Desmontagem do cabeçote - grupos da válvula

O cabeçote precisa de uma manutenção preventiva, conforme indicado no *Manual de uso e manutenção*.

As intervenções são limitadas à inspeção ou substituição da válvula, quando necessário.

Para a extração dos grupos da válvula, opere como mostra a seguir:

Solte o dispositivo de abertura da válvula mediante chave de 30 mm (cód. ①, Fig. 103).

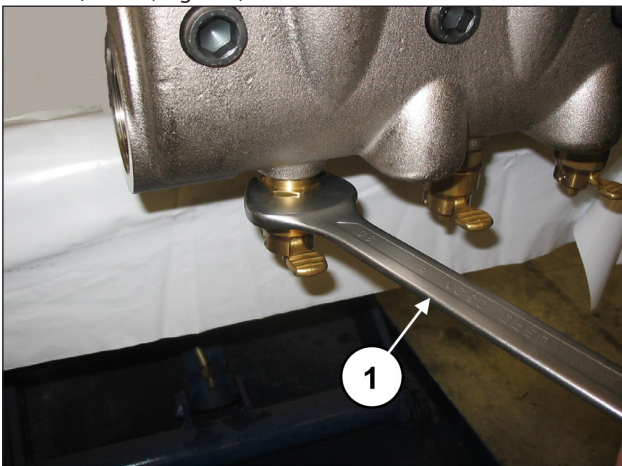

Fig. 103

Aplique dois suportes com rosqueamento G2" nos engates de fluxo do cabeçote (pos. ①, Fig. 104) e, em seguida, solte os oito parafusos M16x150 (pos. ①, Fig. 105). Preste atenção para não bater os pistões durante a extração do cabeçote.

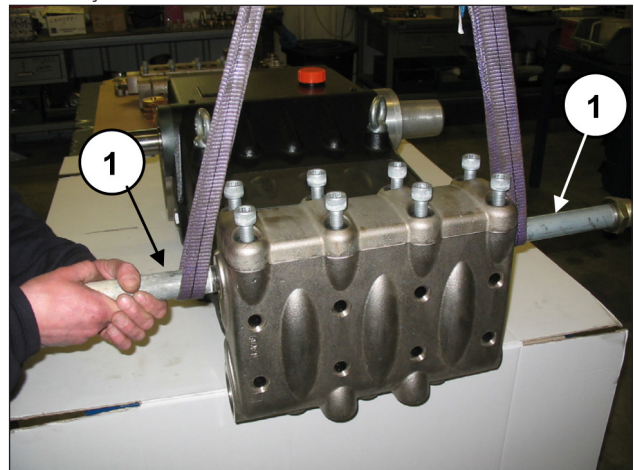

Fig. 104

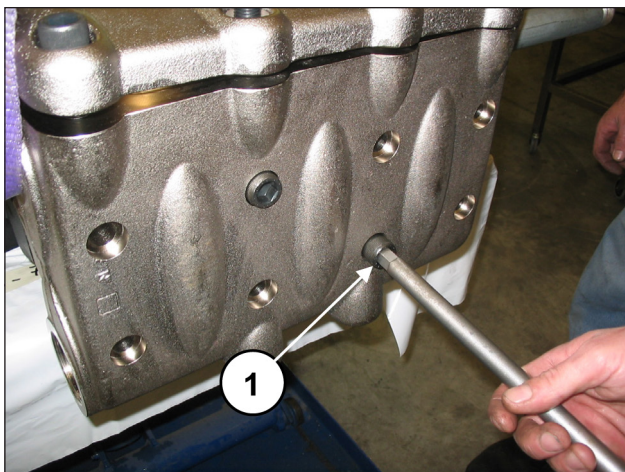

Fig. 105

Extraia os oito parafusos M16x55 da cobertura da válvula (pos. ①, Fig. 106), e remova a cobertura (pos. ①, Fig. 107).

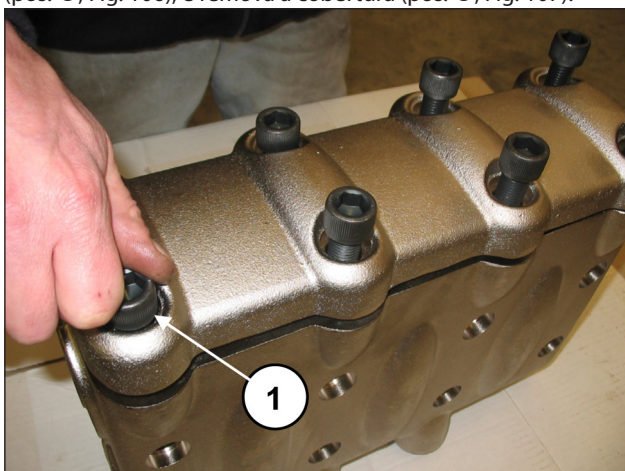

Fig. 106

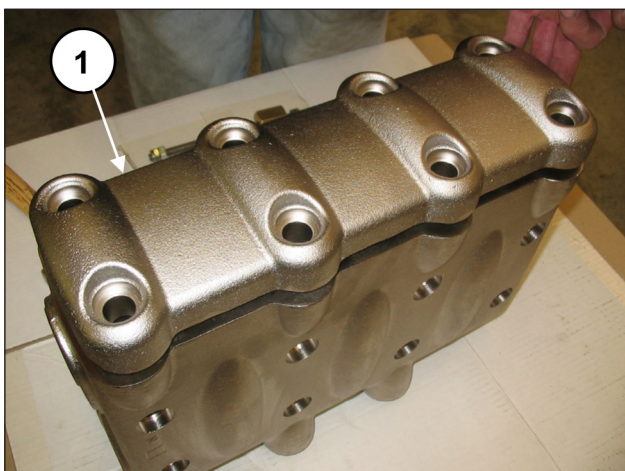

Fig. 107

Extraia a tampa da válvula com o uso de um extrator de mecanismo de percussão para aplicar o furo M10 da tampa da válvula (pos. ①, Fig. 108).

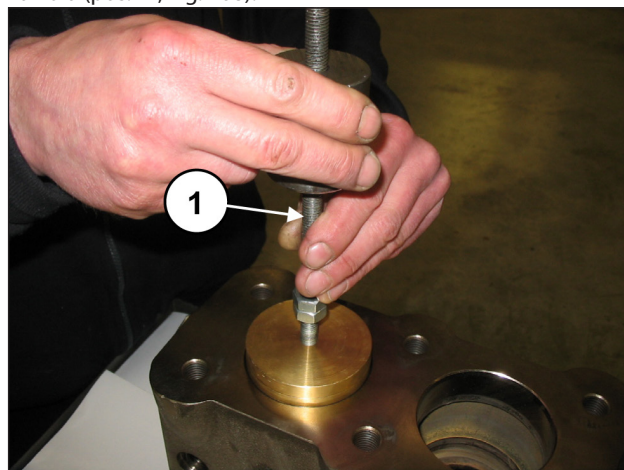

Fig. 108

Solte a mola (pos. ①, Fig. 109).

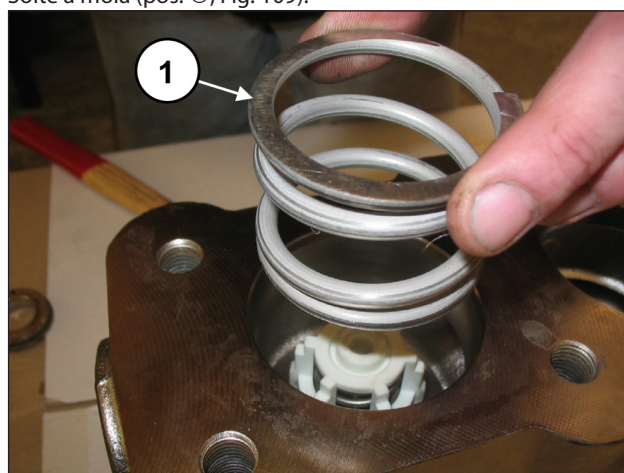

Fig. 109

Extraia o grupo da válvula de fluxo, mediante o uso de um extrator de mecanismo de percussão, para aplicar no furo M10 da guia da válvula (pos. ①, Fig. 110).

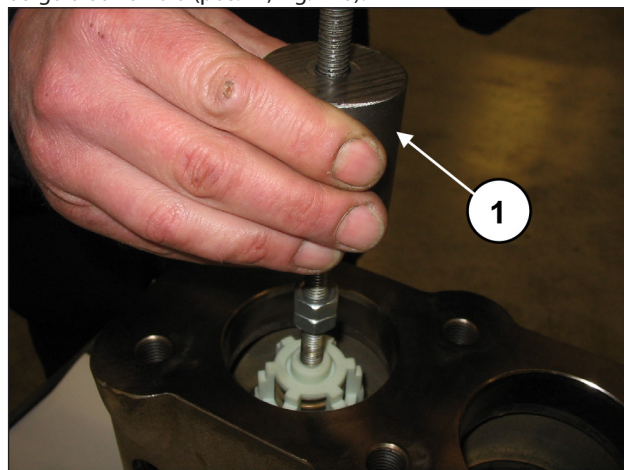

Fig. 110



Se a extração do grupo da válvula de fluxo permanecer particularmente difícil (por ex., para incrustações devido a uma inutilização prolongada da bomba), use a ferramenta do extrator, cód. 27516400.

Extraia o espaçador da guia da válvula, mediante o uso de uma chave hexagonal de 8 mm (pos. ①, Fig. 111).

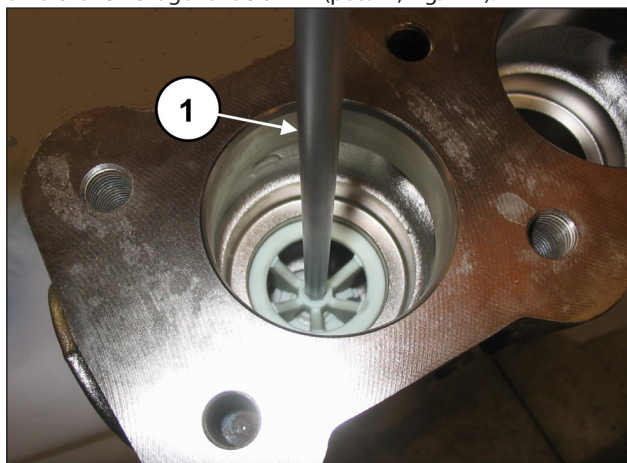

Fig. 111

Extraia o grupo da válvula de aspiração, mediante o uso de um extrator de mecanismo de percussão, para aplicar no furo M10 da guia da válvula (pos. ①, Fig. 112).

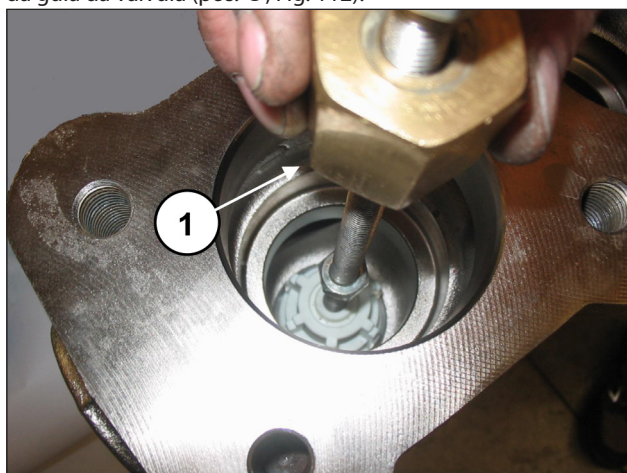

Fig. 112



Se a extração do grupo da válvula de aspiração resultar particularmente difícil (por ex., para incrustação devido a uma inutilização prolongada da bomba) use a ferramenta do extrator, cód. 27516200 (para LK36-LK40-LK45) ou o cód. 27516300 (para LK50-LK55-LK60) (pos. ①, Fig. 113) e atue conforme indicado.

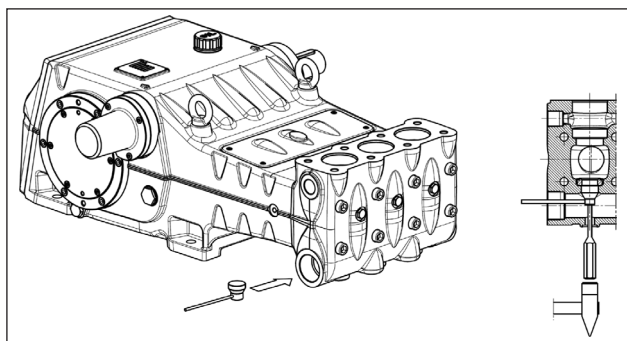

Fig. 113

Desmonte os grupos da válvula de aspiração e de fluxo, soltando um parafuso M10 de modo a pressionar na guia interna e extrair a guia da válvula do local da válvula (pos. ①, Fig. 114).

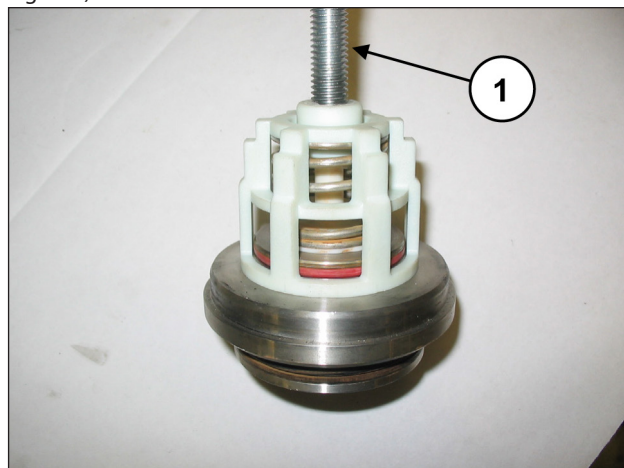

Fig. 114

2.2.2 Montagem do cabeçote - grupos da válvula



Preste atenção especial ao estado de desgaste dos vários componentes e substitua-os, quando necessário.

A cada inspeção da válvula, substitua todos os anéis circulares, seja dos grupos ou das tampas da válvula.



Antes de reposicionar os grupos da válvula, limpe e enxugue perfeitamente as relativas ranhuras no cabeçote, indicadas pela seta (pos. ①, Fig. 115).

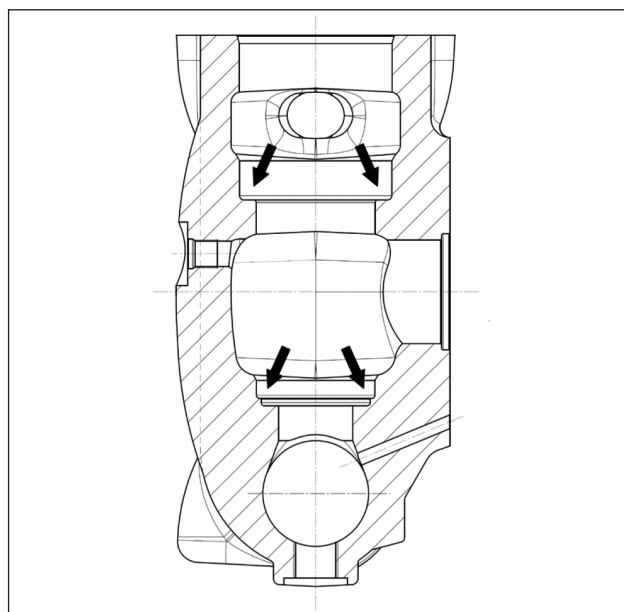

Fig. 115

Proceda com a remontagem, seguindo o procedimento inverso da remontagem indicada no parág. 2.2.1.

Monte os grupos da válvula de aspiração e de fluxo (Fig. 116 e Fig. 117) preste atenção para não inverter as molas anteriormente desmontadas.
 Para facilitar a inserção da guia da válvula no local, pode-se usar um tubo que apoie as placas horizontais da guia (Fig. 118) e usar um mecanismo de percussão, agindo em toda a circunferência



Fig. 116

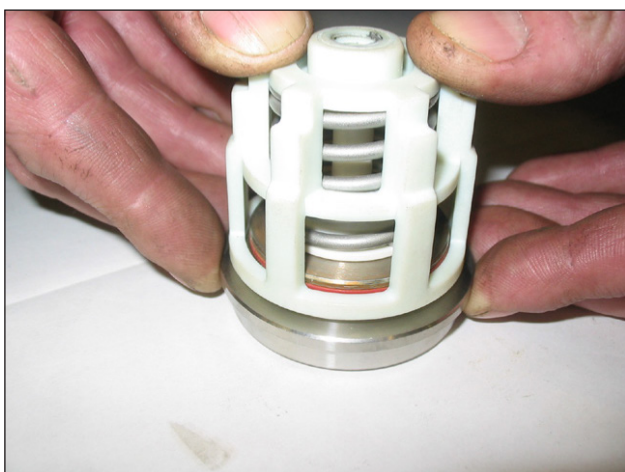

Fig. 117

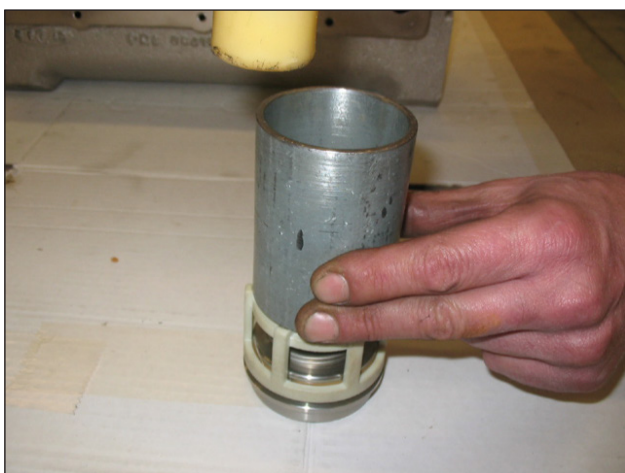

Fig. 118



Proceda com a inserção dos grupos da válvula (aspiração e de fluxo) no cabeçote, prestando atenção à sequência correta da inserção dos anéis circulares e dos anéis de anti-extrusão.

A sequência correta de montagem dos grupos da válvula no cabeçote é a seguinte:

Insira o anel anti-extrusão, pos. de explosão nº. 4 (pos. ①, Fig. 119).

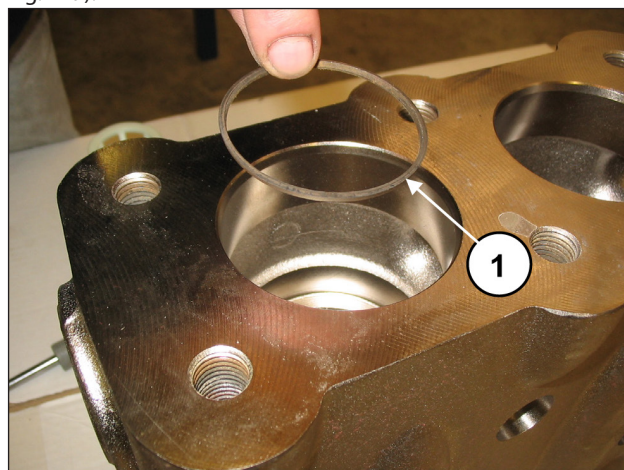

Fig. 119

Insira o anelo circular, pos. de explosão nº. 5 (pos. ①, Fig. 120).

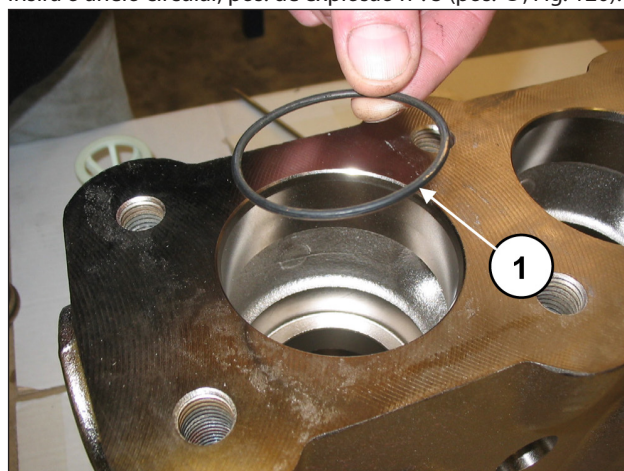

Fig. 120

Verifique se o anel circular e o anel de anti-extrusão ficaram perfeitamente no local.

Insira o grupo da válvula de aspiração (pos. ①, Fig. 121) e sucessivamente o espaçador (pos. ①, Fig. 122).

O grupo da válvula completo deve ser inserido completamente no fundo e apresentar-se como na pos. ①, Fig. 122.

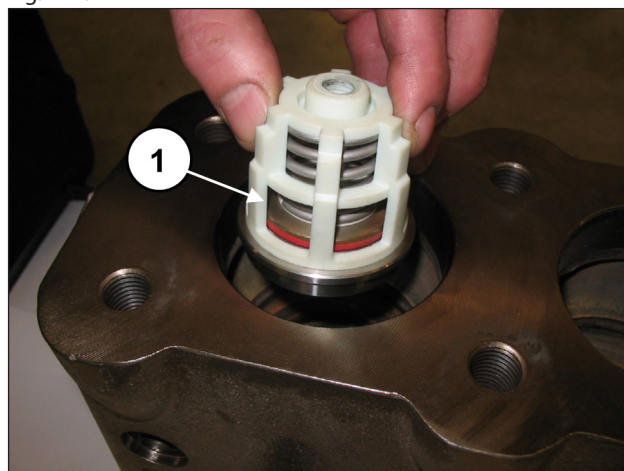

Fig. 121

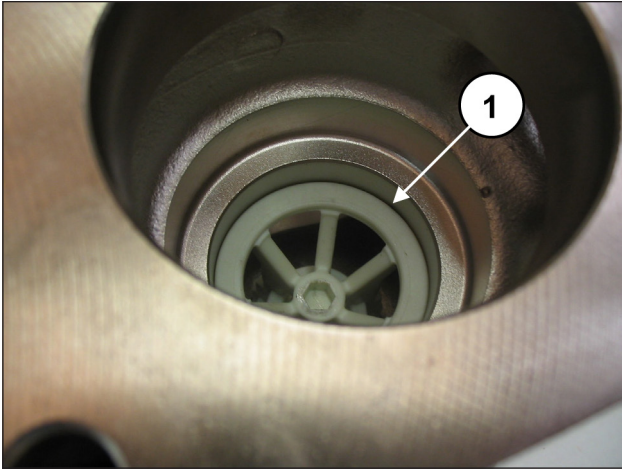

Fig. 122

Monte o anel circular, pos. de explosão nº. 5 (pos. ①, Fig. 123) e o anel anti-extrusão, pos. de explosão nº. 15 (pos. ②, Fig. 123) sobre o local da válvula de fluxo.

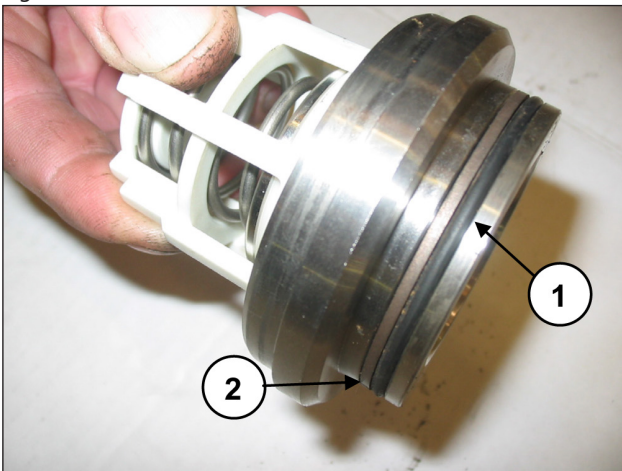

Fig. 123

Insira o grupo da válvula de fluxo (pos. ①, Fig. 124). O grupo da válvula deve ser inserido completamente no fundo e apresentar-se como na pos. ①, Fig. 125.

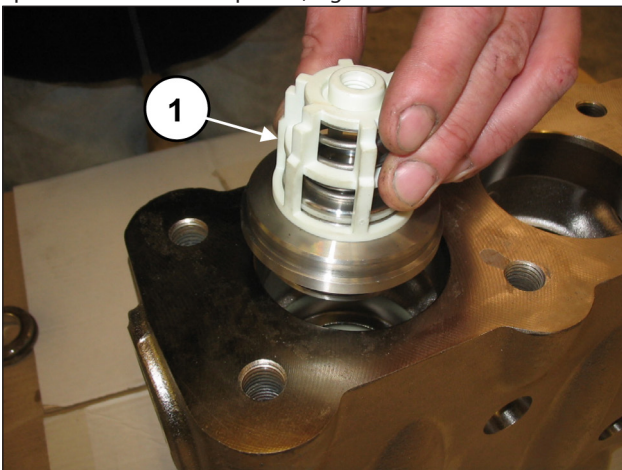

Fig. 124

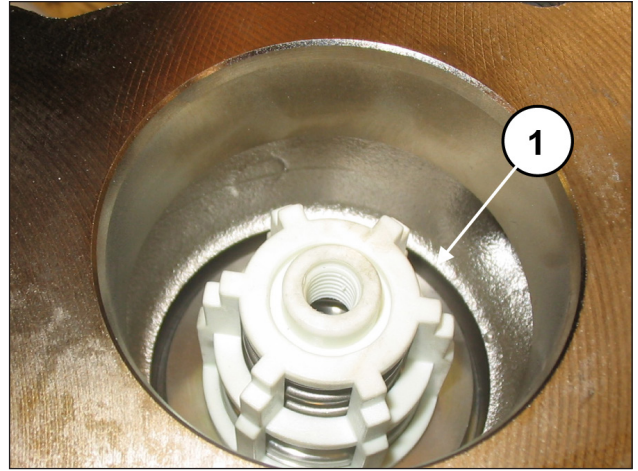

Fig. 125

Insira o anel anti-extrusão, pos. de explosão nº. 16 (pos. ①, Fig. 126).

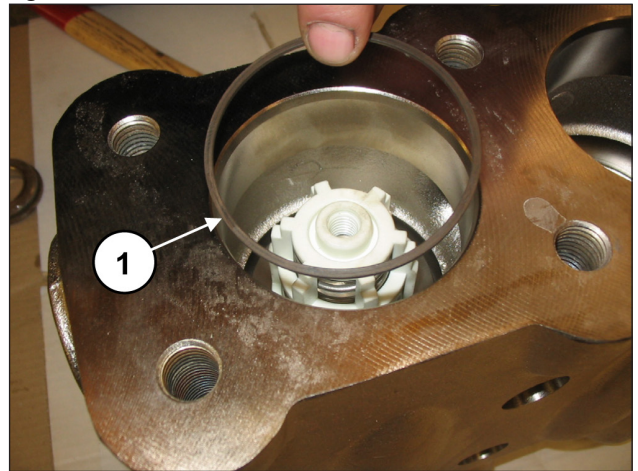

Fig. 126

Insira o anelo circular, pos. de explosão nº. 17 (pos. ①, Fig. 127).

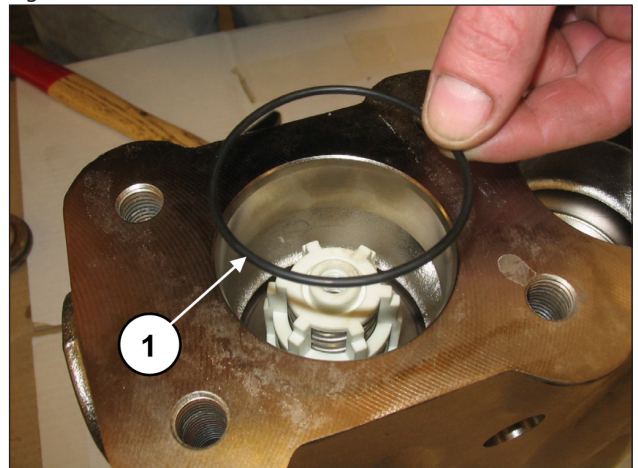

Fig. 127



Preste atenção especial na inserção do anel circular indicado na pos. ①, Fig. 128. Aconselha-se o uso da ferramenta cod. 27516000 (para LK36-LK40-LK45) ou o cód. 27516100 (para LK50-LK55-LK60), para evitar que o anel circular possa cortar durante a inserção.

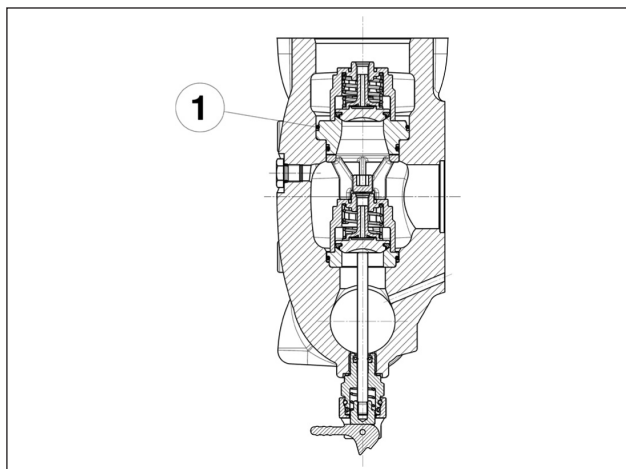

Fig. 128

Insira o anel do local da válvula (pos. ①, Fig. 129) e a mola (pos. ①, Fig. 130).

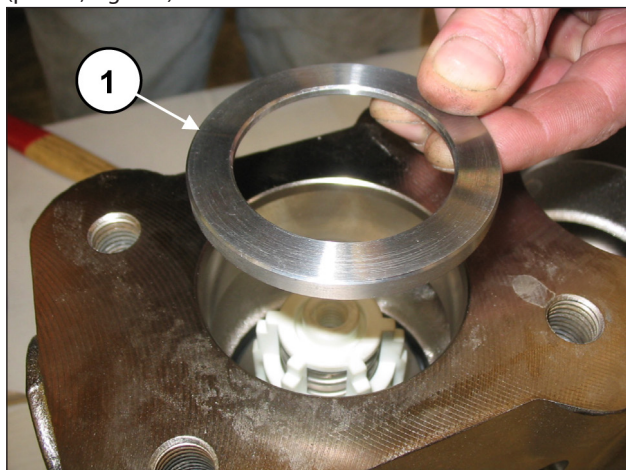

Fig. 129

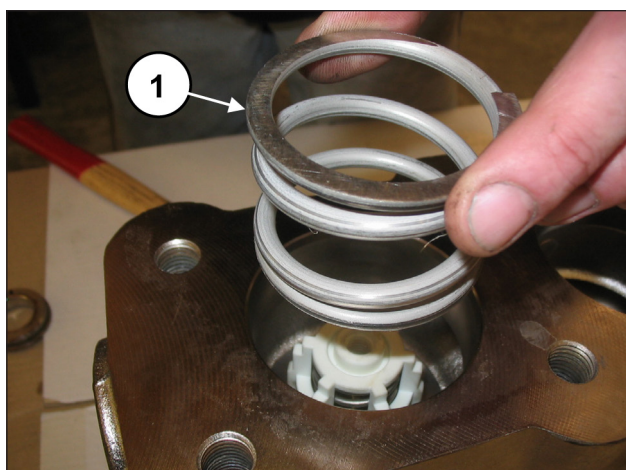

Fig. 130

Monte o anel circular, pos. de explosão nº. 17 (pos. ①, Fig. 131) e o anel anti-extrusão, pos. de explosão nº. 21 (pos. ②, Fig. 131) na tampa da válvula de fluxo.

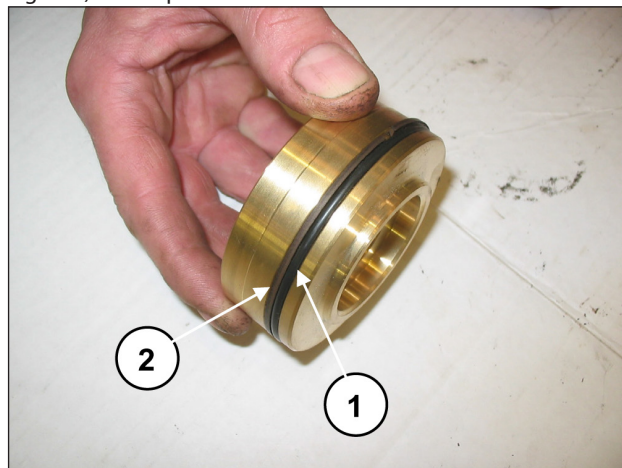

Fig. 131

Insira a tampa da válvula completa com o anel circular e anéis anti-extrusão.

Depois de ter terminado com a montagem dos grupos da válvula e da tampa da válvula, aplique a cobertura da válvula (pos. ①, Fig. 132) e solte os oito parafusos M16x55 (pos. ①, Fig. 133).

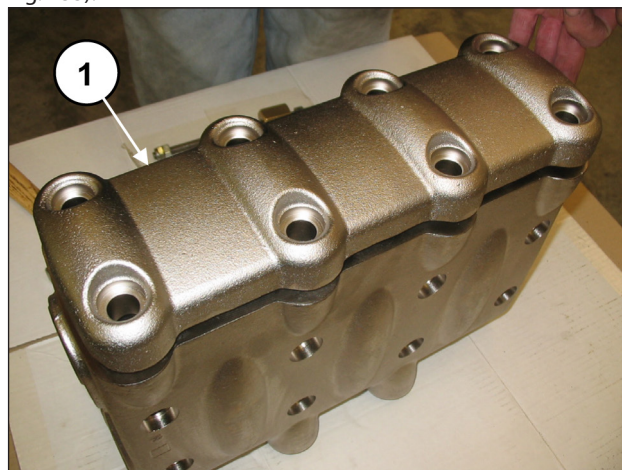

Fig. 132

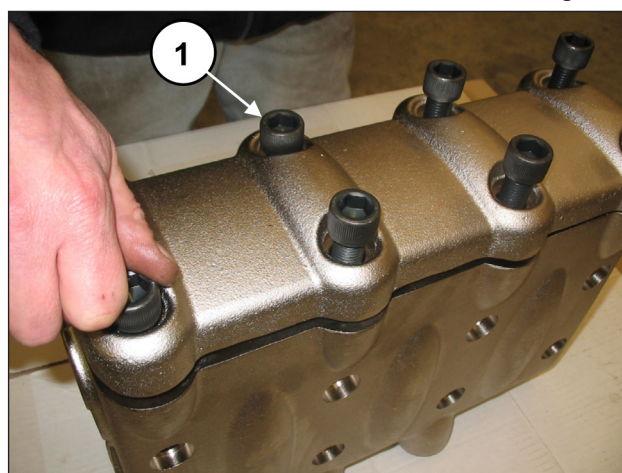

Fig. 133

Monte o cabeçote no carter da bomba (pos. ①, Fig. 134), prestando atenção para não bater os pistões e soltar os oito parafusos M16x150 (pos. ①, Fig. 135).

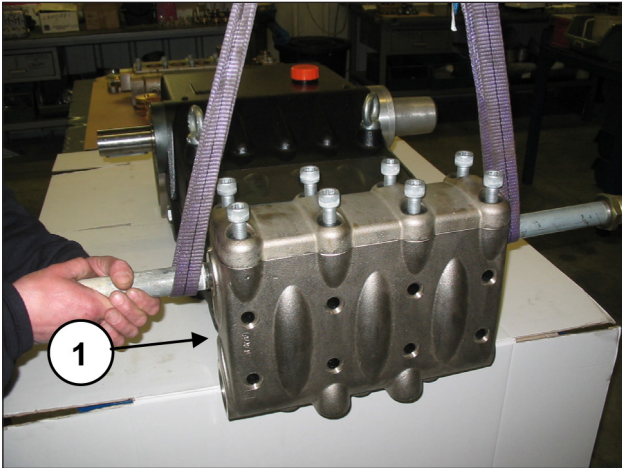

Fig. 134

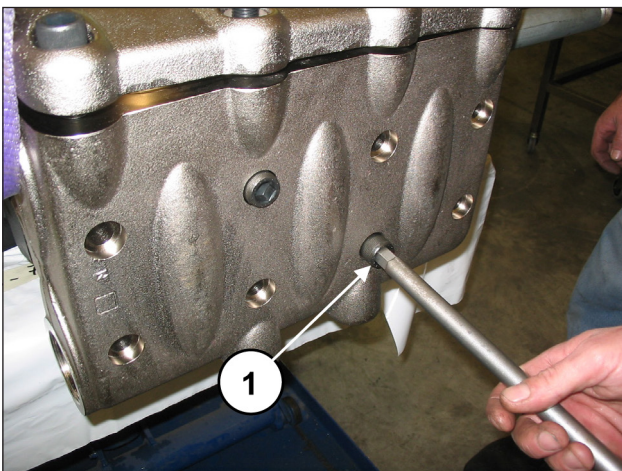

Fig. 135

Proceda com a calibragem dos parafusos M16x150 com chave dinamométrica, conforme indicado no capítulo 3, "Calibragem do aperto dos parafusos".



Aperte os oito parafusos M16x150, começando com os quatro parafusos internos, de modo transversal (ver Fig. 135), para depois prosseguir com os quatro parafusos externos, sempre apertando de modo transversal

Calibre os parafusos M16x55 da cobertura com chave dinamométrica, conforme indicado no capítulo 3, "Calibragem do aperto dos parafusos".

Aplique os dispositivos de abertura da válvula (pos. ①, Fig. 136) e solte-os mediante a chave de 30 mm (pos. ①, Fig. 137).

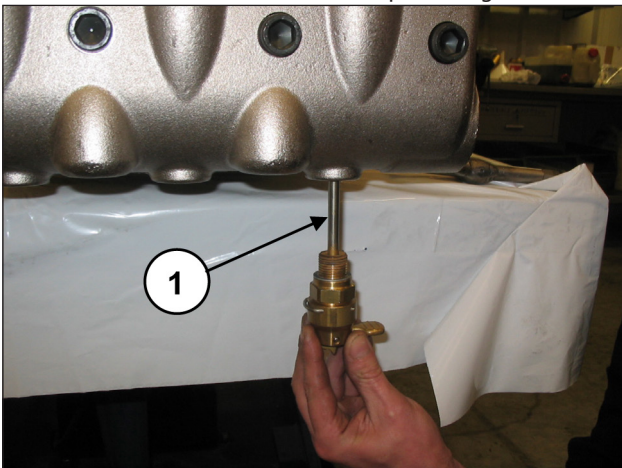

Fig. 136

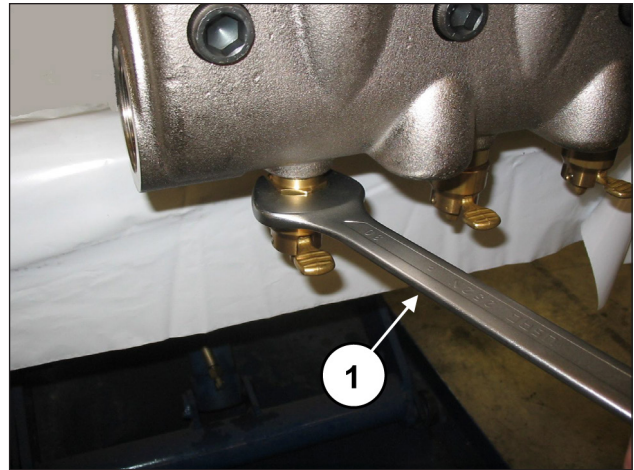

Fig. 137

2.2.3 Desmontagem do grupo do pistão - suportes - vedação

O grupo do pistão precisa de uma verificação periódica conforme indicado na tabela de manutenção preventiva do **Manual de uso e manutenção**.

As intervenções são limitadas somente ao controle visual da eventual drenagem do furo, presente na cobertura inferior. Caso se apresente anomalias/oscilações no manômetro de fluxo ou de gotejamento do furo de drenagem, será necessário proceder com o controle e a eventual substituição do pacote de vedação.

Para a extração dos grupos de pistão, opere como a seguir: Para acessar o grupo do pistão, desaperte os parafusos M16x150 e desmonte o cabeçote.



Retire o cabeçote com a máxima atenção para evitar bater os pistões.

Providencie a desmontagem dos pistões, soltando os parafusos de fixação (pos. ①, Fig. 138).

Retire o pistão do suporte de vedação e verifique se a superfície do mesmo não apresenta arranhões, sinais de desgaste ou de cavitação.

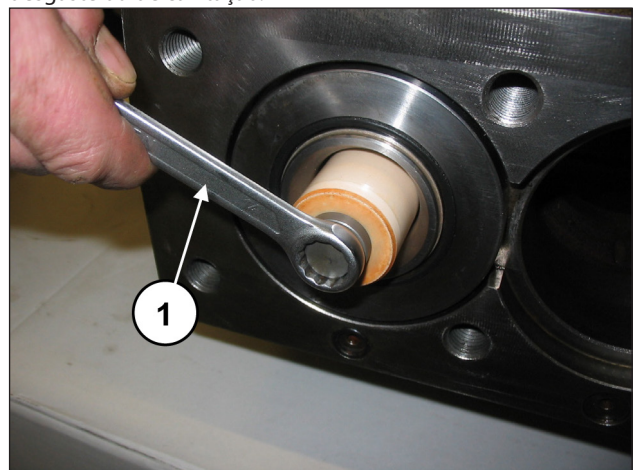

Fig. 138

Remova a cobertura de inspeção superior (pos. ①, Fig. 139) e inferior (pos. ①, Fig. 140) soltando os 4+4 parafusos de fixação.

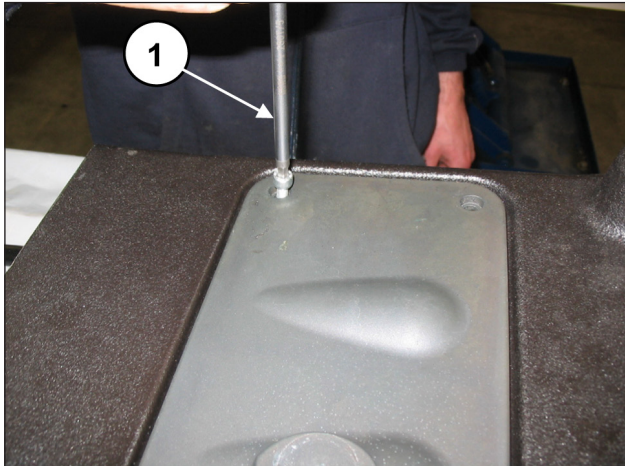

Fig. 139

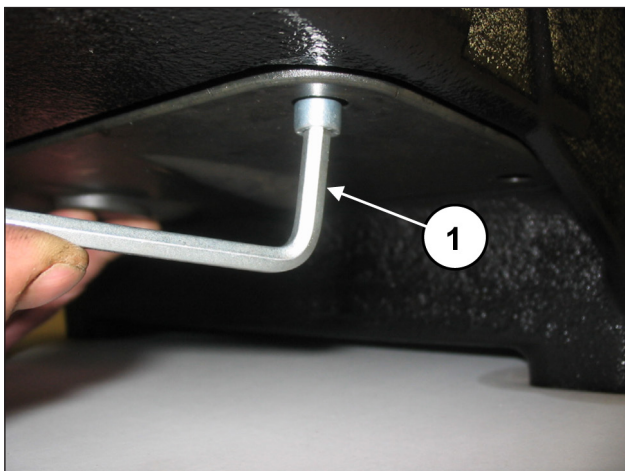

Fig. 140

Gire manualmente o eixo, de modo a trazer os três pistões na posição de ponto morto superior. Insira a ferramenta do tampão cód. 27516600 entre a guia do pistão e o pistão (pos. ①, Fig. 141).

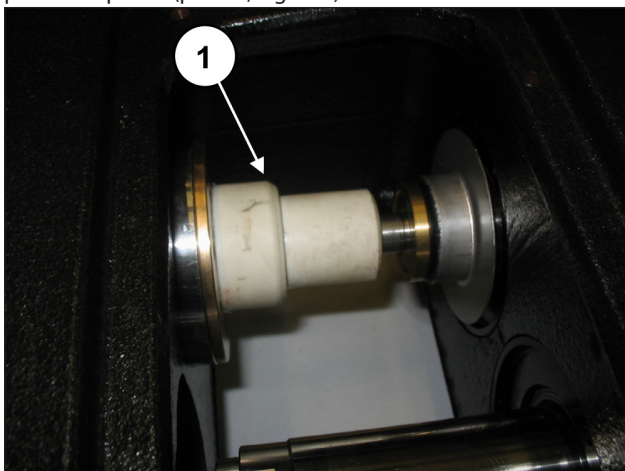

Fig. 141

Girando o eixo, avance a guia do pistão, de modo que a tampa, avançando em sua volta, podendo expelir o suporte do forro e todo o grupo do pistão (pos. ①, Fig. 142).



Fig. 142

Extraia o grupo de suporte das vedações e a ferramenta do tampão.

Retire os anéis espaçadores de proteção contra respingos da guia dos pistões (pos. ①, Fig. 143) e as proteções contra respingos (pos. ①, Fig. 144).

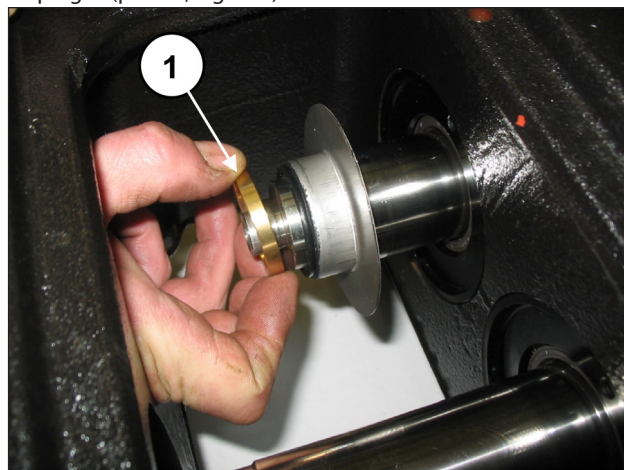

Fig. 143



Fig. 144

Separe o suporte dos forros da camisa, mediante o uso de uma chave inglesa com alças redondas Ø5, disponíveis no mercado, (pos. ①, Fig. 145), e desparafuse o suporte até a sua completa extração (pos. ①, Fig. 146).

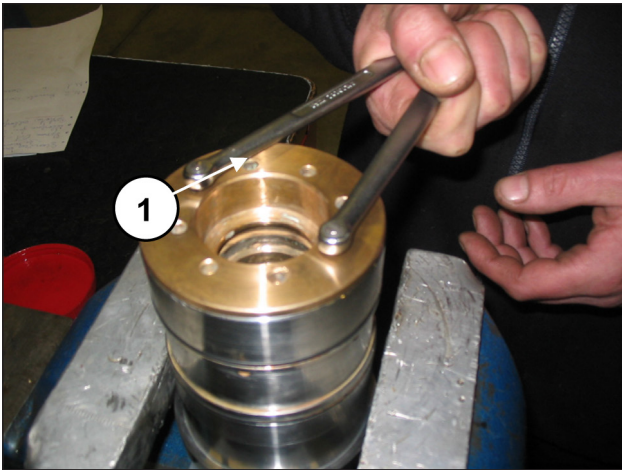

Fig. 145



Fig. 146

Extraia manualmente os anéis do cabeçote, os forros de pressão e os anéis restop (pos. ①, Fig. 147).



Fig. 147

Para remover o forro de baixa pressão, é necessário usar um medidor de espessura ou uma ferramenta que não danifique o local do suporte do forro (pos. ①, Fig. 148).

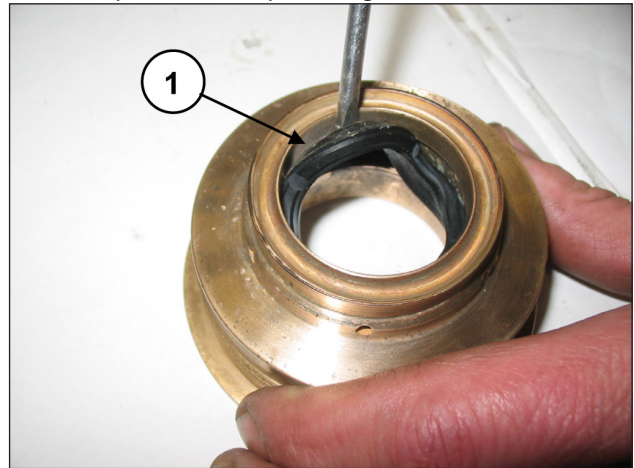

Fig. 148

2.2.4 Montagem do grupo do pistão - suportes - vedação

Proceda com a remontagem, seguindo o procedimento inverso da remontagem indicada no parág. 2.2.3.



Substitua as vedações de pressão, umedecendo as bordas com lubrificante de silicone (sem borrifar), prestando muita atenção para não danificá-las durante a inserção na camisa.



A cada desmontagem, os forros de pressão devem ser sempre substituídas juntas com todos os anéis circulares.

Insira os forros de baixa pressão no suporte do forro (pos. ①, Fig. 149) prestando atenção para o sentido da montagem, que fornece a borda de vedação para a frente (na direção do cabeçote).

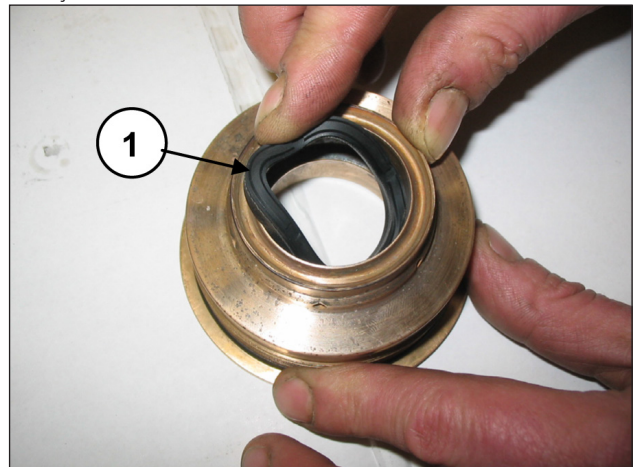

Fig. 149

Monte o anel do cabeçote (pos. ①, Fig. 150), o forro de alta pressão (pos. ①, Fig. 151) e o anel restop (pos. ①, Fig. 152).

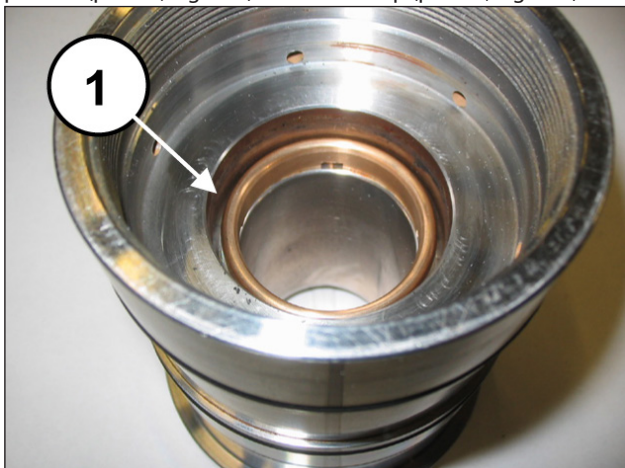

Fig. 150

Insira o anel circular do suporte do forro no local adequado (pos. ①, Fig. 153).

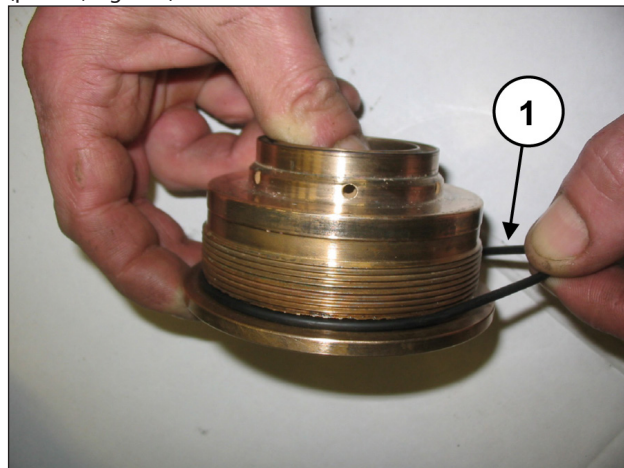

Fig. 153

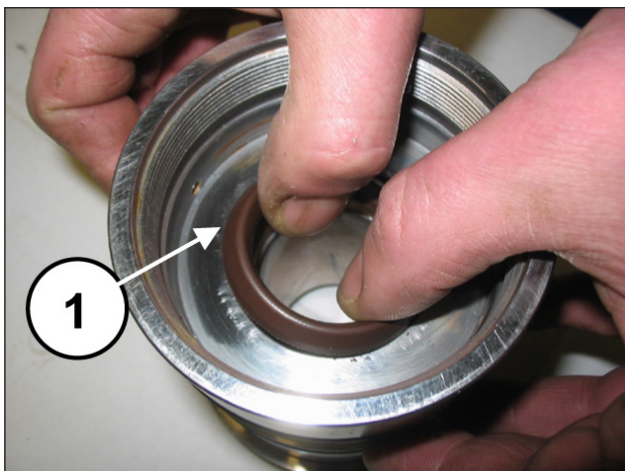

Fig. 151

Aperte o suporte dos forros na camisa (pos. ①, Fig. 154), e aperte através de uma chave inglesa com alças redondas Ø5, disponíveis no mercado, (pos. ①, Fig. 155), até trazer o suporte da camisa na passagem.



Fig. 154



Fig. 152

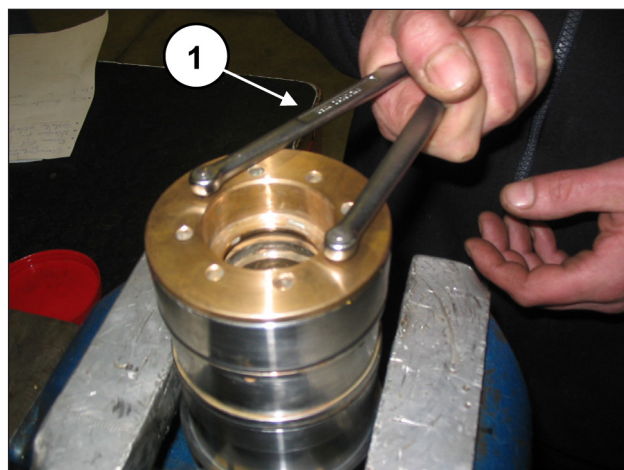

Fig. 155

Insira a arruela Ø10x18x0.9 no parafuso de fixação do pistão (pos. ①, Fig. 156).

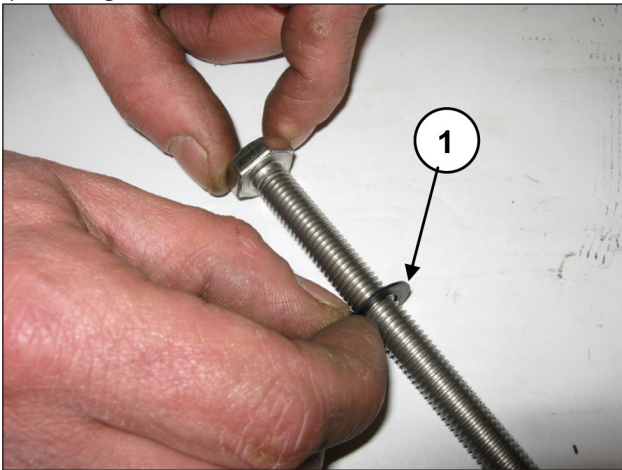

Fig. 156

Monte os pistões nas respectivas guias (pos. ①, Fig. 157) e fixe-as, conforme a pos. ①, Fig. 158.

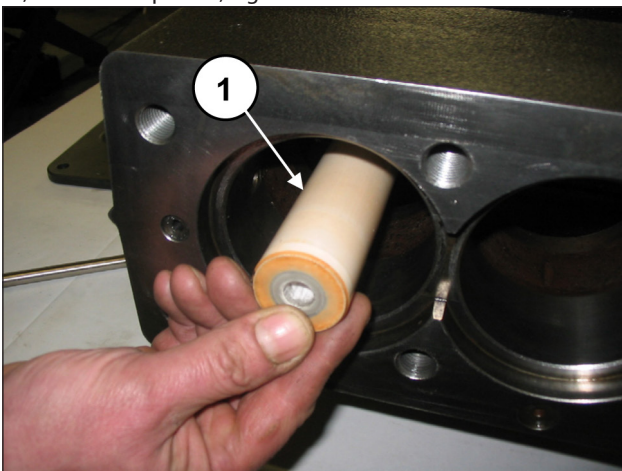

Fig. 157

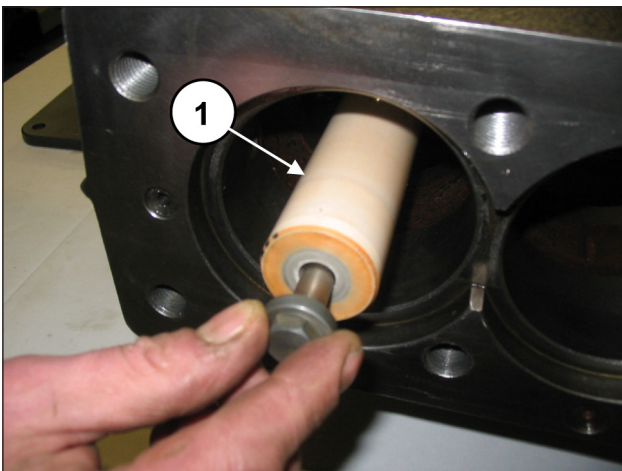

Fig. 158

Calibre os parafusos com chave dinamométrica, conforme indicado no capítulo 3.

Insira o bloco camisa-suporte da passagem (completo por dois anéis circulares adequados), anteriormente montado até a passagem (pos. ①, Fig. 159).

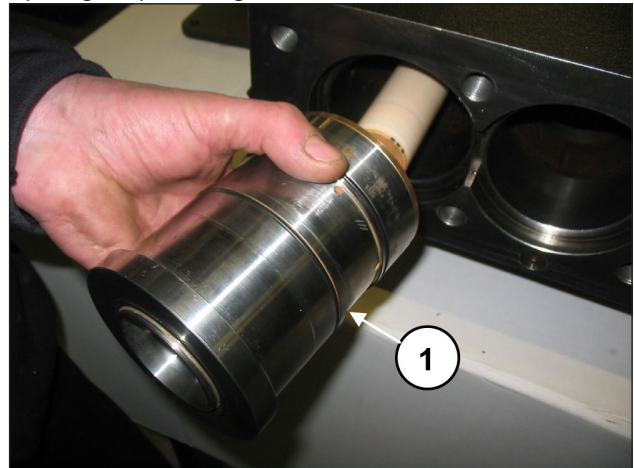

Fig. 159

Certifique-se de que o bloco da camisa - suporte chegue a se posicionar no fundo do local (pos. ①, Fig. 160).

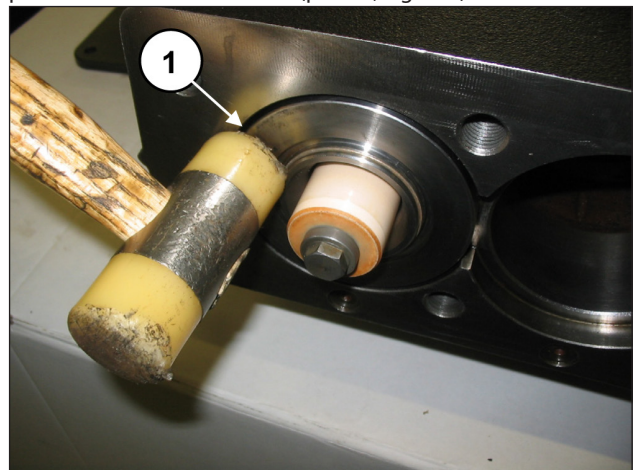

Fig. 160

Monte o anel circular frontal da camisa (pos. ①, Fig. 161) e o anel circular do furo de recirculação (pos. ①, Fig. 162).

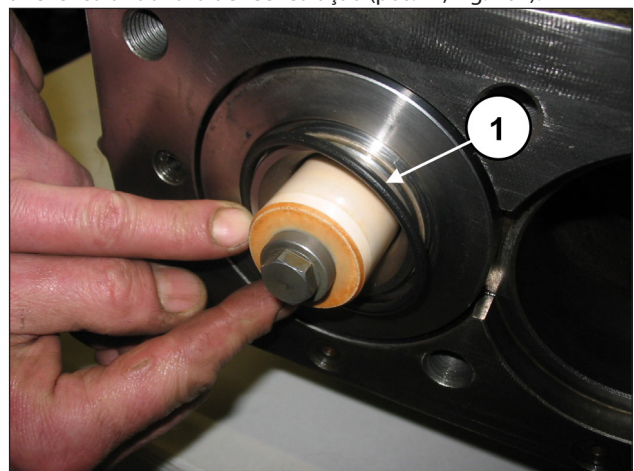

Fig. 161

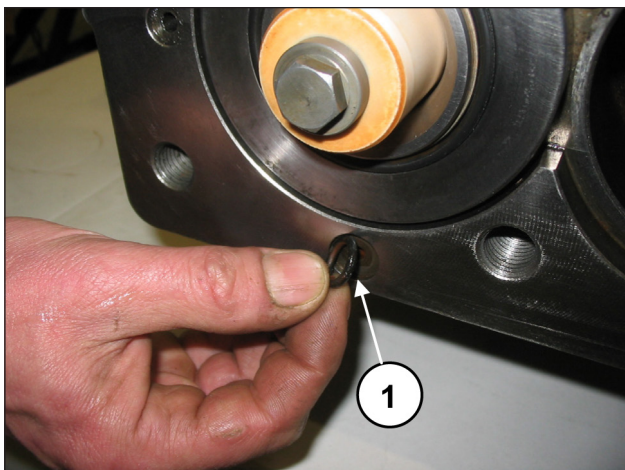

Fig. 162

Nas coberturas de inspeção, insira o anel circular (pos. ①, Fig. 163) e monte as coberturas mediante o uso de 4+4 parafusos M6x14 (pos. ①, Fig. 164).

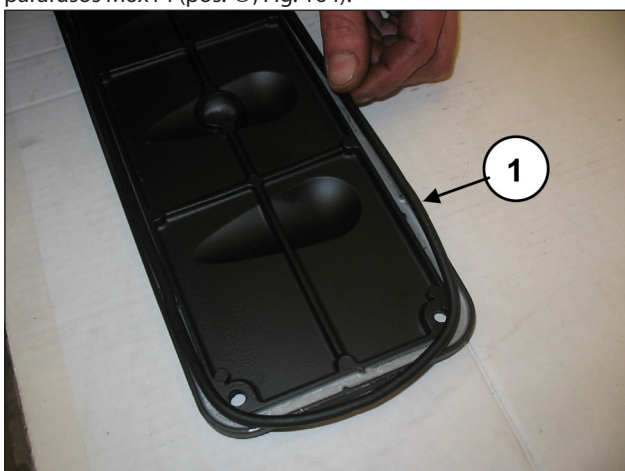

Fig. 163

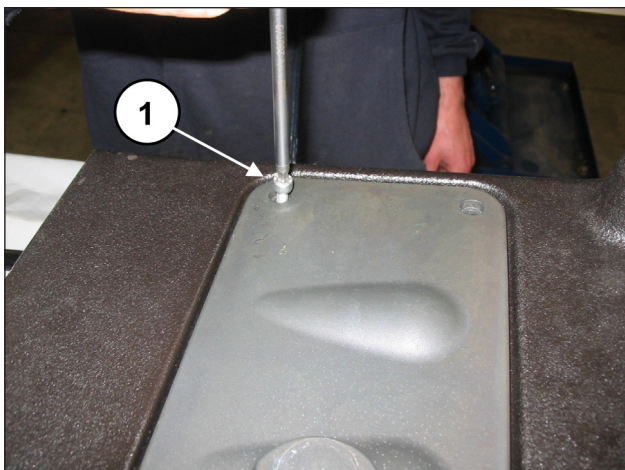

Fig. 164

Calibre os parafusos com chave dinamométrica, conforme indicado no capítulo 3.

2.2.5 Recuperação dos cabeçotes

Se o cabeçote apresentar no interior das câmaras dos pistões sinais evidentes de cavitação, devido a uma alimentação incorreta da bomba, é possível recuperar o cabeçote danificado evitando a sua substituição.

Para a recuperação do cabeçote, execute os trabalhos indicados na Fig. 165 para LK36-40-45 e na Fig. 166 para LK50-55-60:

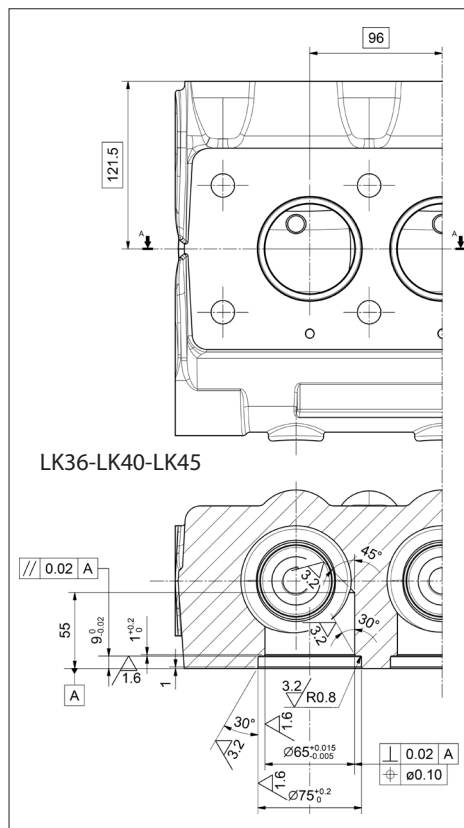

Fig. 165

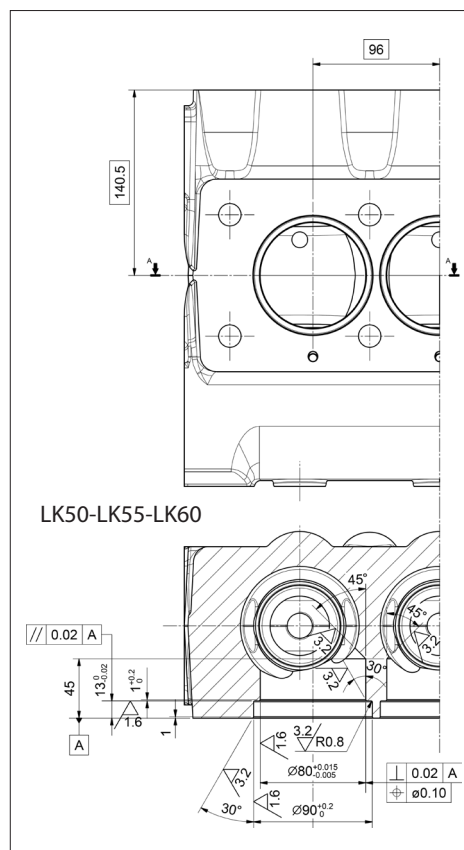

Fig. 166

O cabeçote trabalhado deve ser montado, ao martelar as buchas (pos. ①) completas com anéis anti-extrusão (pos. ②) e anel circular (pos. ③), conforme apresentado na Fig. 167 para LK36-40-45 e na Fig. 168 para LK50-55-60:

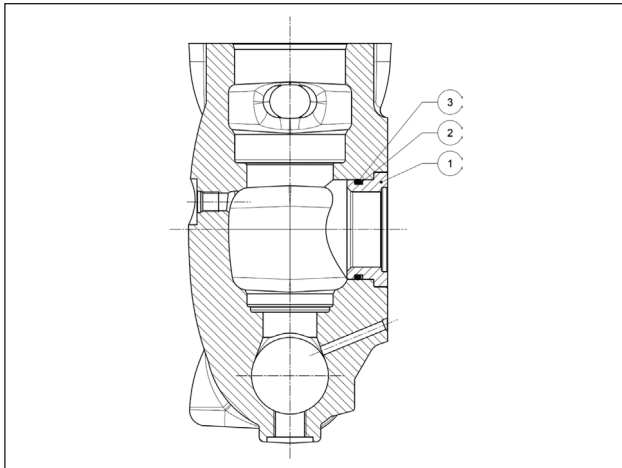

Fig. 167

- n. 1 - Bucha LK36-40-45 - cód. 78216756 - quantidade 3
- n. 2 - Anel anti-extrusão - cód. 90526880 - quantidade 6
- n. 3 - anel circular - cód. 90410200 - quantidade 6

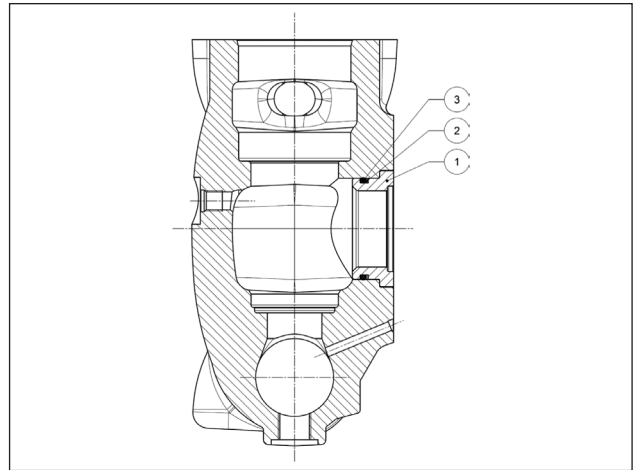

Fig. 168

- n. 1 - Bucha LK50-55-60 - cód. 78216656 - quantidade 3
- n. 2 - Anel anti-extrusão - cód. 90528500 - quantidade 6
- n. 3 - anel circular - cód. 90412900 - quantidade 6

3 CALIBRAGEM DO APERTO DOS PARAFUSOS

O aperto dos parafusos é para ser executado exclusivamente com chave dinamométrica.

Descrição	Posição de explosão	Torque de aperto Nm
Parafuso M8x20 da cobertura do carter	54	25
Tampa G1/2x13 do carter	78	40
Parafuso M8x30 da cobertura do rolamento PTO	95	25
Parafuso M8x20 da cobertura da extremidade do eixo	54	25
Parafuso M10x30 da cobertura do porta-rolamento	69	45
Parafuso M6x14 das coberturas superior e inferior	82	10
Parafuso M8x20 da cobertura do rolamento	54	25
Parafuso M12x1.25x87 de aperto da haste	52	75*
Parafuso M6x20 da guia do pistão	49	10
Parafuso M12x25 da flange de bloqueio da bússola	63	68.5
Parafuso M10x160 de fixação do pistão	27	40
Parafuso M16x55 da cobertura da válvula	26	333
Tampa G1/4"x13 do cabeçote	13	40
Parafuso M16x150 do cabeçote	25	333**
Dispositivo de abertura da válvula	2	40

* Alance o torque de aperto, apertando os parafusos simultaneamente.

** aperte os parafusos, começando pelos quatro parafusos internos, de modo transversal (ver Fig. 135), para depois prosseguir com os quatro parafusos externos, sempre apertando de modo transversal.

4 FERRAMENTAS PARA A REPARAÇÃO

A manutenção da bomba pode ser realizada através de ferramentas simples para a desmontagem e remontagem dos componentes. As seguintes ferramentas estão disponíveis:

Para a montagem:

Anel de vedação radial da guia do pistão	cód. 27910900
Anel de vedação radial do eixo PTO	cód. 27539500
	cód. 27548200
Anel circular do local da válvula de fluxo LK36-LK40-LK45	cód. 27516000
Anel circular do local da válvula de fluxo LK50-LK55-LK60	cód. 27516100

Para a desmontagem:

Local da válvula de aspiração LK36-LK40-LK45	cód. 27516200
local da válvula de aspiração LK50-LK55-LK60	cód. 27516300
Local da válvula de fluxo	cód. 27516400
Bloco da camisa + suporte das vedações	cód. 27516600
Eixo (bloqueio da haste)	cód. 27566200

5 VERSÕES ESPECIAIS

A seguir estão relacionadas as indicações relativas à reparação das versões especiais. Onde não estiver especificado de forma diferente, consulte as informações relacionadas anteriormente para a bomba LK versão padrão.

- Bomba LKN: para a reparação estão sujeiras as indicações relativas à bomba LK padrão.

6 SUBSTITUIÇÃO DA BUCHA DO PÉ DA HASTE

Martele a bucha a frio e os trabalhos seguintes, prestando atenção às dimensões e a tolerância da Fig. 169 abaixo.

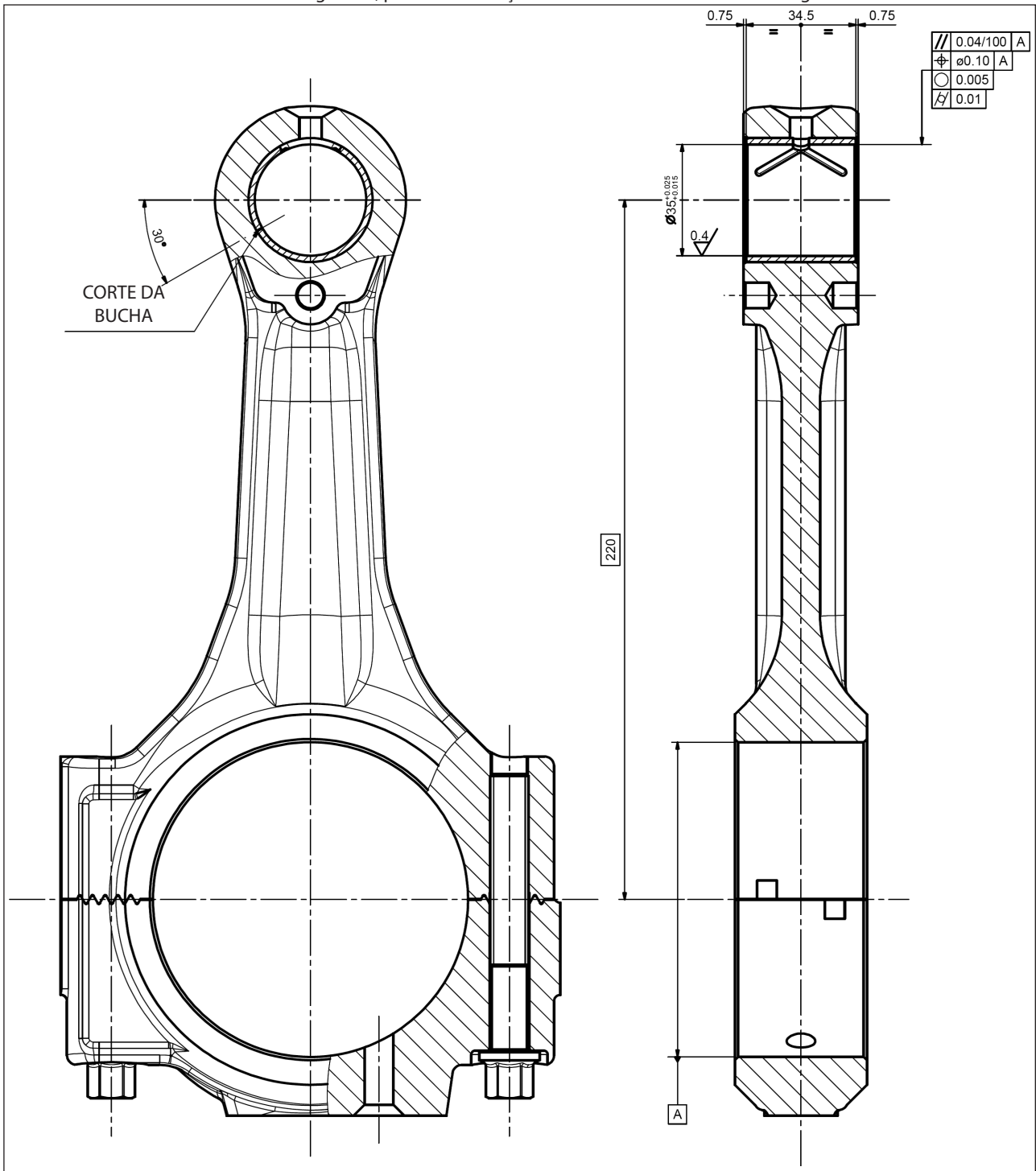
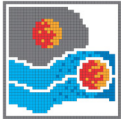

Fig. 169



Pratissoli

Copyright di queste istruzioni operative è di proprietà di Interpump Group.

Le istruzioni contengono descrizioni tecniche ed illustrazioni che non possono essere elettronicamente copiate e neppure riprodotte interamente od in parte né passate a terzi in qualsiasi forma e comunque senza l'autorizzazione scritta dalla proprietà. I trasgressori saranno perseguiti a norma di legge con azioni appropriate.

Copyright of these operating instructions is property of Interpump Group.

The instructions contain technical descriptions and illustrations which may not be entirely or in part copied or reproduced electronically or passed to third parties in any form and in any case without written permission from the owner. Violators will be prosecuted according to law with appropriate legal action.

D'après les lois de Copyright, ces instructions d'utilisation appartiennent à Interpump Group.

Les instructions contiennent des descriptions techniques et des illustrations qui ne peuvent être ni copiées ni reproduites par procédé électronique, dans leur intégralité ou en partie, ni confiées à des tiers sous quelque forme que ce soit, en l'absence de l'autorisation écrite du propriétaire. Les transgresseurs seront poursuivis et punis par la loi.

Copyright-Inhaber dieser Betriebsanleitung ist Interpump Group.

Die Anleitung enthält technische Beschreibungen und Abbildungen, die nur mit vorheriger schriftlicher Genehmigung des Copyright-Inhabers elektronisch kopiert, zur Gänze oder teilweise reproduziert oder in jeglicher Form an Dritte weitergegeben werden dürfen. Bei Verstößen drohen Rechtsfolgen.

El copyright de estas instrucciones operativas es propiedad de Interpump Group.

Las instrucciones contienen descripciones técnicas e ilustraciones que no pueden ser copiadas electrónicamente ni reproducidas de modo parcial o total, así como pasadas a terceras partes de cualquier forma y sin la autorización por escrito de la propiedad. Los infractores serán procesados de acuerdo a la ley con las medidas adecuadas.

Os direitos autorais destas instruções operacionais são de propriedade da Interpump Group.

As instruções contêm descrições técnicas e ilustrações que não podem ser eletronicamente copiadas ou reproduzidas inteiramente ou em parte, nem repassar a terceiros de qualquer forma sem autorização por escrito da proprietária. Os infratores serão processados de acordo com a lei, com as ações apropriadas.

I dati contenuti nel presente documento possono subire variazioni senza preavviso.

The data contained in this document may change without notice.

Les données contenues dans le présent document peuvent subir des variations sans préavis.

Änderungen an den in vorliegendem Dokument enthaltenen Daten ohne Vorankündigung vorbehalten.

Los datos contenidos en el presente documento pueden sufrir variaciones sin previo aviso.

Os dados contidos no presente documento podem estar sujeitos a alterações, sem aviso prévio.



Pratissoli

A brand of INTERPUMP GROUP S.p.A.

42049 S. Ilario—Reggio Emilia (Italy)

Tel. +39-0522-904311

Fax +39-0522-904444

E-mail : info@pratissolipompe.com

<http://www.pratissolipompe.com>



INTERPUMP GROUP

**AZIENDA CON SISTEMA
DI GESTIONE QUALITÀ
CERTIFICATO DA DNV
= ISO 9001 =**

Cod. 78980303/3 - Cod.IE 28600000051/3 - 12/09/2013 - 2076